



Power transmission for your success



Operating Instructions

Gearboxes ZM/I and
geared motors SZM/I, ZMD/I



D

PCA 1, 2, 3
Subsidiary
MÄDLER GmbH
Brookstieg 16
D-22145 Stapelfeld
Tel. +49 40-60 04 75 10
hamburg@maedler.de
www.maedler.de

D

PCA 0, 4, 5
Subsidiary
MÄDLER GmbH
Bublitzer Str. 21
D-40599 Düsseldorf
Tel. +49 211-97 47 10
duesseldorf@maedler.de
www.maedler.de

D

PCA 6, 7, 8, 9
Headquarter
MÄDLER GmbH
Tränkestr. 6-8
D-70597 Stuttgart
Tel. +49 711-7 20 95 0
stuttgart@maedler.de
www.maedler.de

A

MÄDLER
Österreich GmbH
Schottenfeldgasse 14/3
A-1070 Wien
Tel. +43 1398 1398-00
info@maedler.at
www.maedler.at

CH

MÄDLER
NORM-ANTRIEB AG
Haldenstr. 14
CH-8245 Feuerthalen
Tel. +41 52 647 40 40
info@maedler.ch
www.maedler.ch

Condition upon delivery

All gearboxes and worm gear units are put through a final inspection before shipment and checked according to the specification in the order.

The units are delivered coated with a two-component epoxy resin base primer in RAL 9010 (white) and filled with oil, if no other instructions are given.

The operating and maintenance instructions, the vent filter and the coupling (only on types M and DM without motor) are delivered loose in an accompanying package. The gearsets are given a corrosion protective coating before packaging.

During the warranty period, units may only be opened with our express permission, otherwise all terms of the warranty become invalid.

Storage

If the gear unit or gear motor is initially to be placed in temporary storage, the storage area should be dry and without extreme fluctuations in temperature, in order to inhibit condensation and consequential corrosion.

Assembly

When assembling the gear units, always be certain that the provided oil fittings, such as vent, gauges and drain are readily accessible. Also be certain that there is enough fresh air for cooling.

The unit must be assembled in the order mounting position, for only then can proper lubrication and ventilation be guaranteed during operation.

Installation

Drives with shaft end

The gear unit should be placed together with the machine to be driven on a solid base. Flanged units can be mounted directly on the machine to be driven. In the interest of safety and low-noise operation, the shafts must be carefully aligned. Housing and shaft must be torsion-free. To account for small installation tolerances, we recommend the use of flexible couplings.

Drives with hollow shaft

Hollow shaft units can be placed directly on the shaft of the machine to be driven. Axial fastening proceeds correctly by using an end washer and a screw. Be certain that the mounting surface lies square to the axis of the machine to be driven. Otherwise the unit bearing will be overloaded and could break down prematurely. The corresponding reactive force to the output torque can be compensated for by a torque bracket. In order to avoid additional bending stress, always attach the torque bracket to the machine side of the gear unit.

Caution: Direct mounting of the gear unit to the base plate while mounting the machine shaft near the gear unit should be absolutely avoided. For shrink-on disks, never tighten the tensioning screws before the shaft has been installed, otherwise deformation of the hollow shaft is possible.

Fitting of couplings, etc

When fitting couplings, sprockets, gear wheels or pulleys, etc. this should be done when warm or with the help of the thread centering device and a screw. Ensure that there is axial support.

Apply rolling bearing grease to the toothing of the motor coupling before mounting.

Caution: Never hammer supplementary parts onto the shafts in order to avoid damaging tooth profiles, rolling bearing and locking rings.

Safety precautions

Rotating parts must be protected by the user from unintentional contact according to the requirements of the law.

Electrical connection

Electrical connection and maintenance work on electric drives may only be performed by electrical technicians with attention to rules for accident prevention and installation. Unintentional switching on the circuit while working on operational live parts should be avoided by means of appropriate measures.

Available supply voltage and frequency must agree with the information given on the maker's plate of the gear motors. Circuit diagrams, for connection of a motor as well as for the brake, can be found in the terminal box.

Lubrication

All worm gear units and variants as well as gear motors are filled with synthetic lubricant at the factory, unless otherwise indicated in the confirmation of order. If a gear unit is requested to be delivered dry, it should be filled with an oil quality according to the maker's plate. When using mineral oils, reduced performance should be taken into account. Please ask for advice about this.

The recommended level of oil is reached when oil drips out of the oil level screw (size 100 to 315). For lubrication amounts refer to lubrication table.

Putting into operation

Before putting the drive into operation, make certain all the above-mentioned points have been considered. On all gear units that have been filled with lubricant at the factory, first replace the seal plug with the accompanying vent filter, which should be free of foreign matter. A stopped-up vent causes internal pressure to increase and can possibly lead to leaks. On gear units that have been delivered dry, the vent filter is already installed.

Unit size 040 is delivered for all mounting positions in an enclosed design without a vent filter.

Every unit and every worm gearset should at first be run at no load for some time and then for several hours at approx. 50% of load. If it is impossible to run at part-load, the unit should be repeatedly turned off every time the oil temperature reaches 85-90 °C.

A good warm-up is decisive for output capability and the long life of the unit. The expected performance can only be achieved by units or worm gear sets that have been allowed to warm up well.

Maintenance

Since the efficiency and lifetime, especially of worm gear units, is greatly affected by the quality of oil used, we recommend only using the oil qualities listed on the maker's plate or in the lubricant tables.

Our units designed for synthetic lubricant must never be filled with mineral oil in an oil change. This also applies vice versa.

Synthetic and mineral lubricants must not be mixed. Not all synthetic lubricants can be mixed with one another. When filling be very aware of cleanliness – consider using a filter fine sieve.

The correct level of oil is reached when oil drips from the oil level screw (size 100 to 315). For the immersion depth of worm gear sets (oil levels), see catalogue page 10.

For lubricant amounts see lubricant table.

Synthetic oil

Gear units which are filled with synthetic oil are maintenance-free under normal operation conditions. After longer periods of time, the unit should be inspected for leakage. Should it be necessary to refill, a synthetic lubricants as suggested on the maker's plate should be used. Different oil viscosity's are needed according to rotation speed.

Change the oil according to the maker's plate after approx. 15,000 service hours, or after 5 years at the latest.

The synthetic oils listed in the lubricant table afford high output, reduced friction, have a very good viscosity-temperature ratio and offer excellent protection against wear. They are also extremely resistant to ageing.

Synthetic gear unit oils can be used in a temperature range from -30°C to $+140^{\circ}\text{C}$. At higher temperatures, special seals may be needed. The choice of oil quality is relative to worm shaft speed.

Speed of worm shaft (min^{-1})		
above	to	oil quality
1500	3000	PG 220
300	1500	PG 460
	300	PG 680

Mineral oil

Gear units with mineral lubrication should have their first oil change after approx. 150 hours. After draining the used oil while still warm, rinse with a clean thin oil of the same label. Further oil changes after refilling should be done after 3,000 to 4,000 service hours, or after a maximum of 18 months.

The mineral oils listed in the lubrication table contain additives to increase the aging resistance, corrosion protection as well as improvement of performance in the mixed friction area, following the minimum requirements of DIN51517/3. The following grades fulfil the CLPF designation according to DIN 51502:

ARAL BMB
KLÜBER Unimoly
TRIBOL Molub-Alloy

Mineral oils are usable in a temperature range of -10°C to $+90^{\circ}\text{C}$. The choice of oil qualities is relative to worm shaft speed.

Speed of the worm shaft (min^{-1})		
above	to	oil quality
2000	3000	<i>CLP 220</i>
1000	2000	<i>CLP 320</i>
300	1000	CLP 460
	300	CLP 680

Higher ambient temperature are taken into account by using the operation temperature factor f_t . Gear unit types D and DM have separate lubrication chambers; different oil viscosity's can be used above until size 100.

For lubricating toothed couplings and rolling bearings, lithium-soap grease is recommended.

Mixing different soaps is not permissible.

Lubricant amounts

in liters (dm³)

Typ ZM/I and ZMD/I:

Size	Mounting position			
	1	2	3+4	5+6
40	0,2	0,25	0,2	0,2
50	0,3	0,6	0,6	0,45
63	0,6	1,1	1,1	0,8
80	1,0	2,1	1,6	1,6
100	1,5	4,8	3,35	3,0
125	2,5	6,5	4,5	4,5
160	4,25	9,8	8,4	9,5

Typ SZM/I:

Size	Mounting position			
	1	2+3	4	5+6
50	0,5	1,0	1,0	0,8
63	0,8	1,5	1,8	1,2
80	1,3	2,5	3,2	2,0
100	2,5	5,5	6,9	3,75
125	4,3	8,2	8,9	5,5

The listed lubricant levels are given only for reasons of planning. The correct oil level must be verified by observation

Worm gearset oil level

The following table shows the recommended oil levels for immersion lubrication. Be certain that the bearings above the oil level has sufficient lubrication.
Oil level in the unit during immersion lubrication

Mounting position

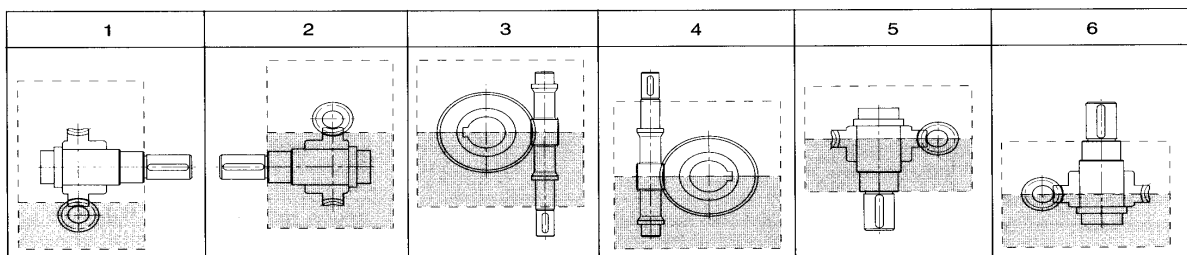









Required minimum oil amounts

To prevent premature ageing due to dirt and heating of the unit oil, amounts should not fall below the following oil levels during immersion lubrication

Size	Minimum oil amount in unit [dm ³]	Size	Minimum oil amount in unit [dm ³]
40	0,2	100	1,5
50	0,3	125	2,5
63	0,5	160	4,25
80	0,9	200	7,6

Lubricants

Schmierstoff Lubricant Lubrifiant	Öqualität gem. Typenschild Viskosität [mm ² /s] (cSt) bei 40° Oil quality as per maker's plate Viscosity (mm ² /s)(cSt) at 40° Qualité d'huile selon plaque signalétique Viscosité [mm ² /s] (cSt) à 40 °								
Synthetische Öle (Polyglycole) Synthetic oils (polyglycols) Huiles synthétiques (polyglycols)	PG 220	Degol GS 220	BP Energol SG-XP 220	Polydea PGLP 220	Glycolube 220	Syntheso HT 220	Mobil Glygoyl 30	Tivela Oil WB	TRIBOL 800/220
	PG 460	Degol GS 460	BP Energol SG-XP 460	Polydea PGLP 460	Glycolube 460	Syntheso HT 460	Mobil Glygoyl 80	Tivela Oil SD	TRIBOL 800/460
	PG 680	Degol GS 680	-	-	-	Syntheso HT 680	-	-	TRIBOL 800/680
<p>Eine Mischung mit mineralischen Schmierstoffen ist nicht zulässig. Mixing mineral lubricants is not permissible Il est interdit de mélanger un lubrifiant synthétique et un lubrifiant minéral.</p>									
Mineralöle Mineral oils Huiles minérales	CLP 68	BG 68 BMB 68	BP Energol GR-XP 68	Falcon CLP 68	SPARTAN EP 68	Klüberoil GEM 1 - 68	Mobilgear 626	Shell Omala Oel 68	TRIBOL 1100/68 MOLUB- ALLOY 804
	CLP 100	BG 100 BMB 100	BP Energol GR-XP 100	Falcon CLP 100	SPARTAN EP 100	Klüberoil GEM 1 - 100	Mobilgear 627	Shell Omala Oel 100	TRIBOL 1100/100 MOLUB- ALLOY 80
	CLP 220	BG 220 BMB 220	BP Energol GR-XP 220	Falcon CLP 220	SPARTAN EP 220	Klüberoil GEM 1 - 220	Mobilgear 630	Shell Omala Oel 220	TRIBOL 1100/220 MOLUB- ALLOY 90
	CLP 320	BG 320 BMB 320	BP Energol GR-XP 320	Falcon CLP 320	SPARTAN EP 320	Klüberoil GEM 1 - 320	Mobilgear 632	Shell Omala Oel 320	TRIBOL 1100/320 MOLUB- ALLOY 690
	CLP 460	BG 460 BMB 460	BP Energol GR-XP 460	Falcon CLP 460	SPARTAN EP 460	Klüberoil GEM 1 - 460	Mobilgear 634	Shell Omala Oel 460	TRIBOL 1100/460 MOLUB- ALLOY 140
	CLP 680	BG 680 BMB 680	BP Energol GR-XP 680	Falcon CLP 680	SPARTAN EP 680	Klüberoil GEM 1 - 680	Mobilgear 636	Shell Omala Oel 680	TRIBOL 1100/680 MOLUB- ALLOY 190
Schmierfette (Wälzlager + Zahnkupplungen) Lubricating greases (rolling bearings + toothed couplings) Graisse de lubrification (roulements + accouple- ments dentés)		Aralup HLP 2	BP Energrease LS-EP 2	-	Beacon EP 2	Centoplex 2	Mobilux EP 2	Shell AlvaniaEP Fett 2	TRIBOL 3030

Lubricants for the food processing and pharmaceutical industry authorized by the USDA (USDA-H11):

Mobil DTE FM 220 / Mobil DTE FM 460 / Mobil DTE FM 680.

Electric motors

Brake motors

Brake motors are equipped with springloaded brakes (mounted between motor endshield and the fan blade) underneath the fan cowl.

When starting the motor the brake is supplied with DC voltage over an appropriate rectifier. The springloaded brake is a closed circuit operated electro-magnetic brake, comprised of a magnet (1), an armature disk (2) and a brake rotor (3). It is fastened with screws (4) to the motor endshield (5), and enclosed in a fan cowl (6). The motor endshield serves as a brake surface.

In a dead condition, the compression springs (7) press the armature disk (2) against the brake rotor (3) and the brake rotor against the motor endshiled (5). Braking torque is produced on both surfaces by friction lock. When starting the motor, the magnet coil is excited and the power of the magnet (1) pulls the armature disk (2) against the energy of the spring. The brake rotor (3) is released. Braking torque can be reduce by a maximum of 40% by means of the adjustment ring (8).

[1] Magnet [2] Armature disk [3] Brake rotor [4] Screws [5] Motor endshield [6] Fan cowl [7] Compression spring [8] Adjustment ring [9] Manual release knob

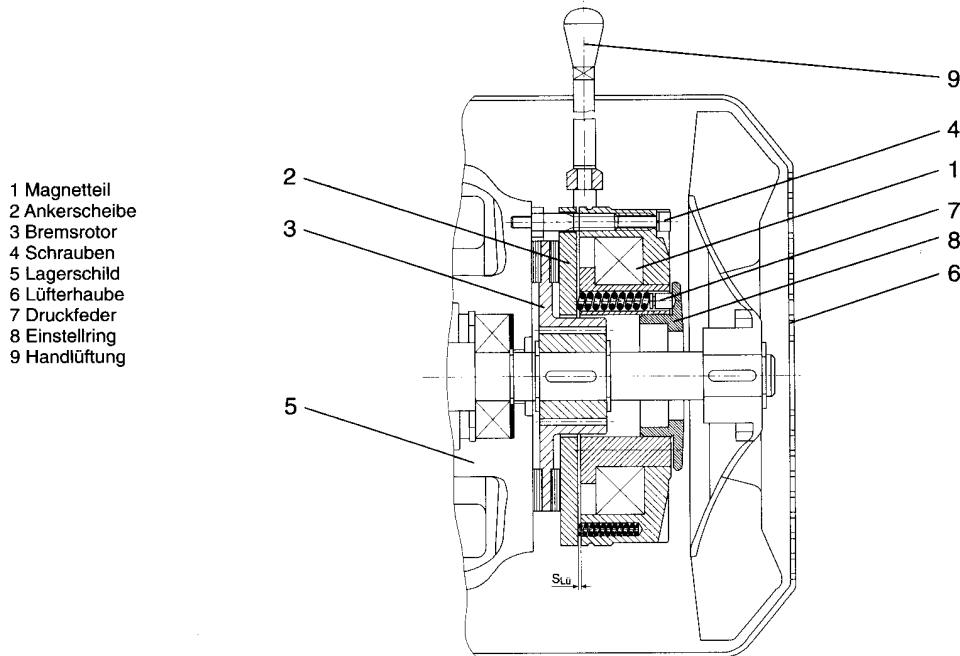

Motor size	unit	Motor extension [mm]	Brake size								
			06	08	10	12	14	16	18	20	25
			Brake torque [Nm]								
			4	8	16	32	60	80	150	240	360
63		60	X	X							
71		68	X	X	X						
80		67	X	X	X						
90		75		X	X	X					
100		90		X	X	X	X				
112		95			X	X	X	X			
132		122			X	X	X	X	X		
160		130				X	X	X	X	X	
180		145					X	X	X	X	X
200		175							X	X	X
225		200								X	X
250		235								X	X

Braking voltage

The braking voltage is normally designed so that it is suited to the motordelta voltage (i.e. 230/400 V D/Y = brake coil control 230 V a/c.) For motors which use star-/delta starting and on pole-changing motors, the braking voltage is designed according to the phase voltage of the circuit

$$\text{phase} = \frac{\text{rated voltage}}{\sqrt{3}}$$

Motor voltage	AC Voltage input to the rectifier	Rated coil voltage	Rectifier
42/72 V	42	36 V	full wave
127/220 V	127	115 V	full wave
220/380 V	220	205 V	full wave
		103 V	half wave
230/400 V	230	205 V	full wave
		103 V	half wave
240/415 V	240	205 V	full wave
		103 V	half wave
255/440 V	255	215 V	full wave
		115 V	half wave
290/500 V	290 V~	127 V	half wave
380 V Δ	380 V~	180 V	half wave
400 V Δ	400 V~	180 V	half wave
415 V Δ	415 V~	180 V	half wave
420 V Δ	420 V~	180 V	half wave
440 V Δ	440 V~	205 V	half wave
460 V Δ	460 V~	205 V	half wave
480 V Δ	480 V~	215 V	half wave
500 V Δ	500 V~	215 V	half wave

Standard voltage 24 V, 103 V, 180 V, 205 V
maximum possible coil voltage 250 V DC

Air gap

The air gap $S_{L\ddot{U}}$ should be checked from time to time. Wear on the rotor, stressed from friction on the surfaces, depends upon the amounts to be braked, the speed and switching frequency.

Having reached $S_{L\ddot{U} \text{ max.}}$ (see table), reset the air gap to $S_{L\ddot{U}}$

Brake type	06	08	10	12	14	16	18	20	25
Brake torque [Nm]	4	8	16	32	60	80	150	240	360
Coil power at 20°C [W]	20	25	30	40	50	55	85	100	110
$S_{L\ddot{U}}$	0,2	0,2	0,2	0,3	0,3	0,3	0,4	0,4	0,5
$S_{L\ddot{U} \text{ max.}}$	0,5	0,5	0,5	0,7	0,8	1,0	1,0	1,2	1,4

Special sealing against dust, dirt and moisture

For extreme operating conditions under the effects of dust, airborne fibres, dirt and water, as well as intermittent operation in connection with frost, brakes are available in an enclosed design. (Supplementary charge quoted upon request.)

Anschlußpläne

Drehstrommotoren

Wiring sketches

Three-phase motors

Schéma de montage

Moteurs triphasés

Klemmbrett
terminal plate
tableau de commande

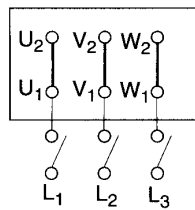

Schaltung ~230 V Δ (Dreieckschaltung)
operating ~230 V Δ (delta operating)
Raccordement ~230 V Δ (montage en triangle)

Klemmbrett
terminal plate
tableau de commande

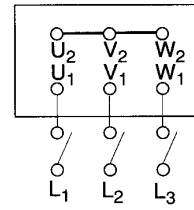

Schaltung ~400 V Y (Sternschaltung)
operating ~400 V Y (star operating)
Raccordement ~400 V Y (montage en étoile)

Bremsmotoren

Brake motors

Moto - freins

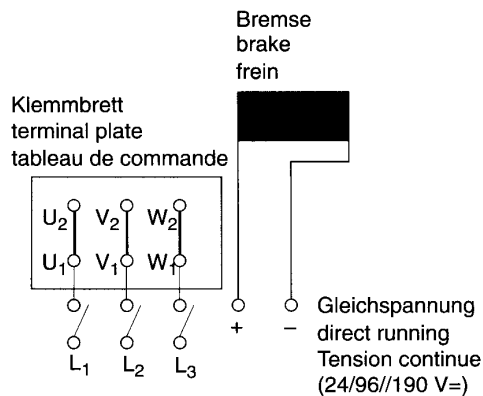

Schaltung ~230 V Δ (Dreieckschaltung)
operating ~230 V Δ (delta operating)
Raccordement ~230 V Δ (montage en triangle)

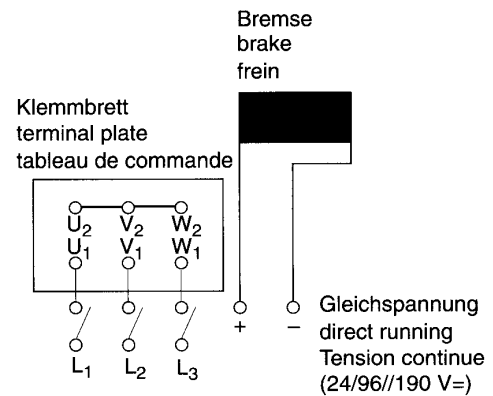

Schaltung ~400 V Y (Sternschaltung)
operating ~400 V Y (star operating)
Raccordement ~400 V Y (montage en étoile)

Anschlußpläne

Wiring sketches

Schéma de montages

Bremsmotoren

Brake motors

Moto - freins

**wechselstromseitig geschaltet
(verzögertes Bremsen)**

**a. c. - switched
(delayed braking)**

**coupe côté courant alternatif
(freinage normal)**

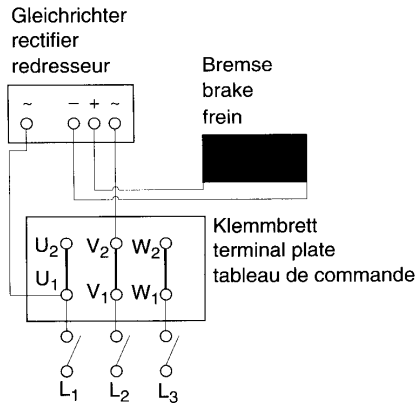

Schaltung ~230 V Δ (Dreieckschaltung)
operating ~230 V Δ (delta operating)
Raccordement ~230 V Δ (montage en triangle)

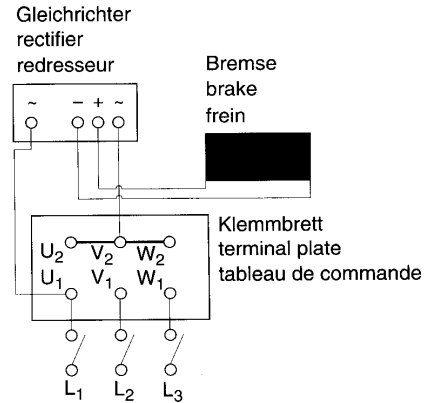

Schaltung ~400 V Y (Sternschaltung)
operating ~400 V Y (star operating)
Raccordement ~400 V Y (montage en étoile)

**gleichstromseitig geschaltet
(schnelles Bremsen)**

**d. c. - switched
(rapid braking)**

**coupe côté courant continu
(freinage rapide)**

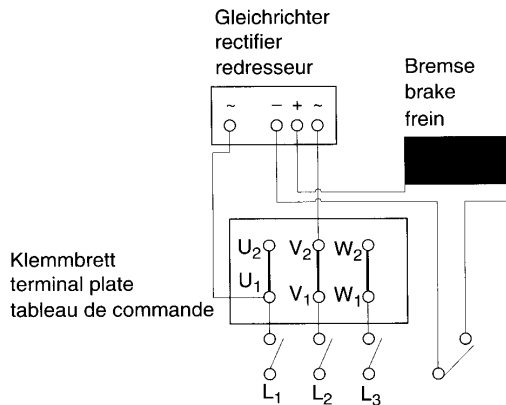

Schaltung ~230 V Δ (Dreieckschaltung)
operating ~230 V Δ (delta operating)
Raccordement ~230 V Δ (montage en triangle)

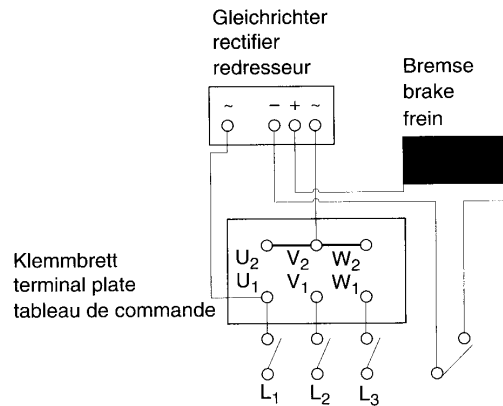

Schaltung ~400 V Y (Sternschaltung)
operating ~400 V Y (star operating)
Raccordement ~400 V Y (montage en étoile)

Technische Einzelheiten

Technical details

Détails techniques

Anordnung der Entlüftungsfilter und Ölarmaturen

Arrangement of vent filters and oil fittings

Disposition des filtres d'aération et robinetteries pour huile

**Schneckengetriebe
Schneckengetriebemotoren**

**Worm Gear Units
Worm Gear Motors**

**Réducteurs à vis sans fin
Moto-réducteurs à vis sans fin**

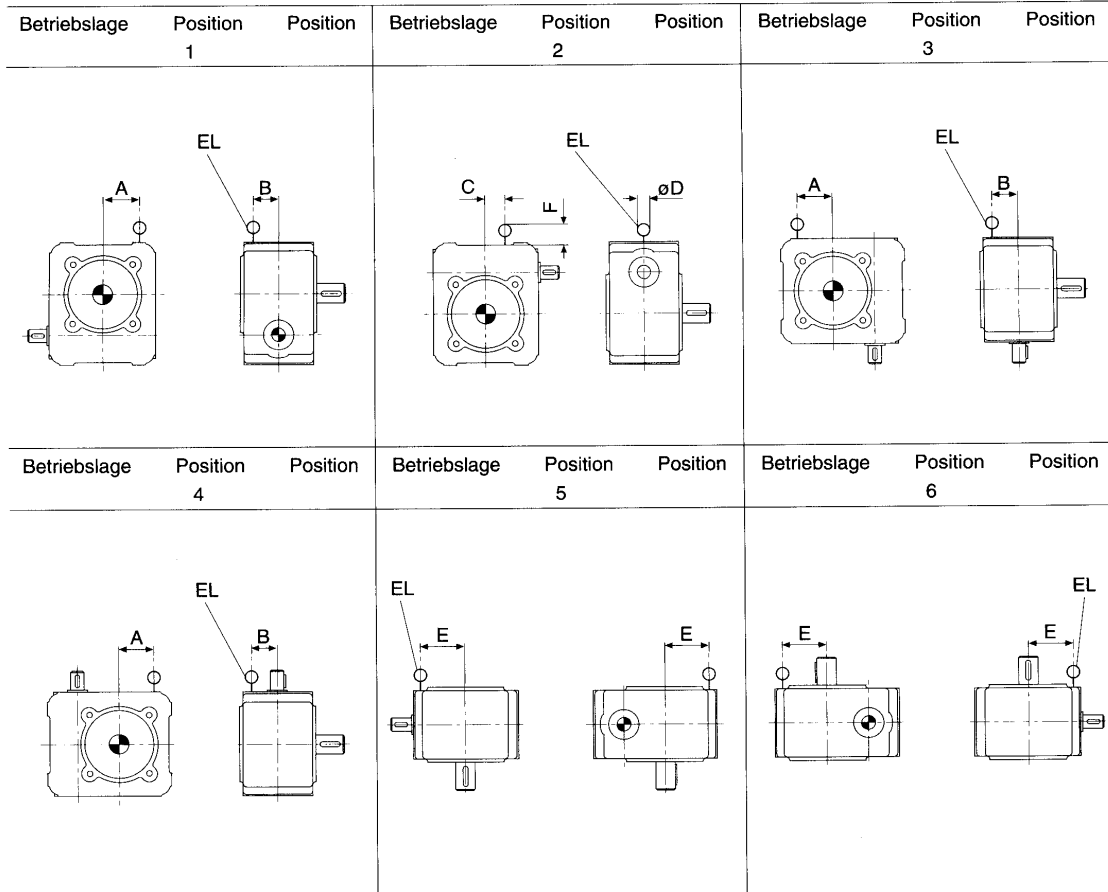

Größe / Size / Grandeur	A	B	C	D	E	F
040	-	-	-	-	-	-
050	50	20	33	22	58	25
063	62,5	27,5	37	22	67	25
080	77,5	32,5	57	22	82	25

B013C Baugröße 040 ohne Entlüftung
EL = Entlüftungsfilter

Size 040 without venting
EL = vent filter

Grandeur standard 040 sans desaerage
EL = Filtre d'aération

Technische Einzelheiten

Anordnung der Entlüftungsfiter und Ölarmaturen

**Schneckengetriebe
Schneckengetriebemotoren**

Technical details

Arrangement of vent filters and oil fittings

**Worm Gear Units
Worm Gear Motors**

Détails techniques

Disposition des filtres d'aération et robinetteries pour huile

**Réducteurs à vis sans fin
Moto-réducteurs à vis sans fin**

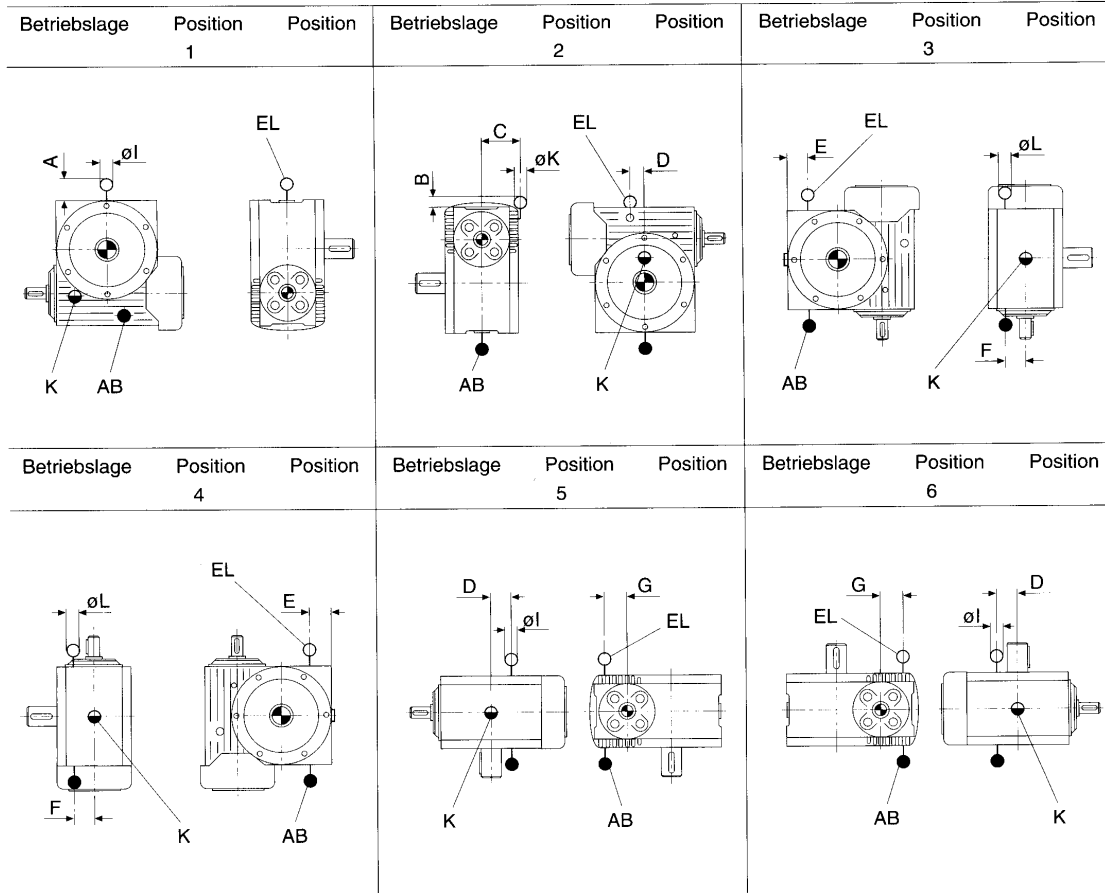

Größe / Size / Grandeur	A	B	C	D	E	F	G	I	K	L
100	32	42	95	50	80	52	60	28	28	28
125	30	37	115	55	82	55	67	46	28	28
160	37	42	130	70	95	68	85	46	46	28
200	37	41	150	80	110	84	109	46	46	28
250	37	35	160	125	100	90	113	46	46	46
315	37	-	-	135	-	-	118	46	-	-

B013C

EL = Entlüftungsfiter
AB = Ölablaß
K = Ölstandkontrollschraube

EL = vent filter
AB = oil drain
K = oil level checking plug

EL = Filtre d'aération
AB = Vidange d'huile
K = Vis de contrôle du niveau d'huile

Technische Einzelheiten

Anordnung der Entlüftungsfilter und Ölarmaturen

Stirnrad-Schneckengetriebe
Stirnrad-Schneckengetriebe
motoren

Technical details

Arrangement of vent filters and oil fittings

Helical Worm Gear Units
Helical Worm Gear Motors

Détails techniques

Disposition des filtres d'aération et robinetteries pour huile

Réducteurs à engrenages et vis sans fin
Moto-réducteurs à engrenages et vis sans fin

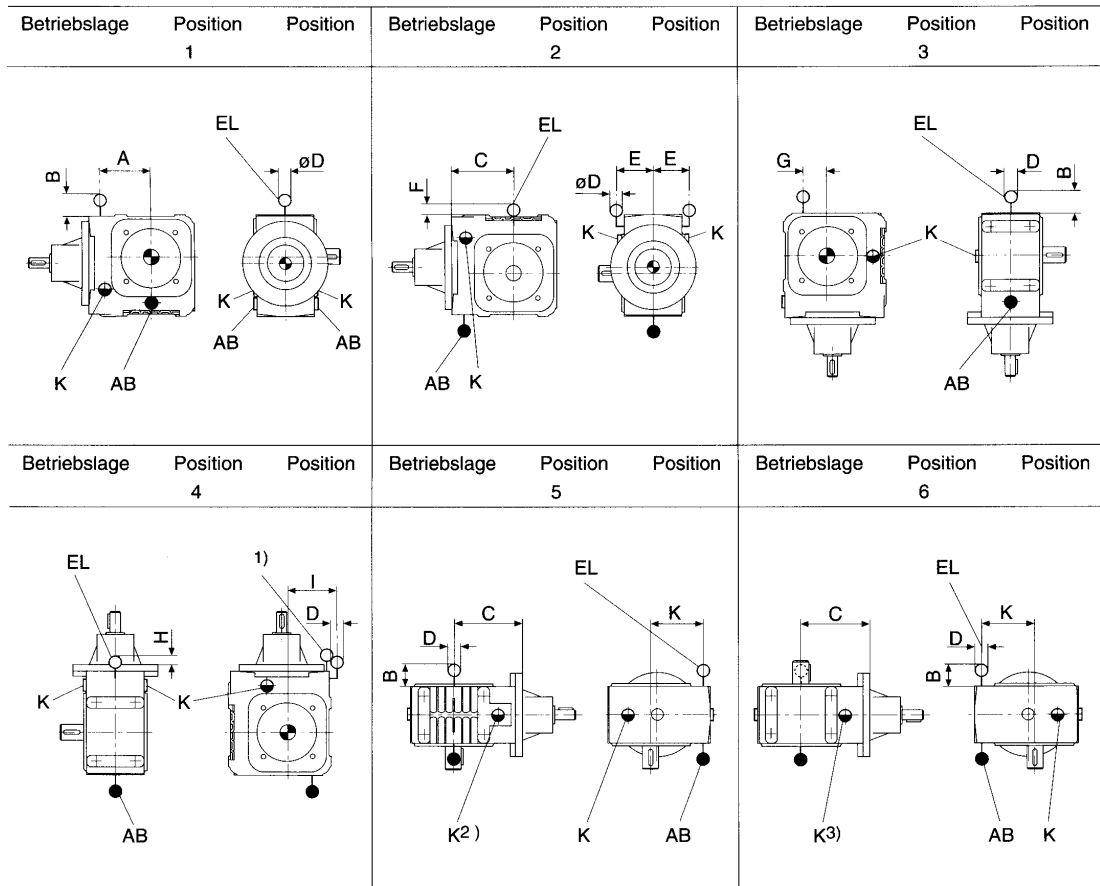

Größe / Size / Grandeur	A	B	C	D	E	F	G	H	I	K
050	98	23	116	20	62	6	25	10	80	78
063	105	23	123	20	69,5	6	35	10	92	93
080	126,5	23	149,5	20	79,5	7	42,5	5	111,25	124
100	155	30	184	28	112	18	33	27	140	142
125	188,5	30	215	28	122	21	55	30	161	190

B013C

EL = Entlüftungsfilter

AB = Ölablaß

K = Ölstandkontrollschraube

1) Entlüftung an S.3 in Sonderausführung möglich

2) an S. 1 in Sonderausführung möglich

3) wahlweise an S. 2 oder S. 4

EL = vent filter

AB = oil drain

K = oil level checking plug

1) Ventilation on side 3 possible as special design

2) on side 1 possible as special design

3) optionally on side 2 or 4

EL = Filtre d'aération

AB = Vidange d'huile

K = Vis de contrôle du niveau d'huile

1) Aération côté 3 possible dans un modèle spécial

2) côté 1 possible dans un modèle spécial

3) Au choix côté 2 ou 4