



Power transmission for your success



Operating Instructions

Elastic Couplings

RN, RNG, RNH, RNI, RNK, RNKC and RNT

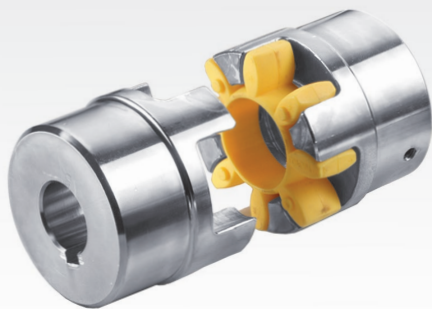
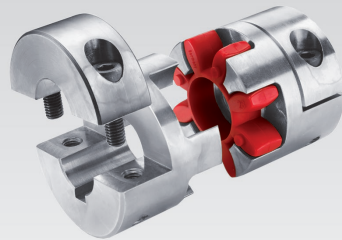

D

PCA 1, 2, 3
Subsidiary
MÄDLER GmbH
Brookstieg 16
D-22145 Stapelfeld
Tel. +49 40-60 04 75 10
hamburg@maedler.de
www.maedler.de

D

PCA 0, 4, 5
Subsidiary
MÄDLER GmbH
Bublitzer Str. 21
D-40599 Düsseldorf
Tel. +49 211-97 47 10
duesseldorf@maedler.de
www.maedler.de

D

PCA 6, 7, 8, 9
Headquarter
MÄDLER GmbH
Tränkestr. 6-8
D-70597 Stuttgart
Tel. +49 711-7 20 95 0
stuttgart@maedler.de
www.maedler.de

A

MÄDLER
Österreich GmbH
Schottenfeldgasse 14/3
A-1070 Wien
Tel. +43 1398 1398-00
info@maedler.at
www.maedler.at

CH

MÄDLER
NORM-ANTRIEB AG
Haldenstr. 14
CH-8245 Feuerthalen
Tel. +41 52 647 40 40
info@maedler.ch
www.maedler.ch





Table of contents

1	General information	3
	1.1 Safety and information symbols	3
	1.2 General hazard warnings	3
2	Intended use	3
3	Selection and Dimensioning	4
4	Storage	5
5	Dimensions	5
	5.1 Couplings in catalogue version	4
	5.2 Couplings in optionally flange version	5
		6
6	Assembly	6
	6.1 Assembly instructions	6
	6.2 Components of the coupling	7
	6.3 Spiders	7
	6.4 Assembling the coupling	8
	Tightening torques	8
	6.5 Displacement types and values	9
7	Wear and replacement	10
8	Spare parts management	10
9	Important information for Ex-zones	10
10	Additional information	10



1 General information



Carefully read through this installation manual before installing the shaft coupling. Pay particular attention to the safety instructions! The installation manual is an important document. Store it carefully and in the vicinity of the coupling. The copyright for this installation manual shall remain with MÄDLER GmbH Stuttgart, Germany. The language of the origin manual is German.

1.1 Safety and information symbols

	Danger	Risk of injury to personnel
	Caution	Damage could occur to the machine
	Note	Note regarding important information
	Caution	Notes / instructions on use in Ex zones

1.2 General hazard warnings

  The bore sizes of the couplings must not be bored bigger than the max. bore specified in the MÄDLER® catalogue. Bigger bores would reduce the hub strength. A breaking hub could damage machines and injure persons.

  During installation and removal of the MÄDLER® coupling, make sure that the entire drive train is secured to prevent accidental activation, and that the system is depressurised. Failure to handle rotating parts in the proper manner can cause serious injury. For this reason, the following safety instructions should be read and followed without exception.

- All work on the shaft coupling should be performed from the perspective of "Safety first".
- Switch off the drive unit before carrying out work on the shaft coupling.
- Secure the drive unit to prevent unintentional activation, e.g. by attaching information signs to the switch-on points or removing the fuse at the power supply.
- Do not reach into the working area of the machine while it is still in operation.
- Protect the rotating parts to prevent accidental touching. Attach the relevant protective devices and covers.

2 Intended use

The torsionally flexible shaft couplings RN, RNG, RNH, RNI, RNK and RNT have the ability to compensate angular, radial and axial displacement caused by manufacturing and assembly tolerances.

You may only install and maintain the shaft coupling if you

- have carefully read and understood the installation manual
- are authorised and trained to do so.

The shaft coupling may only be used in accordance with the technical specifications. Unauthorised structural changes to the shaft coupling are prohibited. We will not accept any liability for damage occurring as a result of this. In the interest of further development, we reserve the right to make technical changes. The shaft coupling described here corresponds with the latest technical standards at the time of publication of this installation manual. The shaft couplings RN, RNG and RNI are usually delivered without bore or with pilot bore. Reworking can be done at MÄDLER® at extra charge.

3 Selection and Dimensioning

3.1 Selection

Material of hub: The selection depends on the application.

Aluminium (types RN, RNH, RNK and RNKC): Light-weight, good corrosion-resistance in non-aggressive environment.

Stainless steel (type RNI): Very good corrosion-resistance.

Grey-cast iron (types RNG and RNT): Low-cost, with good strength.

Hardness of elastomere elements: The selection of the spiders depends on the application.

Soft 92 Shore A (yellow): High damping, for common usage.

Medium hard 98 Shore A (red) : Medium damping, for higher torques.

Hard 64° Shore D (green): Low damping, for very high torques at small torsion angle.

Standard types / backlash-free types:

Standard type couplings are very flexible and can compensate a large angular, radial and axial displacement.

The hubs and spider can get put together very easy.

Backlash-free types are very stiff and allow a backlash-free drive in the range of the spider's prestress.

The hubs and spider need some force to be put together.

Hub fixing:

Couplings RN, RNG and RNI without bore or with pilot bore must get reworked before mounting: A finished bore, keyway and grub screw thread can be done by the customer or at extra charge. The clamp-style couplings RNH, RNK and RNKC are ready to install (divergent borehole sizes and keyways are available at short time). For the taper bush coupling RNT, we provide a lot of different bush bore sizes.

3.2 Dimensioning

The dimensioning is the responsibility of the user and should be done according to DIN 740 part 2.

At drives rotating with high speed, you must pay attention to resonant vibrations. Necessarily, you have to consider the following factors:

Operating Factors

Type of Shock Load	Type of Drive Unit		
	Electric Motors Steam Turbines Shaftings	4 - 6 Cylinder Combustion Engines	1 - 3 Cylinder Combustion Engines
Weak shock load Low starting torque, uniform operation small light generators, small centrifugal pumps, small blowers, light machine tools, light transmissions	1.0	1.25	1.75
Medium shock load Medium starting torque, slight torque fluctuations larger conveying machinery, large blowers, centrifugal pumps and generators, large machine tools and wood working machines, rapid presses, flower mills and food grinders, shears, punches, grinding machines, washing machines, transmissions	1.25	1.5	2.0
Strong shock load High starting torque, strong shocks, alternating sense of rotation. centrifuges, gang saws, paper calender, roller tables, wet presses, ball and rod mills, heavy rolling mills for metal, rubber rolling mill, reciprocating machines without flywheel, cement mills, stone breakers	1.5	2.0	2.5

Temperature Factors

Temperature	-30°C to +30°C	up to +40°C	up to +60°C	up to +80°C
Factor	1.0	1.2	1.4	1.8

Starting Factors

Starts per hour	100	200	400	800
Factor	1.0	1.2	1.4	1.8

4 Storage

- Hubs from stainless steel are very corrosion resistant. Hubs from grey cast iron should be stored in a covered, dry place. If the storage will be longer than 6 months, it is recommended to conserve these hubs with oil.
- Provided that storage conditions are favourable, the properties of the spiders will remain unaltered for up to 5 years.



The storage areas must not contain any ozone-producing devices, such as fluorescent light sources, mercury-vapour lamps, or high-voltage electrical equipment. Damp storage areas are unsuitable. Make sure that no condensation is produced. A favourable relative humidity level would be below 65 %.

5 Dimensions

4.1 Couplings in catalogue version

Figure 1: Hub combination A-A, A-B and B-B

Hub versions A or B are standard, depending on the coupling type and size. Refer to MÄDLER® catalogue for the standard hub versions.

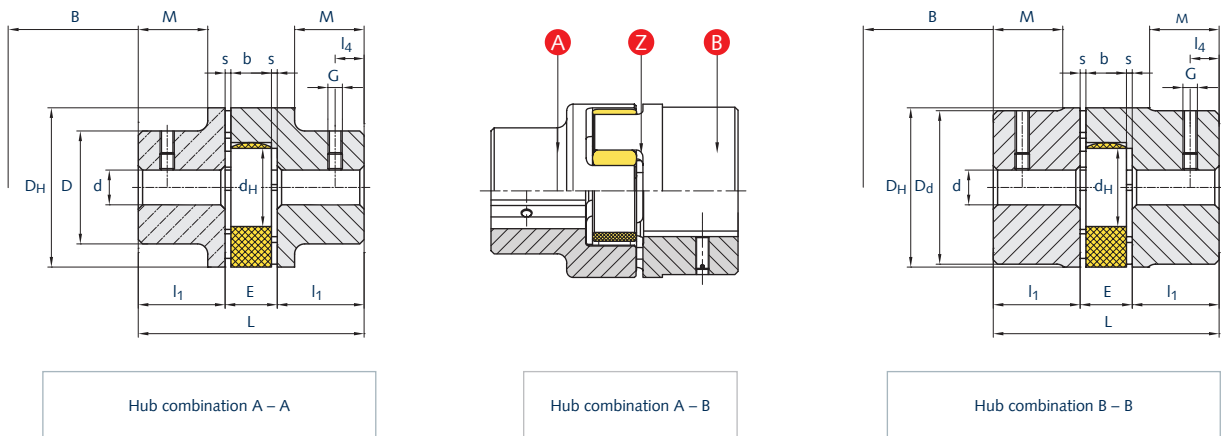

For dimensions, please refer to MÄDLER® catalogue.

4.2 Couplings in optionally flange version

Figure 2: Hub combination A-E and E-E

C and E are optional hub versions, available on request.

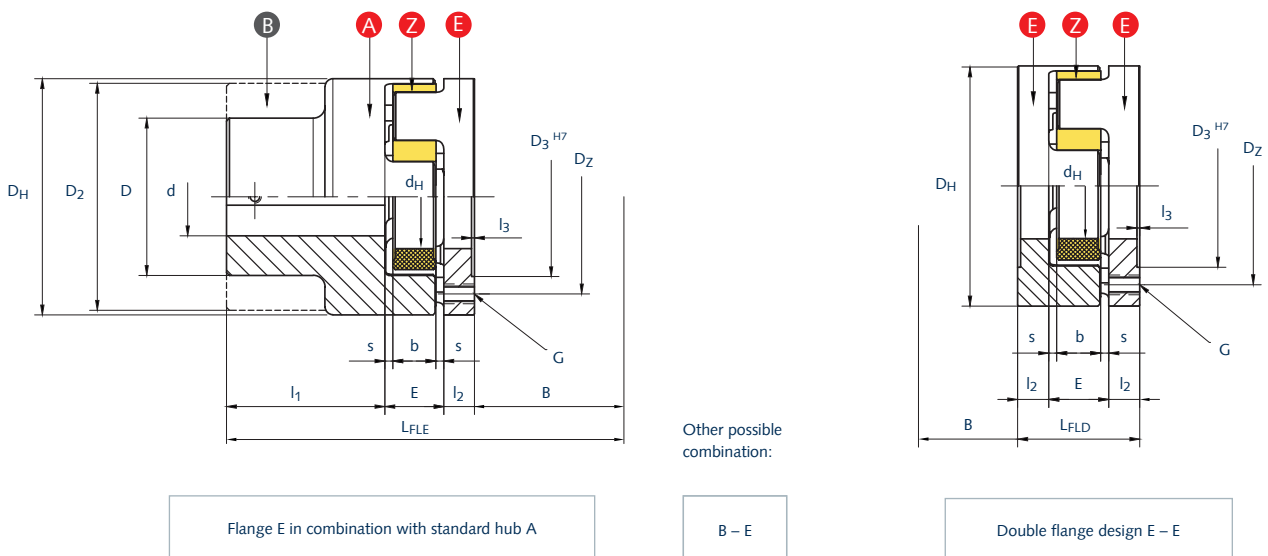

5.2.2 Couplings in optionally flange version

Figure 3: Hub combination A-C and C-C

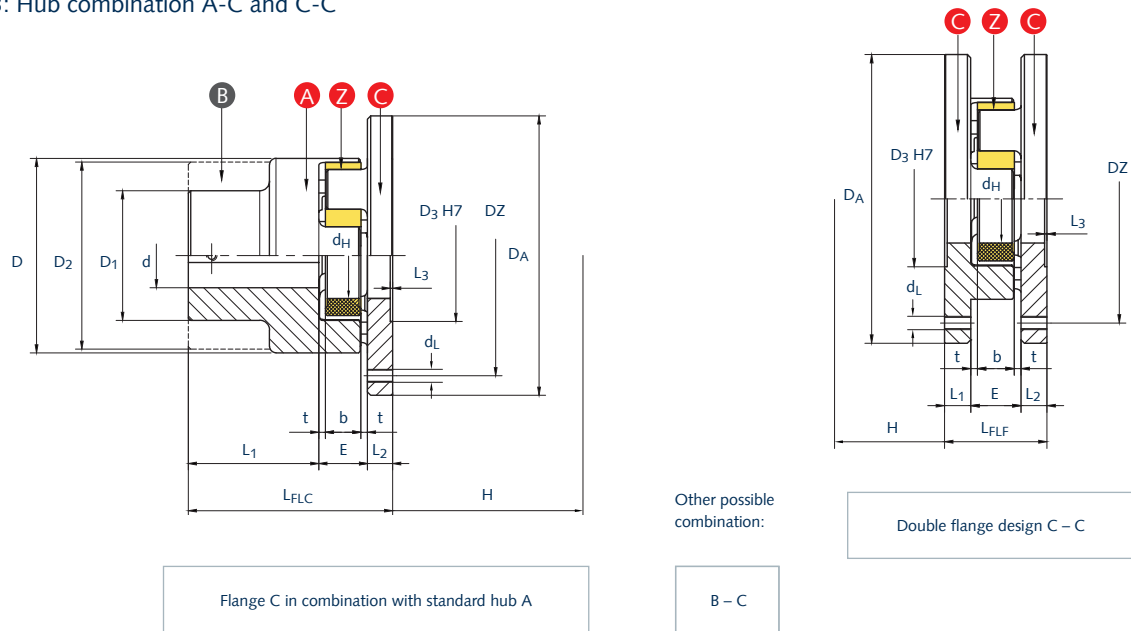

For dimensions, please refer to MÄDLER® catalogue.



Shaft couplings or couplings in use with other add-on parts could produce heat, sparks and static charges. For use in Ex-zones, there are strictly regulations. Please contact us for further information.

6 Assembly

6.1 Assembly instructions



We recommend checking the dimensional accuracy of the bore, shaft, slot and feather key before commencing assembly.



At press fit or tight fit, gently heating the hubs to approx. 80 °C makes it easier to fit them onto the shaft.



Touching the heated coupling hubs can cause burns. Wear safety gloves.



During assembly, make sure that dimension E is adhered to, so that the coupling sleeve can still move axially during use. If this instruction is not observed, the coupling cannot work properly and may be damaged.



It is vital that you pay attention to hazards from ignition sources in areas where there is a risk of explosion!

6.2 Components of the coupling

The couplings in basic style exist from two hubs and one spider. At coupling RNT, there are also two taper clamping bushes required. These taper bushes are available in different bore sizes. At RNT, there are two hub versions on choice: IS = Taper bush mounting from the inside. AS = Taper bush mounting from the outside. At RNKC and RNT couplings, all parts have to be ordered separately.

Basic style with two standard hubs and a spider:

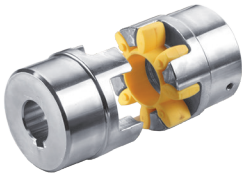

Clamp hub style:

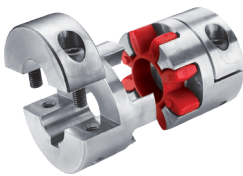

Coupling RNT, taper bush version:

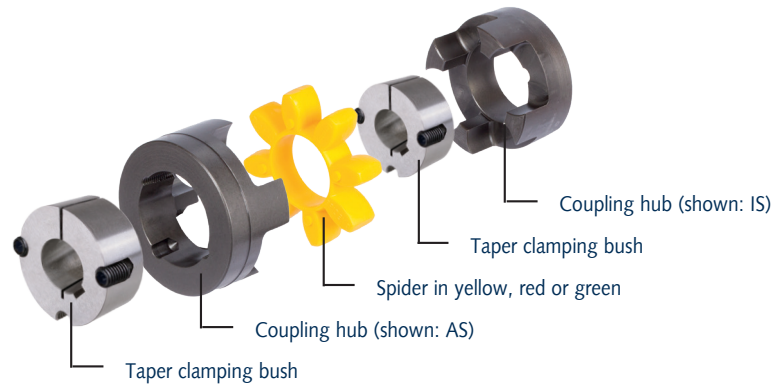

At coupling RNT, the taper bushes and the spider have to be ordered separately.

6.3 Spiders (elastic inserts)

The spiders are separately available as standard type for the normal backlash couplings or as backlash-free type for the backlash-free couplings RNH and RNK, in three different Shore-Hardnesses:
 Yellow = soft, approx. 92° Shore A (smaller sizes sometimes white). Red = medium hard, approx. 98° Shore A.
 Green = hard, approx. 64° Shore D (from other suppliers sometimes white-green).

At spiders for backlash-type couplings, the tooth flanks are spherical in axial direction. The bore is as great as possible.

At spiders for backlash-free couplings, the tooth flanks are mostly straight in axial direction. They have no bore or just a small bore.



Soft:
92° Shore A

Medium hard:
98° Shore A

Hard:
64° Shore D



Soft:
92° Shore A

Medium hard:
98° Shore A

Hard:
64° Shore D

Note for use of the different spiders

Basically, all the different spiders are interchangeable at our couplings RN, RNG, RNH, RNI, RNK and RNT and conform couplings from many other suppliers. You have to pay attention to the different torque rates in the MÄDLER® catalogue and different displacement values on page 9 in this document. Note: These stated values are for standard spiders in standard couplings, respectively for backlash-free spiders in backlash-free couplings. Spiders with hardness 64°D Shore are not recommended for taper bush couplings. At couplings made from aluminium, the effective torque should not be higher than the transmittable torque of the 98°A Shore spiders. Backlash-free couplings have not only backlash-free spiders, but also closer tooth spaces and smaller tooth space tolerances. A backlash-free spider in a standard coupling would result a coupling with more stiffness and less play than with a standard spider, but would not be really backlash-free.

6.4 Assembling the coupling

- Insert the spider into the cam geometry on one of the hubs.
- Fit the two coupling hubs onto the shafts of the drive side and the driven side.
- Connect the shafts with the coupling. The spider may get lubricated with grease (based on mineral oil or silicone lubricant).
- The correct dimension E (table 4 or 5 on page 9) is necessary for the compensation of angular and axial displacement. So it must be adjusted like shown on page 9.
- If the units on the motor and pump side are already attached, dimension E can be set by moving the coupling hubs axially on the shafts.
- Fix the hubs with the mounting screws / clamp screws. At types RN, RNG and RNI, you need keyways, keys and grub screws. For grub screws DIN EN ISO 4029 with cup point, you can find the tightening torques in table 1.
- If you are fitting a clamp-style coupling, you can find the tightening torque in table 2.
- If you are fitting a taper bush coupling, you can find the tightening torque in table 3.

Installation of taper bush coupling RNT: • Clean and degrease all contact surfaces. • Set the clamping bush into the hub making sure that all bores align. One threaded bore must always align with one of the smooth half-bores of the counterpart. • Lubricate the mounting screws and loosely screw in the threads of the component to be mounted. • Put the parallel key into the shaft (if a parallel key is used). • Push the component to be mounted onto the shaft, together with the entered bush. With feather key: Align the keyway with the parallel key. Without Feather key: Make sure the keyway of the bush is offset by 180 degrees to the shaft keyway, if there is one. • If necessary, use light blows to drive the bush into position. • Fasten the mounting screws evenly, until the max. torque is reached (see table). • Improving the fit of the bush: drive the bush further into the component to be mounted with light blows (using a wooden block or a soft metal bush). • Retighten the mounting screws with the maximum torque (see table). Alternatively the bush can also be retightened after an operating time of 30 to 60 minutes. • Fill the empty holes (used for forcing off) with grease, to protect them. • Please find the complete instruction for taper bushes on the internet at www.maedler.de in the section Downloads.

Table 1: Tightening torques in Nm for grub screws DIN EN ISO 4029 with cup point.

Thread	M4	M5	M6	M8	M10	M12
Nm	1.5	2	4	10	17	40

Table 2: Tightening torques in Nm for clamping screws DIN 912-12.9 (at clamp style coupling hubs).

Size	5	7	9	14	19-24	28-38	42	48-65
Thread	M1.6	M2	M2.5	M3	M6	M8	M10	M12
Nm	0.25	0.35	0.75	1,5	11	25	69	120

Table 3: Tightening torques in Nm for taper couplings RNT, for the mounting screws of the bushes.

Size	24	28-38	42	48	55-65	75	90
Bush No.	1008	1108	1610	1615	2012	2517	3020
Nm	5.6	5.6	20	20	30	50	90

6.4 Displacement types and values



In order to guarantee a long service life for the coupling and to avoid hazards during usage in Ex-zones, the shaft ends must be precisely aligned. It is vital to maintain the specified displacement values, see table 3. Exceeding these values will damage the coupling. The more precisely the coupling is aligned, the longer its service life will be.

Figure 4: Displacement types and values

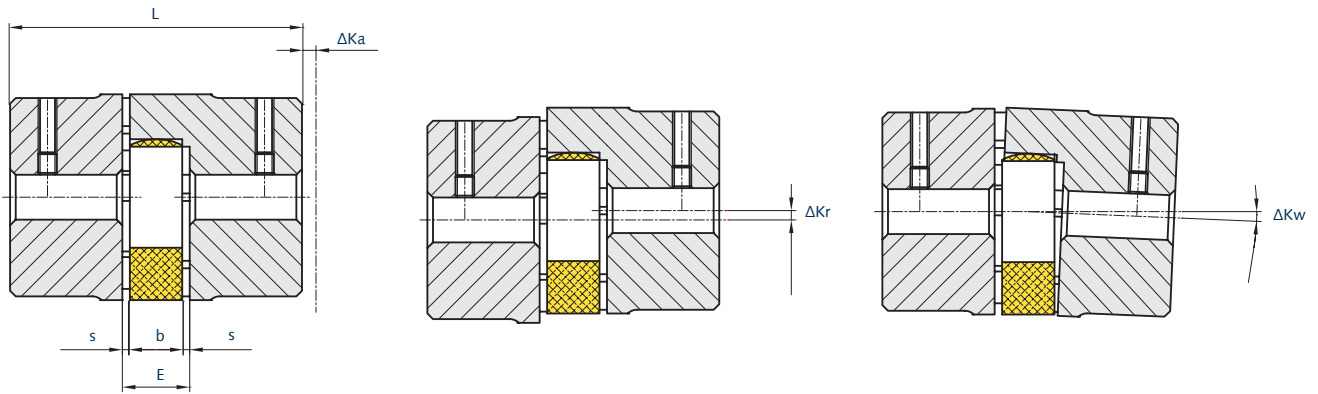

Table 4: Displacement values for standard couplings (backlash type). The values depend on the speed.

Type	Dimensions [mm]				Axial displacement ΔK_a [mm]	Radial displacement ΔK_r [mm]				Angular displacement ΔK_w [°]			
	L	E	b	s		Rotation n [min ⁻¹]				Rotation n [min ⁻¹]			
						750	1000	1500	3000	750	1000	1500	3000
7	22	8	6	1,0	+0,6 / -0,3	0,10	0,09	0,07	0,05	1,0	1,0	0,9	0,8
9	30	10	8	1,0	+0,8 / -0,4	0,13	0,12	0,09	0,07	1,0	1,0	0,9	0,8
14	35	13	10	1,5	+1,0 / -0,5	0,22	0,20	0,16	0,11	1,3	1,3	1,2	1,1
19	66	16	12	2,0	+1,2 / -0,5	0,27	0,24	0,20	0,13	1,3	1,3	1,2	1,1
24	78	18	14	2,0	+1,4 / -0,5	0,30	0,27	0,22	0,15	1,1	1,0	0,9	0,8
28	90	20	15	2,5	+1,5 / -0,7	0,34	0,30	0,25	0,17	1,1	1,0	0,9	0,8
38	114	24	18	3,0	+1,8 / -0,7	0,38	0,35	0,28	0,19	1,1	1,1	1,0	0,8
42	126	26	20	3,0	+2,0 / -1,0	0,43	0,38	0,32	0,21	1,1	1,1	1,0	0,8
48	140	28	21	3,5	+2,1 / -1,0	0,50	0,44	0,36	0,25	1,2	1,2	1,1	0,9
55	160	30	22	4,0	+2,2 / -1,0	0,54	0,46	0,38	0,26	1,2	1,2	1,1	1,0
65	185	35	26	4,5	+2,6 / -1,0	0,56	0,50	0,42	0,28	1,2	1,2	1,2	1,0
75	210	40	30	5,0	+3,0 / -1,5	0,65	0,58	0,48	0,32	1,3	1,2	1,2	1,0
90	245	45	34	5,5	+3,4 / -1,5	0,68	0,60	0,50	0,34	1,3	1,3	1,2	1,1
100	270	50	38	6,0	+3,8 / -1,5	0,71	0,64	0,52	0,36	1,3	1,3	1,2	1,1

Table 5: Displacement values for backlash-free couplings. The values depend on the hardness of the spider.

Type	Dimensions [mm]				Axial displacement ΔK_a [mm]	Radial displacement ΔK_r [mm]			Angular displacement ΔK_w [°]		
	L	E	b	s		Shore Hardness			Shore Hardness		
						92° A	98° A	64° D	92° A	98° A	64° D
5	15	5	k.A.	k.A.	+0,4 / -0,2	0,06	-	-	1,0	-	-
7	22	8	6	1,0	+0,6 / -0,3	0,10	-	-	1,0	-	-
9	30	10	8	1,0	+0,8 / -0,4	0,13	-	-	1,0	-	-
14	35	13	10	1,5	+1,0 / -0,5	0,13	0,09	0,06	1,0	0,9	0,8
19	66	16	12	2,0	+1,2 / -0,5	0,10	0,06	0,04	1,0	0,9	0,8
24	78	18	14	2,0	+1,4 / -0,5	0,14	0,10	0,07	1,0	0,9	0,8
28	90	20	15	2,5	+1,5 / -0,7	0,15	0,11	0,08	1,0	0,9	0,8
38	114	24	18	3,0	+1,8 / -0,7	0,17	0,12	0,09	1,0	0,9	0,8
42	126	26	20	3,0	+2,0 / -1,0	0,19	0,14	0,10	1,0	0,9	0,8
48	140	28	21	3,5	+2,1 / -1,0	0,23	0,16	0,11	1,0	0,9	0,8
55	160	30	22	4,0	+2,2 / -1,0	0,24	0,17	0,12	1,0	0,9	0,8



- The displacement values stated in the tables are maximum values, which must not occur at the same time at the maximum value. If radial and angular displacements do occur simultaneously, the permissible displacement values may only be used proportionately.
- Use a measuring gauge, ruler or feeler gauge to check the displacement values.

7 Wear and replacement

The spiders are wear parts. The wear-off depends on the application: turn-on-duration, number of starts, values of shaft displacement and so on. At backlash types, the spiders should be replaced, if the measure X in the table is exceeded. At backlash-free types, the spider must be replaced, when the angular torsion, caused by the starting torque, will be to large for the application.

Size	Wear-off limit
	X max. [mm]
5	k. A.
7	k. A.
9	2
14	2
19	3
24	3
28	3
38	3
42	4
48	4
55	5
65	5
75	6
90	8
100	9



The measure X can be checked with a feeler gauge.

8 Spare parts management



Having important spare parts in stock at the installation location is a basic requirement for ensuring the operational readiness of the coupling.



For spare parts/ordering, please refer to the MÄDLER® catalogue or the internet at www.maedler.de

9 Important information for Ex-zones



Shaft couplings used with other add-on parts could produce heat, sparks and static charges.

For use in Ex-zones, there are strictly regulations.

Please contact us for the information for EX zone applications.

10 Additional information



The customer bears sole responsibility for all subsequent machining on the coupling components, which are not performed by MÄDLER®. All claims for warranty are excluded.