



Operating instructions

Frequency Inverter NES1



D

PCA 1, 2, 3
Subsidiary
MÄDLER GmbH
Brookstieg 16
D-22145 Stapelfeld
Tel. +49 40-60 04 75 10
hamburg@maedler.de
www.maedler.de

D

PCA 0, 4, 5
Subsidiary
MÄDLER GmbH
Bublitzer Str. 21
D-40599 Düsseldorf
Tel. +49 211-97 47 10
duesseldorf@maedler.de
www.maedler.de

D

PCA 6, 7, 8, 9
Headquarter
MÄDLER GmbH
Tränkestr. 6-8
D-70597 Stuttgart
Tel. +49 711-7 20 95 0
stuttgart@maedler.de
www.maedler.de

A

MÄDLER
Österreich GmbH
Schottenfeldgasse 14/3
A-1070 Wien
Tel. +43 1398 1398-00
info@maedler.at
www.maedler.at

CH

MÄDLER
NORM-ANTRIEB AG
Haldenstr. 14
CH-8245 Feuerthalen
Tel. +41 52 647 40 40
info@maedler.ch
www.maedler.ch

Introduction

Introduction

Thank you for purchasing the Hitachi NE-S1 Series Inverter.

This Quick Reference Guide describes how to handle and maintain the Hitachi NE-S1 Series Inverter.

Read this Quick Reference Guide carefully before using the inverter, and then keep it handy for those who operate, maintain, and inspect the inverter.

Before and during the installation, operation, inspection, and maintenance of the inverter, always refer to this Quick Reference Guide to obtain the necessary related knowledge, and ensure you understand and follow all safety information, precautions, and operating and handling instructions for the correct use of the inverter.

Always use the inverter strictly within the range of the specifications described in this Quick Reference Guide and correctly implement maintenance and inspections to prevent faults occurring.

When using the inverter together with optional products, also read the manuals for those products. Note that this Quick Reference Guide and the manual for each optional product to be used should be delivered to the end user of the inverter.

Handling of this Quick Reference Guide

- The contents of this Quick Reference Guide are subject to change without prior notice.
- Even if you lose this Quick Reference Guide, it will not be resupplied, so please keep it carefully.
- No part of this Quick Reference Guide may be reproduced in any form without the publisher's permission.
- If you find any incorrect description, missing description or have a question concerning the contents of this Quick Reference Guide, please contact the publisher.

Revision History

No.	Revision content	Date of issue	Manual code
1	First edition	July,2012	NT3411X
2	Addition 400VClass.	May,2013	NT3411AX
3	Addition FFM option.	May,2013	NT3411BX
4	Addition China ver. And Europe Ver.	Aug.2013	NT3411CX
5	Addition 040H	Sep.2013	NT3411DX

- The current edition of this Quick Reference Guide also includes some corrections of simple misprints, missing letters, misdescriptions and certain added explanations other than those listed in the above Revision History table.

Chapter 1 Safety Instructions

1.1 Safety Instructions 1 - 1
 1.2 Precautions Concerning Electromagnetic Compatibility (EMC) 1 - 5
 1.3 Precautions Concerning Compliance with UL and cUL Standards 1 - 10

Chapter 2 Inspection of the Purchased Product

2.1 Inspection of the Purchased Product 2 - 1
 2.2 Method of Inquiry and Product Warranty 2 - 2

Chapter 3 Exterior Views

3.1 Exterior Views and Names of Parts 3 - 1
 3.2 Name of each portion (removing the front cover) 3 - 2

Chapter 4 Installation

4.1 Precautions for installation 4 - 1

Chapter 5 Wiring

5.1 Precautions for Wiring 5 - 1
 5.2 How to attach and remove the front cover 5 - 2
 5.3 How to attach the Exclusive operator (NES1-OP) 5 - 3
 5.4 Wiring and terminal description 5 - 4
 5.5 Mains wiring 5 - 7
 5.6 Wiring of the control circuit 5 - 12
 5.7 Connection with the programmable controller (PLC) 5 - 14
 5.8 Notes on using multiple inverters 5 - 15

Chapter 6 Operation

6.1 Precautions of Operation 6 - 1
 6.2 Confirmation before power up the inverter 6 - 2
 6.3 Changing parameters 6 - 2
 6.4 Power up the inverter 6 - 3
 6.5 How To Operate the Inverter 6 - 4
 6.6 Motor Operation 6 - 11
 6.7 Test Run with the motor 6 - 17
 6.8 When tripping occurs 6 - 19

Chapter 7 Explanation of Functions

7.1	Monitoring the data	7 - 1
7.1.1	Output frequency monitoring (d001)	7 - 1
7.1.2	Output current monitoring (d002).....	7 - 1
7.1.3	Rotation direction monitoring (d003).....	7 - 1
7.1.4	Process variable (PV), PID feedback monitoring (d004,A071,A075).....	7 - 1
7.1.5	Intelligent input terminal status (d005)	7 - 2
7.1.6	Intelligent output terminal status (d006).....	7 - 2
7.1.7	Scaled output frequency monitoring (d007,b086)	7 - 2
7.1.8	Output voltage monitoring (d013)	7 - 3
7.1.9	Input power monitoring (d014)	7 - 3
7.1.10	Cumulative power monitoring (d015,b078,b079)	7 - 3
7.1.11	Cumulative operation RUN time monitoring (d016).....	7 - 3
7.1.12	Cumulative power-on time monitoring (d017)	7 - 3
7.1.13	Heat sink temperature monitoring (d018)	7 - 3
7.1.14	Dual monitoring (d050,b160,b161).....	7 - 4
7.1.15	Trip Counter (d080)	7 - 4
7.1.16	Trip monitoring 1 to 6 (d081 to d086).....	7 - 4
7.1.17	Warning monitoring (d090).....	7 - 5
7.1.18	DC voltage monitoring (d102)	7 - 5
7.1.19	Electronic thermal overload monitoring (d104).....	7 - 5
7.2	Using the basic functions.....	7 - 6
7.2.1	Frequency source setting and Output frequency setting (F001,A001,A020/A220,C001 to C005).....	7 - 6
7.2.2	Run command source setting (A002/A202,C001 to C005,F004).....	7 - 7
7.2.3	Keypad Run key routing (F004).....	7 - 7
7.2.4	Rotational direction restriction (b035)	7 - 7
7.2.5	Stop mode selection (b091,F003/F203,b003,b007,b008)	7 - 8
7.2.6	Acceleration/deceleration time setting (F002/F202, F003/F203, A004/A204, C001 to C005)	7 - 8
7.2.7	Base frequency setting (A003/A203, A082/A282).....	7 - 9
7.2.8	Using the AVR Functions (A081/A281, A082/A282, A083, A084)	7 - 9
7.2.9	Maximum frequency setting (A004/A204)	7 - 11
7.2.10	Carrier frequency setting (b083).....	7 - 11
7.3	Setting the intelligent I/O terminal function.....	7 - 12
7.3.1	Intelligent input terminal setting (C001 to C005).....	7 - 12
7.3.2	Input terminal a/b (NO/NC) selection (C011 to C015).....	7 - 12
7.3.3	Input terminal response time (C160 to C164)	7 - 13
7.3.4	Intelligent output terminal setting (C021,C026)	7 - 13
7.3.5	Intelligent output terminal a/b (NO/NC) selection (C031,C036).....	7 - 14
7.3.6	Output signal delay/hold function (C130,C131,C140,C141)	7 - 15
7.4	Using the analog terminal.....	7 - 16
7.4.1	Analog input (O/OI)	7 - 16
7.4.2	External analog input (O/OI) filter setting (A016)	7 - 16
7.4.3	Analog command holding function (AHD) (C101,C001 to C005).....	7 - 17
7.4.4	Analog Input Adjustment (C081).....	7 - 17
7.4.5	Start/end frequency setting for external analog input (A011 to A015)	7 - 18
7.4.6	FM terminal (C027,C030,C105,b081).....	7 - 19

7.5	To drive the motor.....	7 - 20
7.5.1	V/f characteristic curve selection (A044/A244,b100 to b113)	7 - 20
7.5.2	Torque boost setting (A041/A241,A042/A242, A043/A243,H003/H203,b H004/H204)	7 - 22
7.5.3	3-wire interface operation function (STA, STP, and F/R) (C001 to C005)	7 - 23
7.5.4	Start frequency setting (b082).....	7 - 24
7.5.5	Reduced voltage start function (b036,b082).....	7 - 24
7.5.6	Jogging (JG) command setting (A038,A039,C001 to C005)	7 - 25
7.5.7	Frequency upper limit setting (A061/A261,A062/A262)	7 - 26
7.5.8	Jump frequency function (A063 to A068).....	7 - 26
7.5.9	Acceleration/Deceleration hold frequency setting (A069,A070,A154,A155).....	7 - 27
7.5.10	Permission of Run command function (ROK) (C001 to C005).....	7 - 27
7.5.11	Multispeed select setting (CF1 to CF3 and SF1 to SF3) (A019,A020/A220,A021 to A027,C001 to C005,C169)	7 - 28
7.5.12	Two-stage acceleration/deceleration function (2CH) (A092/A292 to A096/A296).....	7 - 29
7.5.13	Acceleration/deceleration curve selection (A097,A098,A131,A132)	7 - 30
7.5.14	Frequency operation function (A141,A142,A143,A001,A076)	7 - 31
7.5.15	Frequency addition function (A145,A146,C001 to C005)	7 - 32
7.5.16	Remote control function (UP and DWN) (C101,C001 to C005).....	7 - 32
7.5.17	V/f gain setting (A045/A245,A082/A282).....	7 - 33
7.5.18	PID function (A071 to A078,C044,C052,C053).....	7 - 34
7.5.19	Energy-saver operation (A085,A086)	7 - 39
7.5.20	Stabilization constant setting (H006/H206,A045,b083)	7 - 39
7.5.21	2 nd motor control function (SET) (C001 to C005).....	7 - 40
7.5.22	DC braking (DB) setting (A051 to A059,C001 to C005)	7 - 41
7.6	Functions related to the operator display	7 - 45
7.6.1	STOP key enable (b087).....	7 - 45
7.6.2	Software lock (SFT) function (b031,C001 to C005).....	7 - 45
7.6.3	Forcible-operation from digital operator (OPE) function (A001,A002,C001 to C005).....	7 - 45
7.6.4	Forcible-operation from terminal (F-TM) function (A001,A002,C001 to C005).....	7 - 46
7.6.5	Action selection in case of external operator disconnection (b165)	7 - 46
7.6.6	Initial-screen selection (selection of the initial screen to be displayed after power-on) (b038)	7 - 46
7.6.7	Select automatic return to the initial display (b164).....	7 - 47
7.6.8	NES1-OP display selection (b150).....	7 - 47
7.6.9	Data Read/Write selection (b166).....	7 - 47
7.6.10	Display limitation function (DISP) (C001 to C005)	7 - 47
7.6.11	Function code display restriction (b037).....	7 - 48
7.6.12	Button sensitivity selection (C151).....	7 - 49
7.6.13	Scroll sensitivity selection (C152)	7 - 50
7.7	Functions about restarting	7 - 51
7.7.1	Retry (Under Voltage , Over Current / Over Voltage) (b001 to b005,b007,b008,C021,C026).....	7 - 51
7.7.2	Reset (RS) function (b003,b007,C102,C103,C001 to C005).....	7 - 55
7.7.3	Free-run stop (FRS) function (b003,b007,b028 to b030,b088,C001 to C005)	7 - 56
7.7.4	Unattended start protection (USP) function (C001 to C005)	7 - 57
7.7.5	Deceleration and stopping at power failure (nonstop deceleration at instantaneous power failure) (b050 to b054)	7 - 58

Contents

7.8	Set functions related to protection and warning, each output signal	7 - 60
7.8.1	Trip signal (AL)	7 - 60
7.8.2	Electronic thermal protection (b012/b212,b013/b213,b015 to b020,C021,C026,C061)	7 - 61
7.8.3	Overload restriction/overload notice (b021 to b026,C001 to C005,C021,C026,C040,C041)	7 - 63
7.8.4	Overcurrent restraint (b027)	7 - 64
7.8.5	Over voltage suppression during deceleration (b130 to b134)	7 - 65
7.8.6	External trip (EXT) function (C001 to C005)	7 - 66
7.8.7	Automatic carrier frequency reduction (b083,b089)	7 - 67
7.8.8	Running signal (RUN) (C021)	7 - 68
7.8.9	Frequency arrival signals (FA1, FA2, FA3) (C021,C042,C043)	7 - 68
7.8.10	Running time over and power-on time over signals (RNT and ONT) (b034,C021,C026,d016,d017)	7 - 70
7.8.11	0 Hz speed detection signal (ZS) (A044/A244,C021,C063)	7 - 70
7.8.12	Logical output signal operation function (LOG1) (C021,C026,C142,C143,C144)	7 - 71
7.8.13	Communication line disconnection signal (NDc) (C021,C026,C077)	7 - 72
7.8.14	Starting contact signal (FR) (C021,C026)	7 - 72
7.8.15	Heat sink overheat warning signal (OHF) (C021,C026,C064)	7 - 72
7.8.16	Low-current indication (LOC) signal (C021,C026,C038,C039)	7 - 73
7.8.17	Inverter ready signal (IRDY) (C021,C026)	7 - 73
7.8.18	Forward rotation signal (FWR) (C021,C026)	7 - 73
7.8.19	Reverse rotation signal (RVR) (C021,C026)	7 - 74
7.8.20	Major failure signal (MJA) (C021,C026)	7 - 74
7.8.21	Window comparators (WC) (detection of terminal disconnection: Dc) (C021,C026,b060 to b062,b070)	7 - 75
7.8.22	Frequency command source (FREF)	7 - 76
7.8.23	RUN command source (REF)	7 - 76
7.8.24	2nd Motor in operation (SETM)	7 - 76
7.8.25	Ground fault detection (C155)	7 - 76
7.8.26	Out phase loss detection (C157)	7 - 76
7.9	Initializing	7 - 77
7.9.1	Initialization setting (b084,b085,b180)	7 - 77

Chapter 8 Communication Functions

8.1	Communication Specification	8 - 1
8.2	Connecting the Inverter to Modbus	8 - 2
8.3	Modbus setting procedure	8 - 3
8.4	Modbus Communication parameter	8 - 4
8.5	Modbus Protocol Reference	8 - 5
8.6	Explanation of function codes	8 - 9
8.7	Re-calculate the internal variable	8 - 18
8.8	Modbus Data Listing	8 - 19

Chapter 9 Error Codes

9.1	Indication of the error	9 - 1
9.2	Error Codes and Troubleshooting	9 - 3

9.3 Warning Codes for Digital operator 9 - 5
 9.4 Other Display for Digital operator 9 - 6

Chapter 10 Troubleshooting

Troubleshoong tips 10 - 1

Chapter 11 Maintenance and Inspection

11.1 Precautions for Maintenance and Inspection 11 - 1
 11.2 Daily and Periodic Inspections 11 - 2
 11.3 Ground Resistance Test with a Megger 11 - 3
 11.4 Withstand Voltage Test 11 - 3
 11.5 Methods of Measuring the Input/Output Voltages, Current, and Power 11 - 4
 11.6 Capacitor Life Curves 11 - 5

Chapter 12 Specifications

12.1 Specifications 12- 1
 12.2 Dimensions 12- 2
 12.3 Derating Curves 12- 3

Chapter 13 Option

13.1 Digital Operator 13- 1
 13.2 Top cover for exclusive use of NE-S1series : NES1-FFM-M 13- 55

Appendix

Appendix A Appendix- 1

Index

Index Index - 1

Chapter 1 Safety Instructions

This chapter describes the Safety instructions.

1.1	Safety Instructions.....	1 - 1
1.2	Precautions Concerning Electromagnetic Compatibility (EMC).....	1 - 5
1.3	Precautions Concerning Compliance with UL and cUL Standards	1 - 10

1.1 Safety Instructions

Be sure to read this Quick Reference Guide and appended documents thoroughly before installing, operating, maintaining, or inspecting the inverter.

In this Quick Reference Guide, safety instructions are classified into two levels, namely WARNING and CAUTION.



WARNING : Indicates that incorrect handling may cause hazardous situations, which may result in serious personal injury or death.



CAUTION : Indicates that incorrect handling may cause hazardous situations, which may result in moderate or slight personal injury or physical damage alone.

Note that even a  level situation may lead to a serious consequence according to circumstances. Be sure to follow every safety instruction, which contains important safety information. Also focus on and observe the items and instructions described under "Notes" in the text.

CAUTION

Many of the drawings in this Quick Reference Guide show the inverter with covers and/or parts blocking your view being removed.

Do not operate the inverter in the status shown in those drawings. If you have removed the covers and/or parts, be sure to reinstall them in their original positions before starting operation, and follow all instructions in this Quick Reference Guide when operating the inverter.

1. Installation

CAUTION

- Install the inverter on a non-flammable surface, e.g., metal. Otherwise, you run the risk of fire.
- Do not place flammable materials near the installed inverter. Otherwise, you run the risk of fire.
- When carrying the inverter, do not hold its top cover. Otherwise, you run the risk of injury by dropping the inverter.
- Prevent foreign matter (e.g., cut pieces of wire, sputtering welding materials, iron chips, wire, and dust) from entering the inverter. Otherwise, you run the risk of fire.
- Install the inverter on a structure able to bear the weight specified in the Instruction Manual. Otherwise, you run the risk of injury due to the inverter falling.
- Install the inverter on a vertical wall that is free of vibrations. Otherwise, you run the risk of injury due to the inverter falling.
- Do not install and operate the inverter if it is damaged or its parts are missing. Otherwise, you run the risk of injury.
- Install the inverter in a well-ventilated indoor site not exposed to direct sunlight. Avoid places where the inverter is exposed to high temperature, high humidity, condensation, dust, explosive gases, corrosive gases, flammable gases, grinding fluid mist, or salt water. Otherwise, you run the risk of fire.
- The inverter is precision equipment. Do not allow it to fall or be subject to high impacts, step on it, or place a heavy load on it. Doing so may cause the inverter to fail.

Chapter 1 Safety Instructions

2. Wiring



WARNING

- Be sure to ground the inverter. Otherwise, you run the risk of electric shock or fire.
- Commit wiring work to a qualified electrician. Otherwise, you run the risk of electric shock or fire.
- Before wiring, make sure that the power supply is off. Otherwise, you run the risk of electric shock or fire.
- Perform wiring only after installing the inverter. Otherwise, you run the risk of electric shock or injury.
- The inverter must be powered OFF before you change any of the slide switch settings. Otherwise, you run the risk of electric shock or injury.



CAUTION

- Make sure that the voltage of AC power supply matches the rated voltage of your inverter. Otherwise, you run the risk of injury or fire.
- Do not input single-phase power into the 3-phase inverter. Otherwise, you run the risk of fire.
- Do not connect AC power supply to any of the output terminals (U, V, and W). Otherwise, you run the risk of injury or fire.
- NE-S1 series inverter do not have terminals for braking resistor. Do not connect the resistor. Otherwise there is a risk of fire.
- Connect an earth-leakage breaker to the power input circuit. Otherwise, you run the risk of fire.
- Use only the power cables, earth-leakage breaker, and magnetic contactors that have the specified capacity (ratings). Otherwise, you run the risk of fire.
- Do not use the magnetic contactor installed on the primary and secondary sides of the inverter to stop its operation.
- Tighten each screw to the specified torque. No screws must be left loose. Otherwise, you run the risk of fire.
- Before operating slide switch in the inverter, be sure to turn off the power supply. Otherwise, you run the risk of electric shock and injury.
- Please make sure that earth screw was tighten completely in advance.
- First, check the tightening the screws of output terminal (U, V and W), and then tighten the screws of input terminal (R,S and T)

3. Operation

WARNING

- While power is supplied to the inverter, do not touch any terminal or internal part of the inverter, check signals, or connect or disconnect any wire or connector. Otherwise, you run the risk of electric shock or fire.
- Be sure to close the top cover before turning on the inverter power. Do not open the top while power is being supplied to the inverter or voltage remains inside. Otherwise, you run the risk of electric shock.
- Do not operate switches with wet hands. Otherwise, you run the risk of electric shock.
- While power is supplied to the inverter, do not touch the terminal of the inverter, even if it has stopped. Otherwise, you run the risk of injury or fire.
- If the retry mode has been selected, the inverter will restart suddenly after a break in the tripping status. Stay away from the machine controlled by the inverter when the inverter is under such circumstances. (Design the machine so that human safety can be ensured, even when the inverter restarts suddenly.) Otherwise, you run the risk of injury.
- Do not select the retry mode for controlling an elevating or traveling device because output free-running status occurs in retry mode. Otherwise, you run the risk of injury or damage to the machine controlled by the inverter.
- If an operation command has been input to the inverter before a short-term power failure, the inverter may restart operation after the power recovery. If such a restart may put persons in danger, design a control circuit that disables the inverter from restarting after power recovery. Otherwise, you run the risk of injury.
- Prepare the additional emergency stop switch in addition to the stop key of the integrated operator and/or the optional operator. Otherwise, there is a danger of injury.
- If an operation command has been input to the inverter before the inverter enters alarm status, the inverter will restart suddenly when the alarm status is reset. Before resetting the alarm status, make sure that no operation command has been input.
- While power is supplied to the inverter, do not touch any internal part of the inverter or insert a bar in it. Otherwise, you run the risk of electric shock or fire.
- Run/Stop/Reset is integrated in one button, before you press the button, please make sure that the machine(facility)
Otherwise, you run the risk of injury or damage to the machine controlled by the inverter.

CAUTION

- Do not touch the heat sink, which heats up during the inverter operation. Otherwise, you run the risk of burn injury.
- The inverter allows you to easily control the speed of motor or machine operations. Before operating the inverter, confirm the capacity and ratings of the motor or machine controlled by the inverter. Otherwise, you run the risk of injury.
- Install an external brake system if needed. Otherwise, you run the risk of injury.
- When using the inverter to operate a standard motor at a frequency of over 60 Hz, check the allowable motor speeds with the manufacturers of the motor and the machine to be driven and obtain their consent before starting inverter operation. Otherwise, you run the risk of damage to the motor and machine.
- During inverter operation, check the motor for the direction of rotation, abnormal sound, and vibrations. Otherwise, you run the risk of damage to the machine driven by the motor.
- Regardless Run command setting(A002/A202) if the key is pressed, inverter starts running. Therefore, if you selected Run command such as operator or terminal, please handle the key after you made sure that the machine/facility is operated safety.

Chapter 1 Safety Instructions

4. Maintenance and inspection

 **WARNING**

- Before inspecting the inverter, be sure to turn off the power supply and wait for 10 minutes or more. Otherwise, you run the risk of electric shock.
(Before inspection, confirm that the Charge lamp on the inverter is off.)
In case the power indication of the operator does not turn ON after power-up, inverter may be damaged. In that case, the inspection must be done after waiting two hours or more of the power OFF. Otherwise there is a danger of electric shock and/or injury.
- Commit only a designated person to maintenance, inspection, and the replacement of parts.
(Be sure to remove wristwatches and metal accessories, e.g., bracelets, before maintenance and inspection work and to use insulated tools for the work.) Otherwise, you run the risk of electric shock and injury.

5. Others

 **WARNING**

- Never modify the inverter. Otherwise, you run the risk of electric shock and injury.

 **CAUTION**

- Do not discard the inverter with household waste. Contact an industrial waste management company in your area who can treat industrial waste without polluting the environment.

1.2 Precautions Concerning Electromagnetic Compatibility (EMC)

CE-EMC Installation Guidelines

You are required to satisfy the EMC directive (2004/108/EC) when using a NE-S1 inverter in an EU country.

To satisfy the EMC directive and to comply with standard, you need to use a dedicated EMC filter suitable for each model, and follow the guidelines in this section. Following table shows the compliance condition for reference.

Table 1. Condition for the compliance

Model	Cat.	Carrier f	Motor cable
1-ph. 200V class	C2	2kHz	20m (Shielded)
3-ph. 200V class	C3	2kHz	20m (Shielded)
3-ph. 400V class	C3	2kHz	20m (Shielded)

Table 2. Applicable EMC filter

Input class	Inverter model	Filter model (Schaffner)
1-ph. 200V class	NES1-002SB	FS24828-8-07
	NES1-004SB	
	NES1-007SB	FS24828-27-07
	NES1-015SB	
	NES1-022SB	
3-ph. 200V class	NES1-002LB	FS24829-8-07
	NES1-004LB	
	NES1-007LB	
	NES1-015LB	FS24829-16-07
	NES1-022LB	
3-ph. 400V class	NES1-004HB	FS24830-6-07
	NES1-007HB	
	NES1-015HB	FS24830-12-07
	NES1-022HB	
	NES1-040HB	

Important notes

1. Input choke or other equipment is required if necessary to comply with EMC directive from the harmonic distortion point of view (IEC 61000-3-2 and 4).
2. If the motor cable length exceeds 20m, use output choke to avoid unexpected problem due to the leakage current from the motor cable (such as malfunction of the thermal relay, vibration of the motor, etc..).
3. As user you must ensure that the HF (high frequency) impedance between adjustable frequency inverter, filter, and ground is as small as possible.
 - Ensure that the connections are metallic and have the largest possible contact areas (zinc-plated mounting plates).
4. Avoid conductor loops that act like antennas, especially loops that encompass large areas.
 - Avoid unnecessary conductor loops.
 - Avoid parallel arrangement of low-level signal wiring and power-carrying or noise-prone conductors.
5. Use shielded wiring for the motor cable and all analog and digital control lines.
 - Allow the effective shield area of these lines to remain as large as possible; i.e., do not strip away the shield (screen) further away from the cable end than absolutely necessary.
 - With integrated systems (for example, when the adjustable frequency inverter is communicating with some type of supervisory controller or host computer in the same control cabinet and they are connected at the same ground + PE-potential), connect the shields of the control lines to ground + PE (protective earth) at both ends. With distributed systems (for example the communicating supervisory controller or host computer is not in the same control cabinet and there is a distance between the systems), we recommend connecting the shield of the control lines only at the end connecting to the adjustable frequency inverter. If possible, route the other end of the control lines directly to the cable entry section of the supervisory controller or host computer. The shield conductor of the motor cables always must be connected to ground + PE at both ends.
 - To achieve a large area contact between shield and ground + PE-potential, use a PG screw with a metallic shell, or use a metallic mounting clip.
 - Use only cable with braided, tinned copper mesh shield (type "CY") with 85% coverage.
 - The shielding continuity should not be broken at any point in the cable. If the use of reactors, contactors, terminals, or safety switches in the motor output is necessary, the unshielded section should be kept as short as possible.
 - Some motors have a rubber gasket between terminal box and motor housing. Very often, the terminal boxes, and particularly the threads for the metal PG screw connections, are painted. Make sure there is always a good metallic connection between the shielding of the motor cable, the metal PG screw connection, the terminal box, and the motor housing. If necessary, carefully remove paint between conducting surfaces.
6. Take measures to minimize interference that is frequently coupled in through installation cables.
 - Separate interfering cables with 0.25m minimum from cables susceptible to interference. A particularly critical point is laying parallel cables over longer distances. If two cables intersect (one crosses over the other), the interference is smallest if they intersect at an angle of 90°. Cables susceptible to interference should therefore only intersect motor cables, intermediate circuit cables, or the wiring of a rheostat at right angles and never be laid parallel to them over longer distances.

7. Minimize the distance between an interference source and an interference sink (interference-threatened device), thereby decreasing the effect of the emitted interference on the interference sink.
 - You should use only interference-free devices and maintain a minimum distance of 0.25 m from the adjustable frequency inverter.
8. Follow safety measures in the filter installation.
 - If using external EMC filter, ensure that the ground terminal (PE) of the filter is properly connected to the ground terminal of the adjustable frequency inverter. An HF ground connection via metal contact between the housings of the filter and the adjustable frequency inverter, or solely via cable shield, is not permitted as a protective conductor connection. The filter must be solidly and permanently connected with the ground potential so as to preclude the danger of electric shock upon touching the filter if a fault occurs.

To achieve a protective ground connection for the filter:

- Ground the filter with a conductor of at least 10 mm² cross-sectional area.
- Connect a second grounding conductor, using a separate grounding terminal parallel to the protective conductor. (The cross section of each single protective conductor terminal must be sized for the required nominal load.)

Installation for NE-S1 series (example of SB models)

Model LB (3-ph. 200V class) and HB(3-ph. 400V class) are the same concept for the installation.

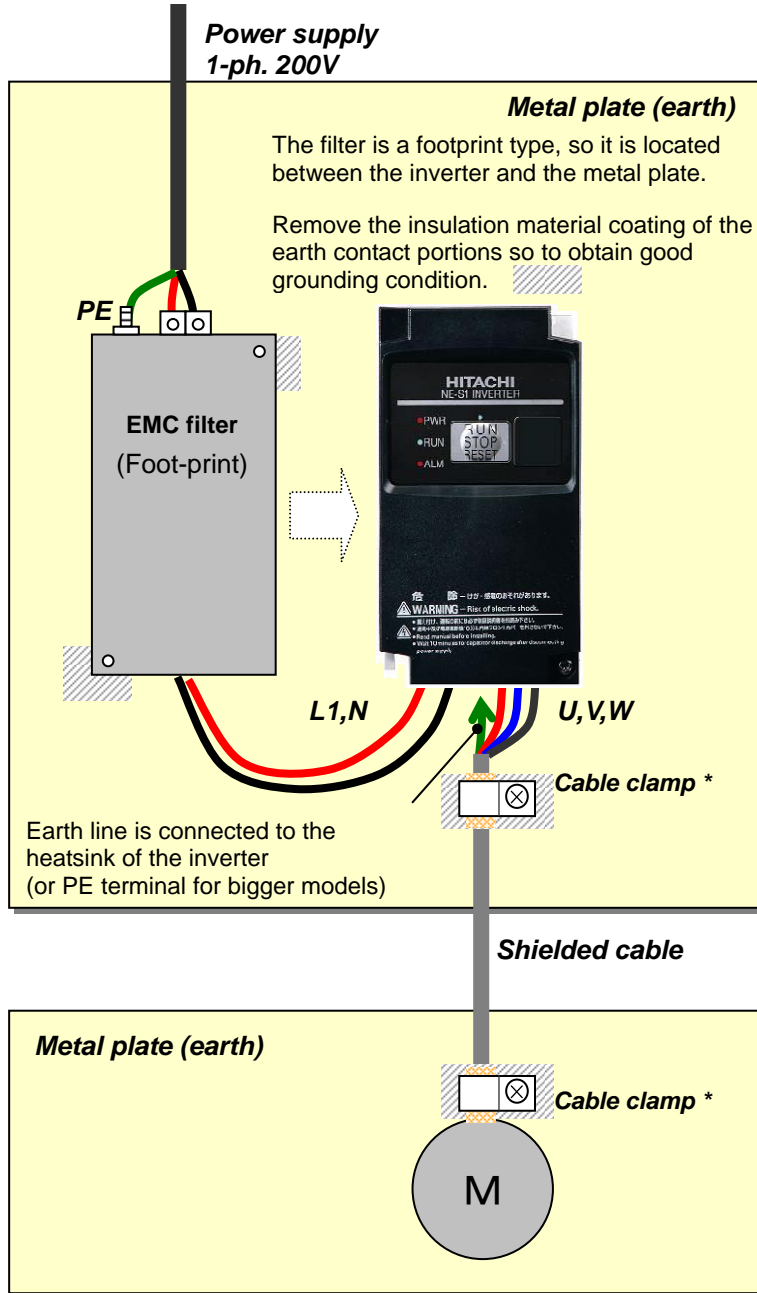

*) Both earth portions of the shielded cable must be connected to the earth point by cable clamps. Input choke or equipment to reduce harmonic current is necessary for CE marking (IEC 61000-3-2 and IEC61000-3-4) from the harmonic current point of view, even conducted emission and radiated emission passed without the input choke.

Hitachi EMC Recommendations



- This equipment should be installed, adjusted, and serviced by qualified personal familiar with construction and operation of the equipment and the hazards involved. Failure to observe this precaution could result in bodily injury.

Use the following checklist to ensure the inverter is within proper operating ranges and conditions.

1. The power supply to NE-S1 inverters must meet these specifications:
 - Voltage fluctuation $\pm 10\%$ or less
 - Voltage imbalance $\pm 3\%$ or less
 - Frequency variation $\pm 4\%$ or less
 - Voltage distortion THD = 10% or less
2. Installation measure:
 - Use a filter designed for NE-S1 inverter. Refer to the instruction of the applicable external EMC filter.
3. Wiring:
 - Shielded wire (screened cable) is required for motor wiring, and the length must be 20 meter or less.
 - If the motor cable length exceeds the value shown above, use output choke to avoid unexpected problem due to the leakage current from the motor cable.
 - The carrier frequency setting must be 2 kHz to satisfy EMC requirements.
 - Separate the power input and motor wiring from the signal/process circuit wiring.
4. Environmental conditions—when using a filter, follow these guidelines:
 - Ambient temperature: -10 to 50 °C
(Derating is required when the ambient temperature exceeds 40 °C)
 - Humidity: 20 to 90% RH (non-condensing)
 - Vibration: 5.9 m/sec² (0.6 G) 10 ~ 55Hz
 - Location: 1000 meters or less altitude, indoors (no corrosive gas or dust)

Chapter 1 Safety Instructions

1.3 Precautions Concerning Compliance with UL and cUL Standards

(Standard to comply with : UL508C,CSA C22.2 No.14-05)

Wiring diagram of inverter

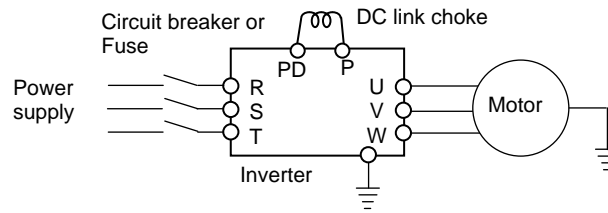

- Maximum surrounding air temperature rating of 50°C.
- Solid State motor overload protection reacts with max. 150 % of FLA.
- Suitable for use on a circuit capable of delivering not more than 100,000 rms Symmetrical Amperes, 240 Volts Maximum. For models 200V class.
Suitable for use on a circuit capable of delivering not more than 100,000 rms Symmetrical Amperes, 480 Volts Maximum. For models 400V class.
- Drive has no provision for motor over temperature protection.
- When protected by J, CC, G or T Class Fuses. or When protected by a circuit breaker having an interrupting rating not less than 100,000 rms symmetrical amperes, 240 Volts maximum. For models 200V class.
When Protected by J, CC, G or T Class Fuses. For models 400V class.
- Integral solid state short circuit protection does not provide branch circuit protection. Branch circuit protection must be provided in accordance with the National Electrical Code and any additional local codes.
- Install device in pollution degree 2 environment
- Branch circuit short circuit protection can use fuse or circuit breaker only. For models 200V class..
Branch circuit short circuit protection can use fuse only. For models 400V class..
- Use 60/75°C CU wire only.
- Tightening torque and wire range as shown in the table below.

Model No.	Required Torque (N.m)	Wire Range(AWG)
NES1-002S,004S	0.8~1.0	16~14
NES1-007S	1.8	14~12
NES1-015S	1.8	12~10
NES1-022S	1.8	10
NES1-002L,004L,007L	0.8~1.0	16~14
NES1-015L	1.8	14
NES1-022L	1.8	12
NES1-004H,007H,015H	1.8	16
NES1-022H,040H	1.8	14

- Distribution fuse and circuit breaker size marking is included in the manual to indicate that the unit shall be connected with a Listed Cartridge Nonrenewable fuse or Inverse time circuit breaker, rated 600 VAC with the current ratings as shown in the table below:

Model No.	Fuse		Circuit Breaker	
	Type	Maximum Rating	Type	Maximum Rating
NES1-002S,004S	Class J, CC, G or T	10 A	Inverse Time	15 A
NES1-007S		20 A		30 A
NES1-015S,022S		30 A		
NES1-002L*,004L*	Class J, CC, G or T	10 A	Inverse Time	15 A
NES1-004L*		15 A		
NES1-007L*,015L		20 A		20 A
NES1-022L				
NES1-004H,007H,015H,022H,040H	Class J, CC, G or T	15A	-	-

* In case of using Circuit Breaker, an additional 5 A external protector is needed.

Chapter 2 Inspection of the Purchased Product

This chapter describes the inspection of the purchased product, the product warranty.

2.1	Inspection of the Purchased Product	2 - 1
2.2	Method of Inquiry and Product Warranty	2 - 2

2.1 Inspection of the Purchased Product

(A) Inspecting the product

Please check the followings after unpacking.

Please contact your supplier or local Hitachi Distributor

if there are any problems like below on the product.

- (1) Any damage during transportation?
- (2) Basic manual (English and Japanese) are packed together with the product?
- (3) The product is the one you ordered.
(check with the specification label)

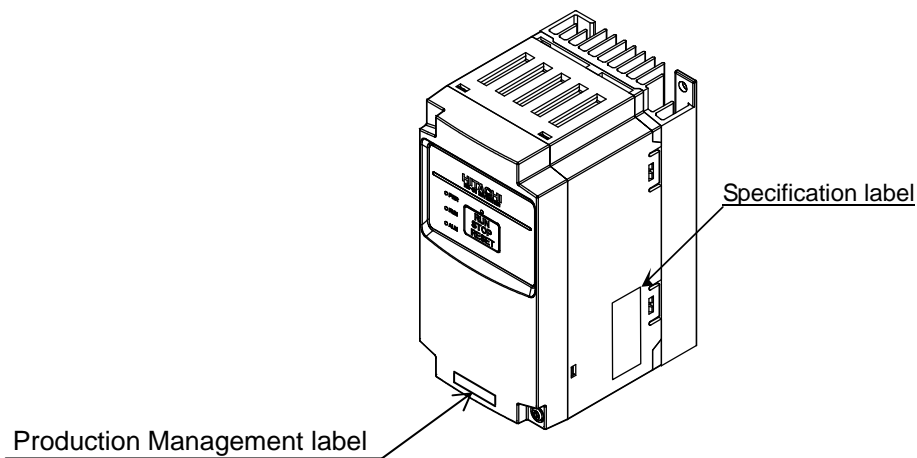

Model name (NES1-002SB example) “*” Restricted Distribution C : China E : Europe None : Other (Standard)																															
<table border="1" style="width: 100%; border-collapse: collapse;"> <tr> <td style="width: 20%; text-align: center;">Input</td> <td style="text-align: center;">Freq. Voltage Phase Current</td> </tr> </table>	Input	Freq. Voltage Phase Current	<table border="1" style="width: 100%; border-collapse: collapse;"> <tr> <td colspan="4" style="text-align: center;">HITACHI INVERTER</td> </tr> <tr> <td colspan="4">Model: NES1-002SB*</td> </tr> <tr> <td style="text-align: center;">Input</td> <td style="text-align: center;">:50Hz, 60Hz</td> <td style="text-align: center;">200-240 V 1Ph</td> <td style="text-align: center;">3.1 A</td> </tr> <tr> <td></td> <td style="text-align: center;">50Hz, 60Hz</td> <td style="text-align: center;">V 3Ph</td> <td style="text-align: center;">A</td> </tr> <tr> <td style="text-align: center;">Output</td> <td style="text-align: center;">:0.5-400Hz</td> <td style="text-align: center;">200-240 V 3Ph</td> <td style="text-align: center;">1.4 A</td> </tr> <tr> <td colspan="2" style="text-align: center;">MFG No. 2616200716000001</td> <td colspan="2" style="text-align: center;">Date:1206</td> </tr> <tr> <td colspan="2" style="text-align: center;">Hitachi Industrial Equipment Systems Co., Ltd.</td> <td style="text-align: center;">W</td> <td style="text-align: center;">NE18158-001</td> </tr> </table>	HITACHI INVERTER				Model: NES1-002SB*				Input	:50Hz, 60Hz	200-240 V 1Ph	3.1 A		50Hz, 60Hz	V 3Ph	A	Output	:0.5-400Hz	200-240 V 3Ph	1.4 A	MFG No. 2616200716000001		Date:1206		Hitachi Industrial Equipment Systems Co., Ltd.		W	NE18158-001
Input	Freq. Voltage Phase Current																														
HITACHI INVERTER																															
Model: NES1-002SB*																															
Input	:50Hz, 60Hz	200-240 V 1Ph	3.1 A																												
	50Hz, 60Hz	V 3Ph	A																												
Output	:0.5-400Hz	200-240 V 3Ph	1.4 A																												
MFG No. 2616200716000001		Date:1206																													
Hitachi Industrial Equipment Systems Co., Ltd.		W	NE18158-001																												
<table border="1" style="width: 100%; border-collapse: collapse;"> <tr> <td style="width: 20%; text-align: center;">Output</td> <td style="text-align: center;">Freq. Volt. & phase Current</td> </tr> </table>	Output	Freq. Volt. & phase Current																													
Output	Freq. Volt. & phase Current																														
<table border="1" style="width: 100%; border-collapse: collapse;"> <tr> <td style="width: 100%; text-align: center;">Manufacturing number</td> </tr> </table>	Manufacturing number																														
Manufacturing number																															

Example of the specification label

Chapter 2 Inspection of the Purchased Product

2.2 Method of Inquiry and Product Warranty

(A) Method of inquiry

In case of contacting to the store you bought the product or Hitachi, please inform the following information.

- (1) Model name of the inverter
- (2) Manufacturing number (MFG No.)
- (3) When you bought the product
- (4) Contents of your inquiry
- Damaged portion and condition, and else.

(B) Product warranty

The product will be warranted for one year after the date of purchase.

Even within the warranty period, repair of a product fault will not be covered by the warranty (but the repair will be at your own cost) if:

- (1) the fault has resulted from incorrect usage not conforming to the instructions given in this Instruction Manual or the repair or modification of the product carried out by an unqualified person,
- (2) the fault has resulted from a cause not attributable to the delivered product,
- (3) the fault has resulted from use beyond the limits of the product specifications, or
- (4) the fault has resulted from disaster or other unavoidable events.

The warranty will only apply to the delivered inverter and excludes all damage to other equipment and facilities induced by any fault of the inverter.

Repair at the user's charge

Following the one-year warranty period, any examination and repair of the product will be accepted at your charge. Even during the warranty period, examination and repairs of faults, subject to the above scope of the warranty disclaimer, will be available at charge.

To request a repair at your charge, contact your supplier or local Hitachi Distributor.

The Hitachi Distributors are listed on the back cover of this Instruction Manual.

(C) Warranty Terms

The warranty period under normal installation and handling conditions shall be two (2) years from the date of manufacture ("DATE" on product nameplate), or one (1) year from the date of installation, whichever occurs first. The warranty shall cover the repair or replacement, at Hitachi's sole discretion, of ONLY the inverter that was installed.

- (1) Service in the following cases, even within the warranty period, shall be charged to the purchaser:
 - a. Malfunction or damage caused by mis-operation or modification or improper repair
 - b. Malfunction or damage caused by a drop after purchase and transportation
 - c. Malfunction or damage caused by fire, earthquake, flood, lightning, abnormal input voltage, contamination, or other natural disasters
- (2) When service is required for the product at your work site, all expenses associated with field repair shall be charged to the purchaser.
- (3) Always keep this QRG handy; please do not lose it. Please contact your Hitachi distributor to purchase replacement or additional QRG.

Chapter 3 Exterior Views



This chapter describes the exterior views and the names of parts.

3.1	Exterior Views and Names of Parts	3 - 1
3.2	Name of each portion (removing the front cover)	3 - 2

3.1 Exterior Views and Names of Parts

The figure below shows an exterior view of the inverter
 - model : NES1 – 002*,004*SB/LB , 007*LB

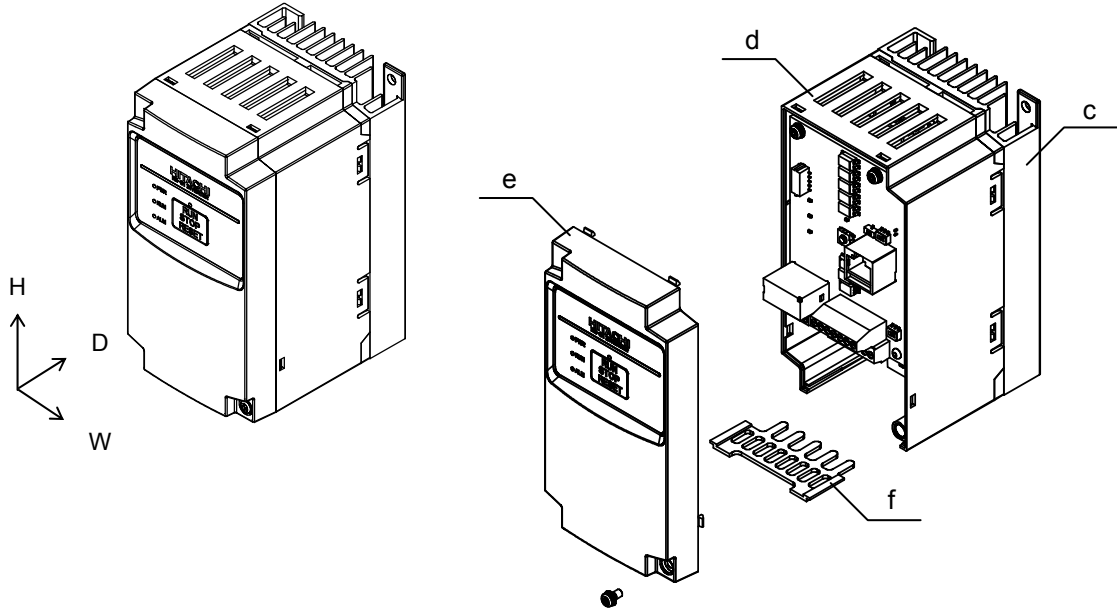

- model : NES1 – 007*SB , 015,022SB , 004*,007,015,022HB,040HB

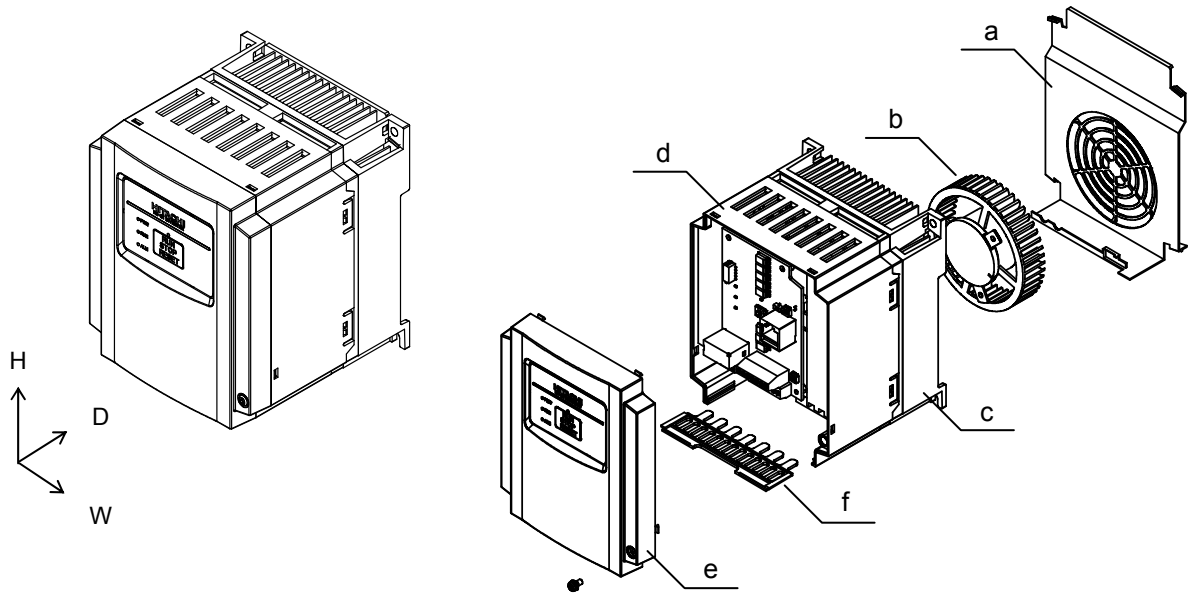

*)002-007SB/LB and 004HB : without Cooling Fan

- a) Cooling Fan Cover
- b) Cooling Fan
- c) Heat sink
- d) Case
- e) Front Cover
- f) Backing plate

3.2 Name of each portion (removing the front cover) Note1)

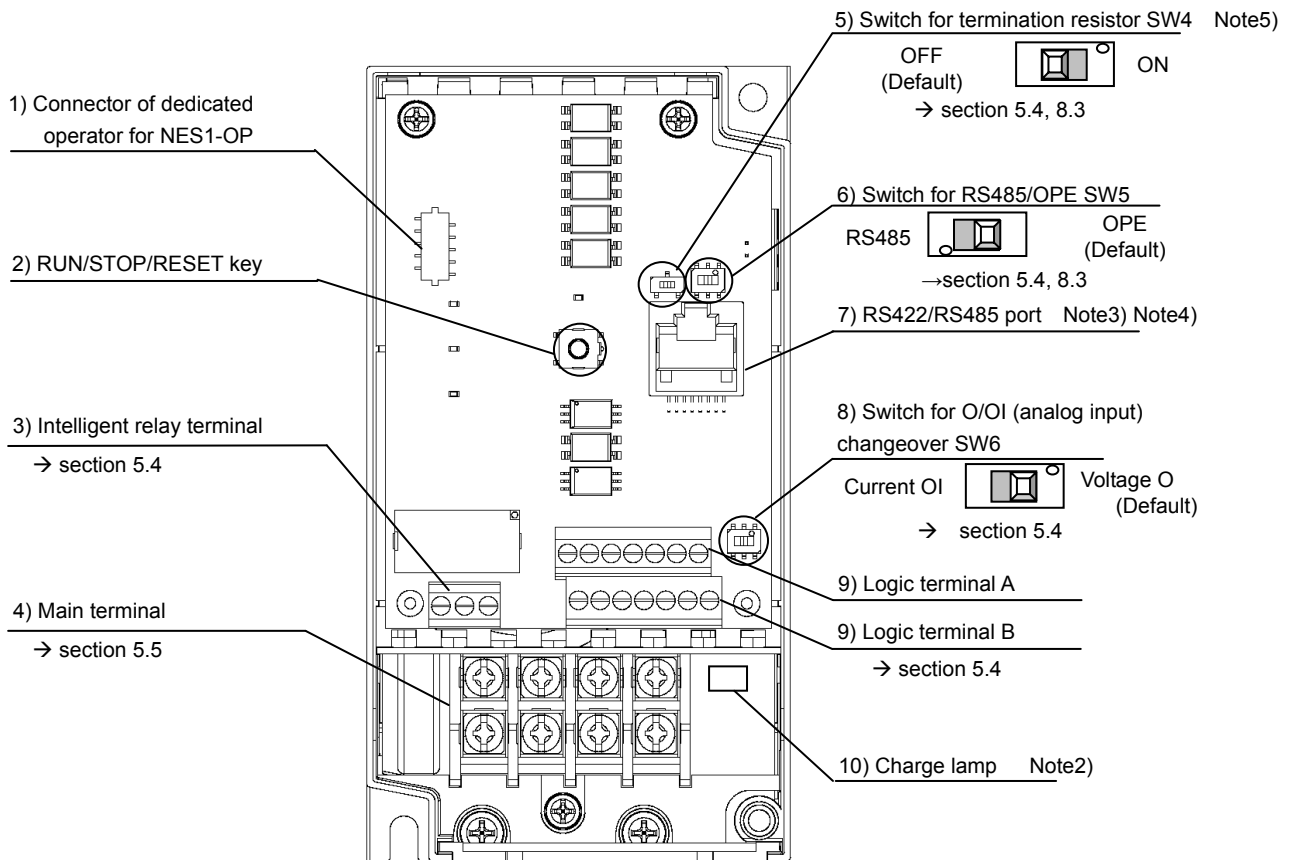

Name	Description
1) Connector of dedicated operator for NES1-OP	Dedicated operator for NE-S1 (NES1-OP) can be connected.
2) RUN/STOP/RESET key	Push key for run, stop and reset operation.
3) Intelligent relay terminal	Output terminal for intelligent relay (1c contact).
4) Main terminal	For connecting power supply, motor output and DC reactor.
5) Switch for termination resistor	Changeover for integrated resistor (100Ω) for RS485. Integrated resistor of 100Ω is connected when turning ON.
6) Switch for RS485/OPE	Changeover switch for RS422/RS485.
7) RS422/RS485 port	Connector for RS485 or external operator and PC software (RJ45 jack)
8) Switch for O/OI (analog input) changeover	Voltage input (O) or current input (OI) can be selected.
9) Logic terminal A,B	Terminal for connecting input/output signals (digital/analog) for the inverter control.
10) Charge lamp	Turns ON when the internal DC bus voltage is 45V or more. In case of wiring, maintenance or else, be sure to check that this lamp is turned OFF after waiting 10 minutes of power OFF.

Note 1) Refer to section 6.5 How To Operate the Inverter.

Note 2) Position of "10) charge lamp" depends on the model. Refer to page 2-11 for the details.

Note 3) Pay attention when operating by PC via "7)RS422/RS485 port", because the operation can also be done from the panel of the inverter.

Note 4) Be sure to turn power OFF when connecting or disconnecting the operator such as OPE-SRmini,OPE-S,WOP to the "7) RS422/RS485 port".

Note 5) When communication becomes unstable, Please do not use the termination resistor of the inverter. Please use a termination resistor suitable for your environment.

Chapter 4 Installation

This chapter describes how to install the inverter.

4.1	Precautions for installation	4 - 1
-----	------------------------------------	-------

4.1 Precautions for installation



- Install the inverter on a non-flammable surface, e.g., metal. Otherwise, you run the risk of fire.
- Do not place flammable materials near the installed inverter. Otherwise, you run the risk of fire.
- When carrying the inverter, do not hold its top cover. Otherwise, you run the risk of injury by dropping the inverter.
- Prevent foreign matter (e.g., cut pieces of wire, sputtering welding materials, iron chips, wire, and dust) from entering the inverter. Otherwise, you run the risk of fire.
- Install the inverter on a structure able to bear the weight specified in the Instruction Manual. Otherwise, you run the risk of injury due to the inverter falling.
- Install the inverter on a vertical wall that is free of vibrations. Otherwise, you run the risk of injury due to the inverter falling.
- Do not install and operate the inverter if it is damaged or its parts are missing. Otherwise, you run the risk of injury.
- Install the inverter in a well-ventilated indoor site not exposed to direct sunlight. Avoid places where the inverter is exposed to high temperature, high humidity, condensation, dust, explosive gases, corrosive gases, flammable gases, grinding fluid mist, or salt water. Otherwise, you run the risk of fire.
- The inverter is precision equipment. Do not allow it to fall or be subject to high impacts, step on it, or place a heavy load on it. Doing so may cause the inverter to fail.
- When you touch the inverter, you must take care at static electricity. Doing so may cause the inverter to fail.

Chapter 4 Installation

(1) Caution during transportation

Please pay attention when carrying the product because it is covered by plastic case. Especially, do not put pressure onto the front cover and terminal cover. Otherwise there is a risk of falling down the product. Please do not use products having damage, and/or lacking components.

(2) Ensure Adequate Ventilation

To summarize the caution messages – you will need to find a solid, non-flammable, vertical surface that is in a relatively clean and dry environment. In order to ensure enough room for air circulation around the inverter to aid in cooling, it is recommended to maintain the specified clearance and the inverter specified in the below diagram.

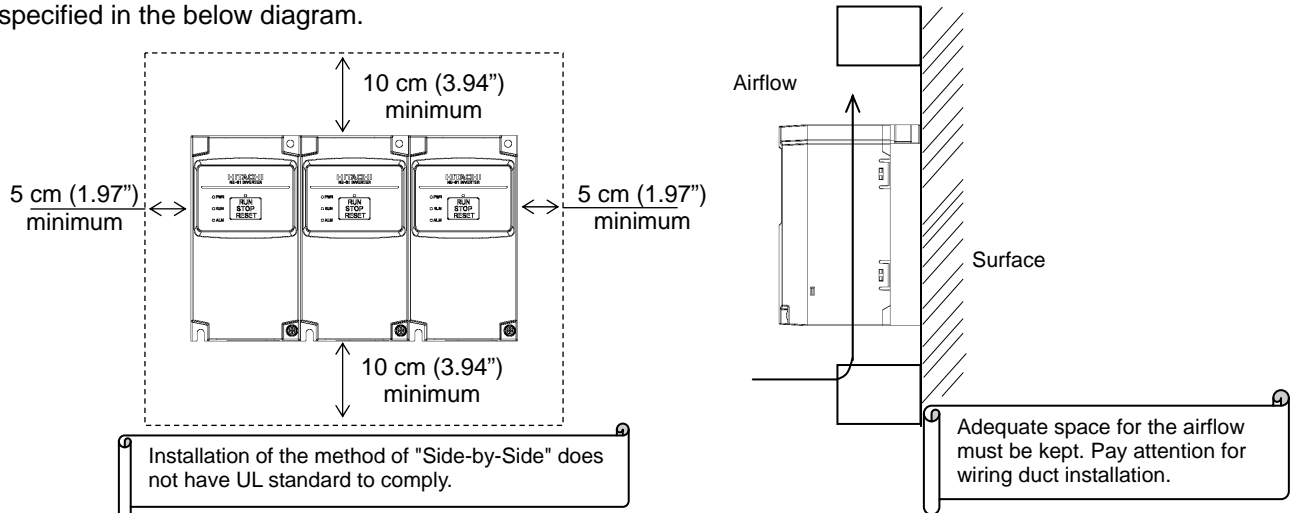

(3) Caution for ambient temperature

Set ambient temperature at installation site within the standard specification range (-10~50°C). Measure ambient temperature at the place apart by 5cm from the bottom center of inverter main body and confirm that it is within the allowable temperature range.

Using the inverter at higher temperature than allowable temperature may result in shortening of lifetime of inverter (especially of electrolytic capacitor). Derating curve is shown on section 12.3.

(4) Do not install the inverter in such places as high temperature, high humidity, or easy to condensate.

Use the inverter within the allowable humidity range (20~90%RH) described in standard specifications.

Especially, please use it in place where no dew condensation occurs. If dew condensation occurs and beading is generated inside the inverter, electronic parts are short-circuited each other to cause a failure. Also, please avoid installing it in a location which receives direct sunlight.

(5) Caution for installation environment

Please avoid installing the inverter in such places where dust, corrosive gas, explosive gas, flammable gas, mist of grinding fluid, or salt pollution, etc. exists.

Invasion of dust, dirt etc. into the inverter may cause a failure. So, when you use it in dusty place by necessity, please devise a countermeasure such as putting it into a closed type chassis.

CAUTION

- Reduction of the carrier frequency or using bigger kW model is required if depends on the load or ambient.

WARNING

- Do not open the front cover during live parts inside.

(6)Cautions for installation direction

Surface of the installation must be no vibration, and should be capable of holding the weight of the product. And the product must be fixed to the surface with a proper screws with vertical direction.

Be sure to screw using all the screw holes for the installation.

(002L/SB,004L/SB,007LB : 2 positions, 004HB,007S/HB,015L/S/HB,022L/S/HB : 4 positions)

There is a risk of performance failure, and/or breakdown when the product is not installed vertical direction.

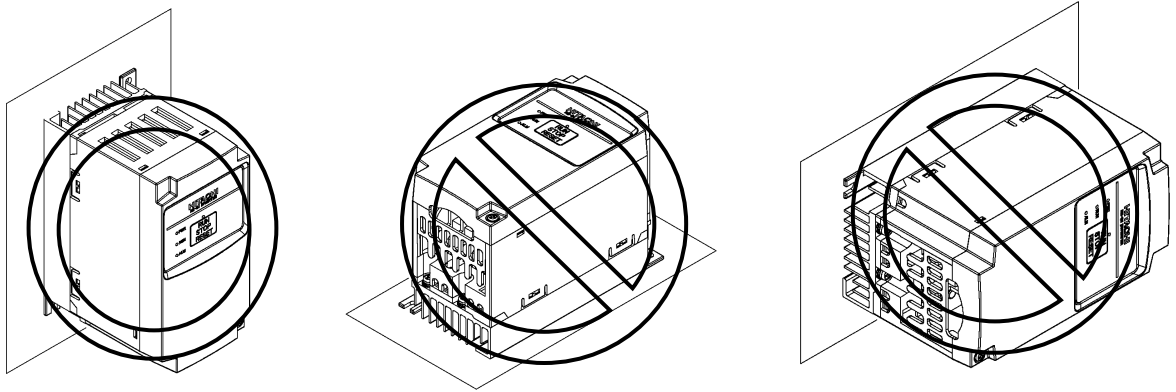

(7)Cautions for installation into the cabinet

Please pay attention to the location of the ventilation holes of the inverter and the cabinet, in case of side-by-side installation and using ventilation fan.

cooling performance of the inverter highly depends on the location of the holes. Please pay high attention to the ambient temperature of the inverter to be less than the specified value.

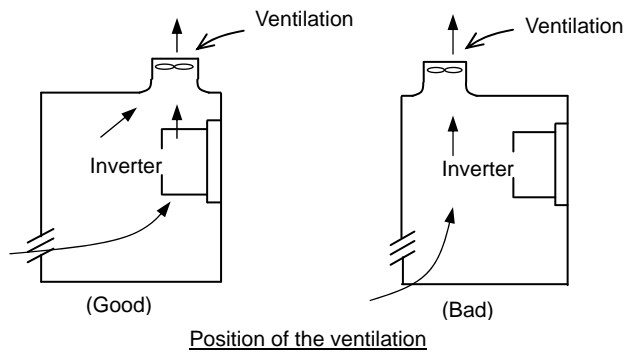

(8)Watt Loss

1-ph./3-ph. 200V class

Model name	002S/L	004S/L	007S/L	015S/L	022S/L
Watt Loss (100% load)(W)	22	30	48	79	104
Efficiency at rated load(%)	90	93	94	95	95.5

3-ph. 400V class

Model name	004H	007H	015H	022H	040H
Watt Loss (100% load)(W)	35	56	96	116	167
Efficiency at rated load(%)	92	93	94	95	96

Chapter 5 Wiring

This chapter describes the wiring of main circuit and control signal terminals.

5.1	Precautions for Wiring	5 - 1
5.2	How to attach and remove the front cover.....	5 - 2
5.3	How to attach the Exclusive operator (NES1-OP)	5 - 3
5.4	Wiring and terminal description	5 - 4
5.5	Mains wiring.....	5 - 7
5.6	Wiring of the control circuit	5 - 12
5.7	Connection with the programmable controller (PLC)	5 - 14
5.8	Notes on using multiple inverters	5 - 15

5.1 Precautions for Wiring

WARNING

- In order to prevent damage caused by static electricity, Please remove the static electricity of the body touch the nearby metal before touching this product.
- Be sure to ground the inverter. Otherwise, you run the risk of electric shock or fire.
- Commit wiring work to a qualified electrician. Otherwise, you run the risk of electric shock or fire.
- Before wiring, make sure that the power supply is off. Otherwise, you run the risk of electric shock or fire.
- Perform wiring only after installing the inverter. Otherwise, you run the risk of electric shock or injury.
- The inverter must be powered OFF before you change any of the slide switch settings. Otherwise, you run the risk of electric shock or injury.

CAUTION

- Make sure that the voltage of AC power supply matches the rated voltage of your inverter. Otherwise, you run the risk of injury or fire.
- Do not input single-phase power into the 3-phase inverter. Otherwise, you run the risk of fire.
- Do not connect AC power supply to any of the output terminals (U, V, and W). Otherwise, you run the risk of injury or fire.
- NE-S1 series inverter do not have terminals for braking resistor. Do not connect the resistor. Otherwise there is a risk of fire.
- Connect an earth-leakage breaker to the power input circuit. Otherwise, you run the risk of fire.
- Use only the power cables, earth-leakage breaker, and magnetic contactors that have the specified capacity (ratings). Otherwise, you run the risk of fire.
- Do not use the magnetic contactor installed on the primary and secondary sides of the inverter to stop its operation.
- Tighten each screw to the specified torque. No screws must be left loose. Otherwise, you run the risk of fire.
- Before operating slide switch in the inverter, be sure to turn off the power supply. Otherwise, you run the risk of electric shock and injury.
- Please make sure that earth screw was tighten completely in advance.
- First, check the tightening the screws of output terminal (U, V and W), and then tighten the screws of input terminal (R, S and T).
- Factory default of C036 is "b contact(NC)". In the event that the initialization, C036 will be the "b contact(NC)". If you wish to use as a replacement for the conventional model of this inverter, such as in the case of built-in system use, please first check the configuration of C036. And, you must conform to the peripheral circuit logic. There is a risk of system down by logical inconsistency contact.

5.2 How to attach and remove the front cover

(1) How to remove

1) Loosen up the screw

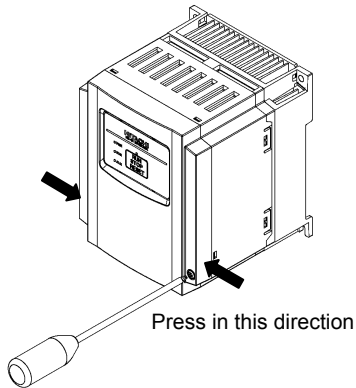

2) remove the cover by pressing the bottom side of the cover to the direction shown below.

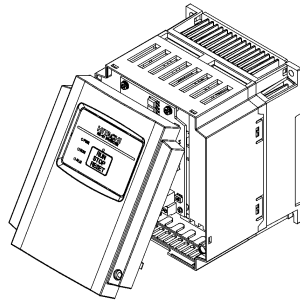

3) Move the wiring plate like shown below in case of wiring.

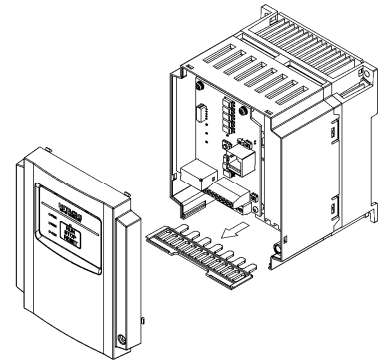

Screw for fixing the front cover is located at right-bottom side

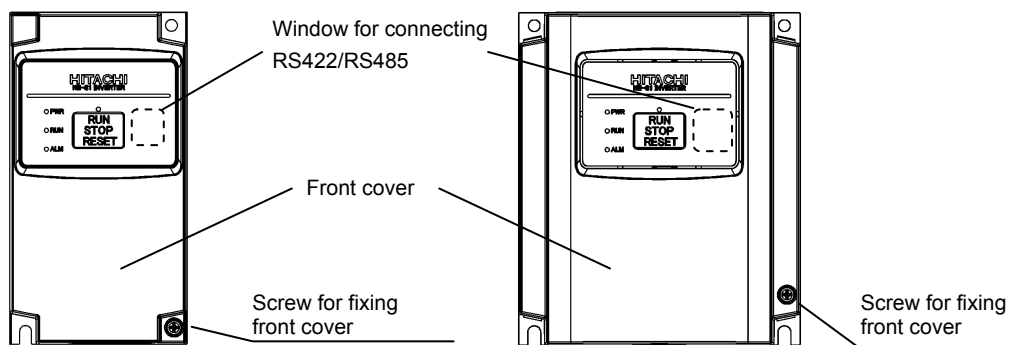

(2) It is necessary to make window on the front cover when using remote operator

(OPE-S/SR/SBK/SRmini, WOP), Modbus-RTU, or PC software (ProDriveNext). See above for the position of the window.

- Be sure to make window after removing the front cover.
- There are cutouts at the window, so it can be removed easily by pressing up side and bottom side of the window alternatively.
- The window cannot be restored if it is once opened. Please use commercially supplied RJ45 connector cap or the like if necessary.

(3) How to attach

- Press the front cover to the main body until there is a click sound.
- Do not tighten the screw too much.

5.3 How to attach the Exclusive operator (NES1-OP)

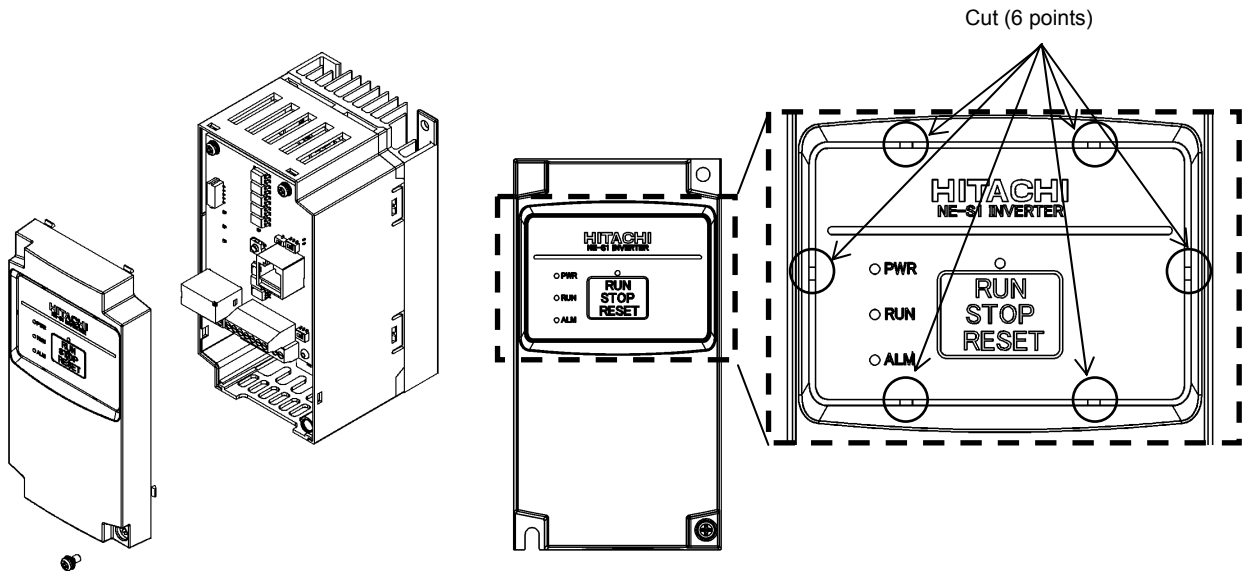

1) Remove the front cover from main body

2) Cut the standard operator panel by in-thin-blade-nipper and take it off.

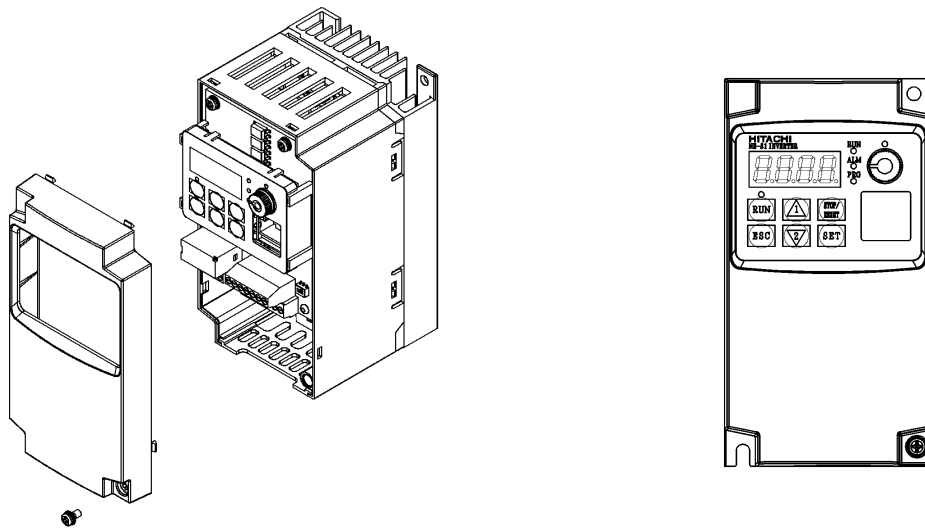

3) The connector of the exclusive operator (NES1-OP) connect to the connector on the circuit board. And attach it to put the circuit board.

4) Attach the front cover.

5) Figure of installation (NES1-OP)

Note) Please set SW4, SW5 on the board, before installation of exclusive operator (NES1-OP).

Chapter 5 Wiring

5.4 Wiring and terminal description

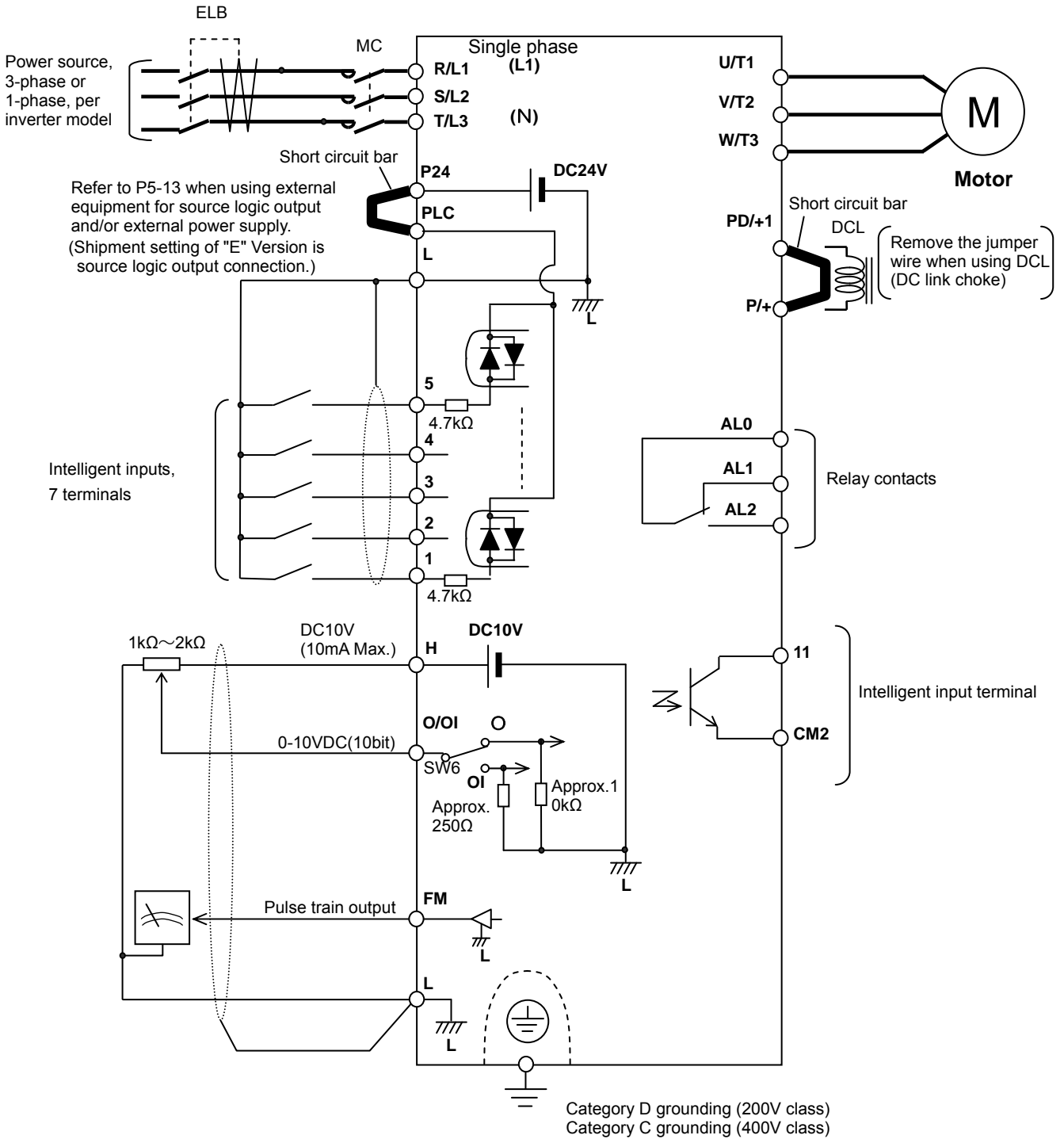

Note 1) Above shows an example of voltage (O) input. Changeover of SW6 must be done in case of current (OI) input.

(1) Mains terminal description

Symbol	Name	Description
R/L1(L1) S/L2 T/L3(N)	Power input terminals	Connect power supply - Use [L1] and [N] terminal in case of 1-ph. 200V power supply
U/T1 V/T2 W/T3	Power output terminals	Connect 3-ph. motor
PD/+1 P/+	DC link choke connection terminal	First, remove the short circuit bar between PD/+1 and P/+ terminal. Then connect optional DC link choke for improving the input harmonics.
G(⊕)	Earth terminal	To make grounding. Be sure to make this grounding to avoid electric shock, and for improving the EMC performance. The terminal is located on the heatsink.

(2) Control terminal description

Category	Symbol	Name	Description	Electrical characteristics	
Analog	Power supply	L	Common for input signals	Common for internal control power supply, digital inputs/outputs, analog inputs/outputs	
		H	Power supply for freq.set	DC10V power supply. Used with variable resistor for O input.	Max.10mA withdraw
	Freq. set	O/OI	Analog voltage (Use SW6 for changeover)	Frequency set via DC0~10V input	Input impedance=apprx.10kΩ Allowable range; -0.3~+12VDC
			Analog current (Use SW6 for changeover)	Frequency set via 0~20mA Parameter adjustment should be done in case of 4~20mA	Input impedance=apprx.250Ω Allowable range; 0~20mA
Digital	Power supply	L	Common for dig. Inputs	Common for internal control power supply, digital inputs, analog inputs/outputs (Sink terminal)	
		P24	Power supply for dig. inputs	DC24V power supply for dry contact input. (Common terminal in case of source logic) note	Max.100mA output
		PLC	Power supply terminal for input terminals	Sink logic : connected to P24 Source logic : connected to L Remove the jumper wire when using external power supply for controlling the dry contact inputs.	

note)The voltage of P24 changes like the chart below by a load electric current. In the case of use, please be careful about external equipment. (ext-operator:OPE-S/SR/SBK/SRmini)
As for this chart application, it is just for December, 2012 production.
Thereafter, all models become the curve to show in 015,022L/SB.

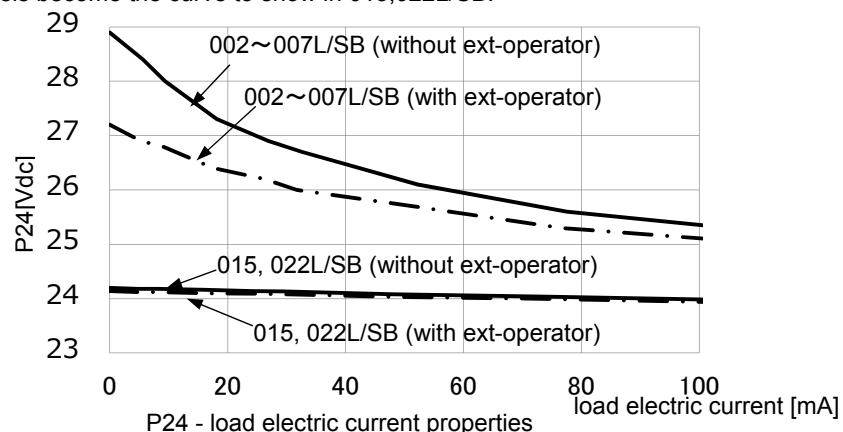

Chapter 5 Wiring

Category		Symbol	Name	Description	Electrical characteristics	
Digital	Input	Contact	5	Intelligent input terminals	5 functions from 35 functions can be assigned to terminal 1 to 5. Sink or source logic can be selected.	Voltage between each input and PLC - V(ON) = min.18V - V(OFF) = MAX.3V - Max. allowable voltage = 27VDC - Load current 5mA (24V)
			4			
	3					
	2					
	1					
Output	Open-collector	11	Intelligent output terminals	One function from 28 functions can be assigned.	Open collector output Between 11 and CM2 - Voltage drop during ON=4V or less - Max. allowable voltage = 27V - Max allowable current = 50mA	
		CM2	Common for intelligent output terminals	Common for the terminal 11.	Max. allowable current = 100mA	
	Relay	AL0 AL1 AL2	Intelligent relay outputs	One function from 28 functions can be assigned. (1-c contact)	Max. contact capacity AL1-AL0 : AC250V, 2A(resistive),0.2A(inductive) AL2-AL0 : AC250V, 1A(resistive),0.2A(inductive) Min. contact capacity AC100V, 10mA DC5V, 100mA	
	Pulse train	FM	Digital pulse train output	Pulse frequency MAX.3.6kHz	Pulse voltage : DC0/10V output Max. allowable current : 2mA	

(3) Changeover switch description

Refer to section 3.2 for the location of the switches.

CAUTION

- Adjustment of the switch must be done during power off. Otherwise there is a risk of electric shock.
- Power ON must be done after closing the front cover. Do not open the front cover during power up, or when there is a remaining voltage. There is a risk of electric shock.

Symbol	Name	Description	
SW4	Termination resistor changeover switch	Select able/disable of the termination resistor of RS485 port (RJ45)	
		OFF (left side)	Termination resistor (100Ω) Disable (Default)
		ON (right side)	Termination resistor (100Ω) Able
SW5	RS485/OPE(RS422) changeover switch	Select depending on the options and communication method, connected to RS422/RS485 port.	
		OFF (right side)	For operator (OPE-S/SR/SBK/SRmini), ProDriveNext (Default)
		ON (left side)	For RS485 communication (Modbus-RTU)
SW6	Analog input (O/OI) changeover switch	OFF (left side)	Current input (0~20mA) OI
		ON (right side)	Voltage input (0~10Vdc) O (Default)

5.5 Mains wiring

(1) Cautions on wiring

Be sure to confirm that the charge lamp is turned OFF before the wiring work.

Once it is powered up, there will be a remaining voltage at the DC bus capacitor for a certain period regardless the motor operation.

Wiring work must be done 10 minutes after the power off, after confirming the safety.

In case the power indication of the operator does not turn ON after power-up, inverter may be damaged. In that case, the inspection must be done after waiting 2 hours or more of the power OFF. Otherwise there is a danger of electric shock and/or injury.

1) Mains input terminals (R/L1,S,T/N)

- Use earth leakage breaker (ELB) for protection between power supply and input terminals (R/L1,S,T/N).
- The ELB is recommended to have bigger capability for the high frequency sensitivity, so to avoid malfunction.

Distance between inverter and motor	Cutoff current of ELB
100m or less	30mA
300m or less	100mA
800m or less	200mA

[Rough indication of earth leakage current] 30mA/km : use CV cable with metallic tube. Leakage current will be approximately 8 times more when using H-IV cable.

Therefore, it is recommended to use one class bigger capability of the ELB. Previously mentioned "leakage current" is based on the RMS value of fundamental wave, excluding harmonic current.

- There is a possibility that the malfunction or failure of the customer's system when the protection circuit of the inverter is activated. Please use magnet contactor to shutoff the inverter power supply.
- Do not turn power ON and OFF by the magnet contactor at the primary side or secondary side of the inverter to start and stop the motor. Use operation command (FW, RV) from the control input terminal in case of using external signal.
- Do not use the 3-ph input type with single phase input (phase loss). Otherwise there is a risk of inverter failure. Single phase input to the 3 phase type inverter will result in a undervoltage, overcurrent, or will result in a damage of the inverter. [DC bus capacitor will be charged even under phase loss and it is dangerous. Refer to "(1) Cautions for wiring" for the wiring.]
- There is a risk of breakdown of the internal converter module, and/or shortening drastically the lifetime of DC bus capacitors due to an increase of the ripple current. Especially, if high reliability is required on the system, use AC reactor between power supply and inverter. And if a thunder is expected, use appropriate lightning protection equipment.
 - Unbalance at the input voltage (3% or more)
 - Impedance of the power supply is 10 times or more, and 500kVA or more
 - Rapid change in voltage is expected

(Example)- 2 or more inverters are connected at the same net with short cable.

 - Inverter is connected in parallel with the thyristor equipment with short cable.
 - Phase advancing capacitor is switching on a same net
- Frequency of the power ON/OFF must be once/3 minutes or longer interval. There is a danger of inverter failure.
- An inverter run by a private power generator may overheat the generator or suffer from a deformed output voltage waveform of the generator. Generally, the generator capacity should be five times that of the inverter (kVA) in a PWM control system or six times greater in a PAM control system.
- In the case of important equipment, to shorten the non-operational time of inverter failure, please provide a backup circuit by commercial power supply or spare inverter.

Chapter 5 Wiring

- In case of commercial power source switching functions, mechanical interlock the MC1 & MC2 contacts with each others is required. Otherwise you may damage the inverter and the danger of injury and/or fire. Please refer to following diagram.

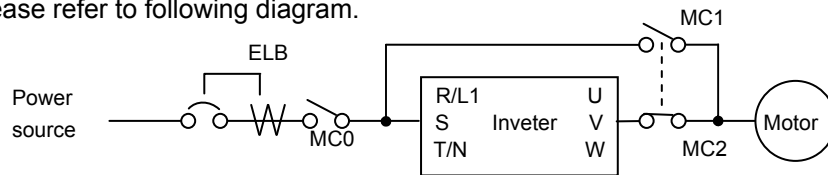

2) Inverter output terminals (U(T1), V(T2), and W(T3))

- Use a cable thicker than the specified applicable cable for the wiring of output terminals to prevent the output voltage between the inverter and motor dropping. Especially at low frequency output, a voltage drop due to cable will cause the motor torque to decrease.
- Do not connect a phase-advanced capacitor or surge absorber on the output side of the inverter. If connected, the inverter may trip or the phase-advanced capacitor or surge absorber may be damaged.
- If the cable length between the inverter and motor exceeds 20 m (especially in the case of 400 V class models), the stray capacitance and inductance of the cable may cause a surge voltage at motor terminals, resulting in a motor burnout. A special filter to suppress the surge voltage is available. If you need this filter, contact your supplier or local Hitachi Distributor.
- When connecting multiple motors to the inverter, connect a thermal relay to the inverter output circuit for each motor.
- The RC rating of the thermal relay must be 1.1 times as high as the rated current of the motor. The thermal relay may go off too early, depending on the cable length. If this occurs, connect an AC reactor to the output of the inverter.

3) DC reactor connection terminals (PD(+1) and P(+))

- Use these terminals to connect the optional DC power factor reactor (DCL). As the factory setting, terminals P(+) and PD(+1) are connected by a jumper. Remove this to connect the DCL.
- The cable length between the inverter and DCL must be 5 m or less.

Remove the jumper only when connecting the DCL.

If the jumper is removed and the DCL is not connected, power is not supplied to the main circuit of the inverter, and the inverter cannot operate.

4) Inverter ground terminal (G ⊕)

- Be sure to ground the inverter and motor to prevent electric shock.
- According to the Electric Apparatus Engineering Regulations, connect 200 V class models to grounding electrodes constructed in compliance with type-D grounding (conventional type-III grounding with ground resistance of 100Ω or less) or the 400 V class models to grounding electrodes constructed in compliance with type-C grounding (conventional special type-III grounding with ground resistance of 10Ω or less).
- Use a grounding cable thicker than the specified applicable cable, and make the ground wiring as short as possible.
- When grounding multiple inverters, avoid a multi-drop connection of the grounding route and formation of a ground loop, otherwise the inverter may malfunction.

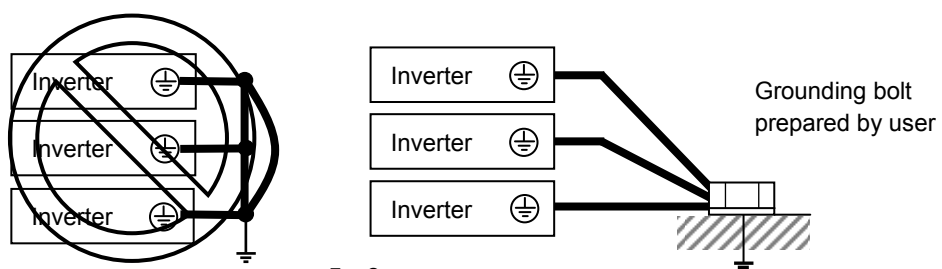

(2) Layout of main circuit terminals

The figures below show the terminal layout on the main circuit terminal block of the inverter.

The main circuit terminal block opens a faceplate and wires it.

Single-phase 200V 0.2 to 0.4kW
 Three-phase 200V 0.2 to 0.75kW

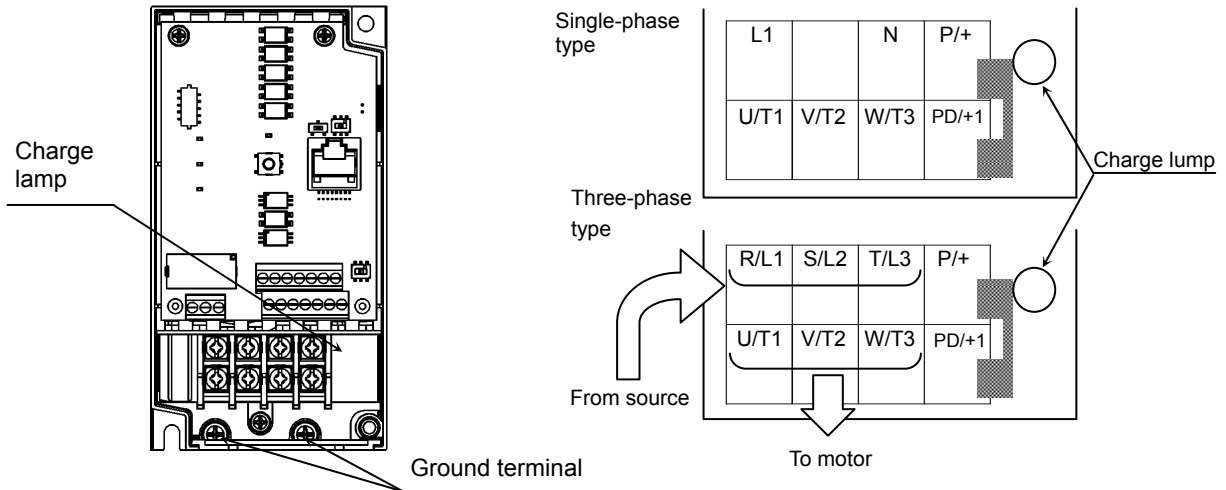

Single-phase 200V 0.75 to 2.2kW
 Three-phase 200V 1.5 , 2.2kW
 Three-phase 400V 0.4 to 4.0kW

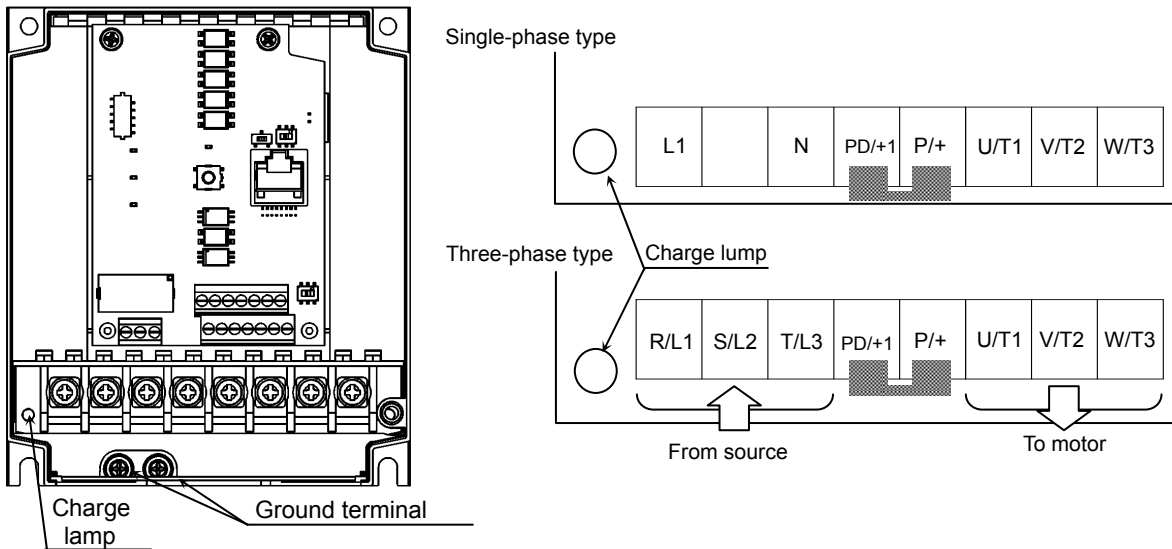

(3) Applicable peripheral equipment

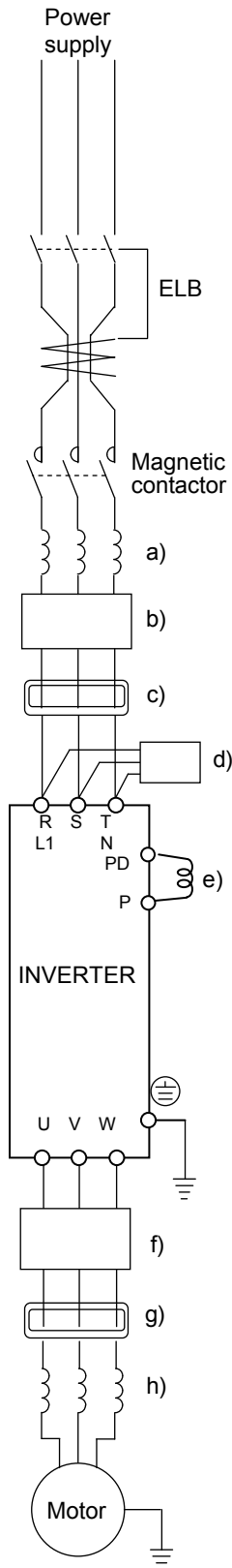

- Note 1: The peripheral equipment described here is applicable when the inverter connects a standard Hitachi 3-phase, 4-pole squirrel-cage motor.
- Note 2: Select breakers that have proper capacity. (Use breakers that comply with inverters.)
- Note 3: Use earth-leakage breakers (ELB) to ensure safety.
- Note 4: Use copper electric wire (HIV cable) of which the maximum allowable temperature of the insulation is 75°C.
- Note 5: If the power line exceeds 20 m, cable that is thicker than the specified applicable cable must be used for the power line.
- Note 6: Use a 0.75 mm² cable to connect the alarm output contact.
- Note 7: Tighten each terminal screw with the specified tightening torque. Loose terminal screws may cause short circuits and fire. Tightening a terminal screw with excessive torque may cause damage to the terminal block or inverter body.
- Note 8: Select an earth-leakage breaker (ELB) of which the rated sensitivity current matches the total length of cables connected between the inverter and power supply and between the inverter and motor. Do not use a high-speed type ELB but use a delayed-type ELB because the high-speed type may malfunction.
- Note 9: When a CV cable is used for wiring through a metal conduit, the average current leakage is 30 mA/km.
- Note 10: When an IV cable, which has a high relative dielectric constant, is used, the leakage current is about eight times as high as the standard cable. Therefore, when using an IV cable, use the ELB of which the rated sensitivity current is eight times as high as that given in the table below. If the total cable length exceeds 100 m, use a CV cable.

Total cable length	Sensitivity current (mA)
100 m or less	30
300 m or less	100
800 m or less	200

- Note 11: If there are any thyristor equipments belonging to the same net, and a possibility that the surge voltage is given to the net, change the connecting order of above a) and b). (Connecting order: Net→ELB→Contactor →Noise filter b)→Input Choke a)→Inverter). Otherwise, there is a danger of damaging inverter and/or fire.

Name	Description
a) Reactor on input side (for harmonic control, power supply coordination, and power factor improvement) (ALI-XXX) Note 11	Use this reactor to control harmonic waves or when the imbalance of power supply voltage is 3% or more, when the power supply capacity is 500 kVA or more, or when the power voltage may change rapidly. This reactor also improves the power factor.
b) Noise filter for inverter (NF-XXX) Note 11	This noise filter reduces the conductive noise that is generated by the inverter and transmitted in cables. Connect this noise filter to the primary side (input side) of the inverter.
c) Radio noise filter (Zero-phase reactor) (ZCL-X)	The inverter may generate radio noise through power supply wiring during operation. Use this noise filter to reduce the radio noise (radiant noise).
d) Radio noise filter on input side (Capacitor filter) (CFI-X)	Use this noise filter to reduce the radiant noise radiated from input cables.
e) DC reactor (DCL-X-XX)	Use this reactor to control the harmonic waves generated by the inverter.
f) Noise filter on the output side (ACF-CX)	Connect this noise filter between the inverter and motor to reduce the radiant noise radiated from cables for the purpose of reducing the electromagnetic interference with radio and television reception and preventing malfunctions of measuring equipment and sensors.
g) Radio noise filter (Zero-phase reactor) (ZCL-XXX)	Use this noise filter to reduce the noise generated on the output side of the inverter. (This noise filter can be used on both the input and output sides.)
h) AC reactor for the output side For reducing vibrations and preventing thermal relay malfunction (ACL-X-XX)	Using the inverter to drive a general-purpose motor may cause larger vibrations of the motor when compared with driving it directly with the commercial power supply. Connect this AC reactor between the inverter and motor to lessen the pulsation of motor. Also, connect this AC reactor between the inverter and motor, when the cable length between them is long (10 m or more), to prevent thermal relay malfunction due to the harmonic waves that are generated by the switching operation on the inverter. Note that the thermal relay can be replaced with a current sensor to avoid the malfunction.
h) LCR filter	This filter converts the inverter output into a sinusoidal waveform.

(4)Wiring and Accessories

The table below lists the specifications of cables, crimp terminals, and terminal screw tightening torques for reference.

Input Voltage	Motor Output (kW)	Applicable inverter model NES1-	Wiring			Accessories Note1)		
			Gauge of power line cable (mm ²) Note3) Note4)	Size of terminal screw Terminal width (mm)	Tightening Torque (N-m)	Earth-leakage breaker (ELB) Note2) Note5)	Magnetic contactor (MC) Note2)	Fuse (UL-rated, class J,600V) Note6)
1-phase 200V	0.2	002SB*	AWG14 (2.0)	M3.5 (7.6)	1.0	EB-30E(5A)	HS10	10A
	0.4	004SB*	AWG14 (2.0)	M3.5 (7.6)	1.0	EB-30E(10A)	HS10	10A
	0.75	007SB*	AWG14 (2.0)	M4 (10)	1.4	EB-30E(15A)	HS10	15A
	1.5	015SB*	AWG10 (5.5)	M4 (10)	1.4	EB-30E(20A)	HS20	20A
	2.2	022SB*	AWG10 (5.5)	M4 (10)	1.4	EB-30E(20A)	HS20	30A
3-phase 200V	0.2	002LB*	AWG16 (1.25)	M3.5 (7.6)	1.0	EB-30E(5A)	HS10	10A
	0.4	004LB*	AWG16 (1.25)	M3.5 (7.6)	1.0	EB-30E(10A)	HS10	10A
	0.75	007LB*	AWG16 (1.25)	M3.5 (7.6)	1.0	EB-30E(10A)	HS10	15A
	1.5	015LB*	AWG14 (2.0)	M4 (10)	1.4	EB-30E(15A)	HS10	15A
	2.2	022LB*	AWG14 (2.0)	M4 (10)	1.4	EB-30E (20A)	HS20	20A
3-phase 400V	0.4	004HB*	AWG16 (1.25)	M4 (10)	1.4	EX-50C (5A)	HS10	10A
	0.75	007HB*	AWG16 (1.25)	M4 (10)	1.4	EX-50C(10A)	HS10	10A
	1.5	015HB*	AWG16 (1.25)	M4 (10)	1.4	EX-50C(10A)	HS10	10A
	2.2	022HB*	AWG14 (2.0)	M4 (10)	1.4	EX-50C(15A)	HS10	15A
	4.0	040HB*	AWG14 (2.0)	M4 (10)	1.4	EX-50C(15A)	HS10	15A

Note 1) The peripheral equipment described here is applicable when the inverter connects a standard Hitachi 3-phase, 4-pole squirrel-cage motor.

Note 2) Select breakers that have proper capacity. (Use breakers that comply with inverters.) Select above proper ELB capacity following above table for the 1pc inverter. 1pc inverter must be supplied by the above proper 1pc ELB.

Note 3) If the power line exceeds 20m, cable that is thicker than the specified applicable cable must be used for the power line.

Note 4) Use copper electric wire (HIV cable) of which the maximum allowable temperature of the insulation is 75°C.

Note 5) Use earth-leakage breakers (ELB) to ensure safety.

Note 6) To comply UL, use either ELB/or FUSE which is specified by UL for the Power supply for the inverter.

(Please refer to Chapter1 "1.3 Precautions Concerning Compliance with UL and cUL Standards")

Note 7) The earthed line, please use things more than electric wire diameter to show to the power line.

Note8) "*" changes by Restricted Distribution.

5.6 Wiring of the control circuit

(1) Wiring instructions

- 1) Terminals L and CM2 are common to I/O signals and isolated from each other.
Do not connect these common terminals to each other or ground them.
Do not ground these terminals via any external devices. (Check that the external devices connected to these terminals are not grounded.)
- 2) Use a shielded, twisted-pair cable (recommended gauge: 0.14-0.75 mm²) for connection to control circuit terminals, and connect the cable insulation to the corresponding common terminal.
- 3) The length of cables connected to control circuit terminals must be 20m or less.
- 4) Separate the control circuit wiring from the main circuit wiring (power line) and relay control circuit wiring. If these wirings intersect with each other unavoidably, square them with each other. Otherwise, the inverter may malfunction.
- 5) When connecting a contact to a control circuit terminal (e.g., an intelligent input terminal), use a relay contact (e.g., crossbar twin contact) in which even a very low current or voltage will not trigger any contact fault.
- 6) When connecting a relay to an intelligent output terminal, also connect a surge-absorbing diode in parallel with the relay.
- 7) Do not connect analog power supply terminals H and L or interface power supply terminals P24 and L to each other. Otherwise, the inverter may fail.
- 8) Control circuit terminal block has two columns up and down. Lower terminal may wire difficult to upper terminal wire to the first. Therefore, please first wiring to lower terminal.
- 9) After wiring, gently pull the wire, please make lead wire have securely connected.
- 10) Make sure the wires are not shorted each other.

(2) Layout of control circuit terminals

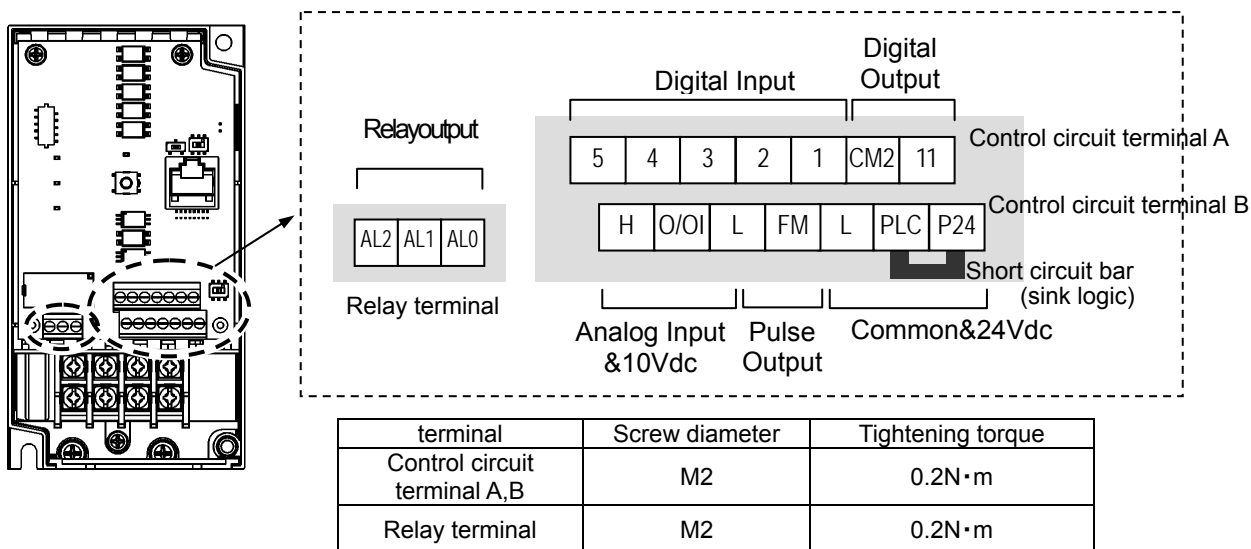

[example] (sink logic)

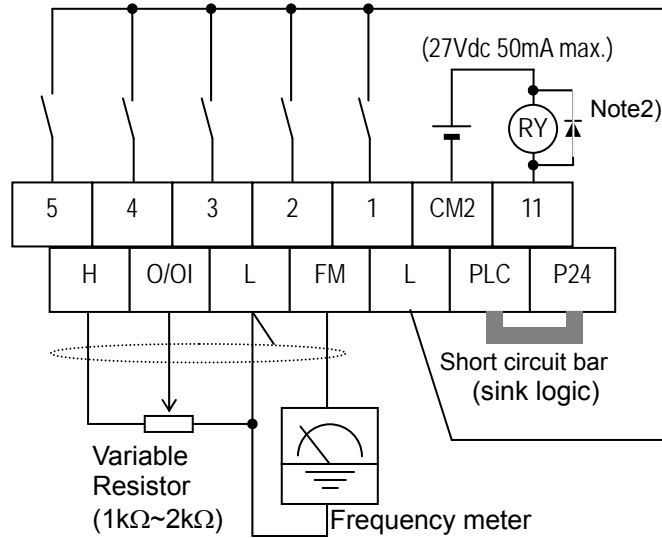

Note1) The above is a method to perform analog input(O/OI) by voltage input. It is necessary for SW6 on the board to be set for voltage input(default).

Note2) If you want to connect a relay to an intelligent output terminal, please connect a surge absorbing diode in parallel with the relay. The output circuit may malfunction by voltage surge.

(3) Switching the input control logic

- In the factory setting, and intelligent input terminals is the sink logic.

To switch the input control logic to the source logic, remove the jumper connecting terminals P24 and PLC on the control circuit block, and then connect terminals PLC and L with the jumper.

1) Sink logic

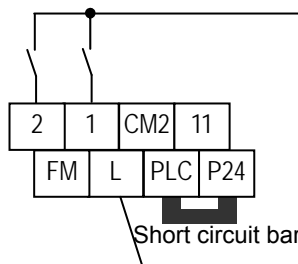

2) Source logic

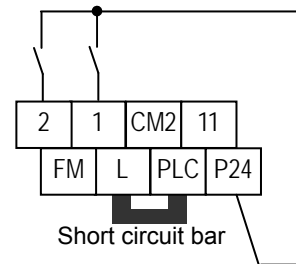

5.7 Connection with the programmable controller (PLC)

(1) Connecting a programmable controller to intelligent input terminals

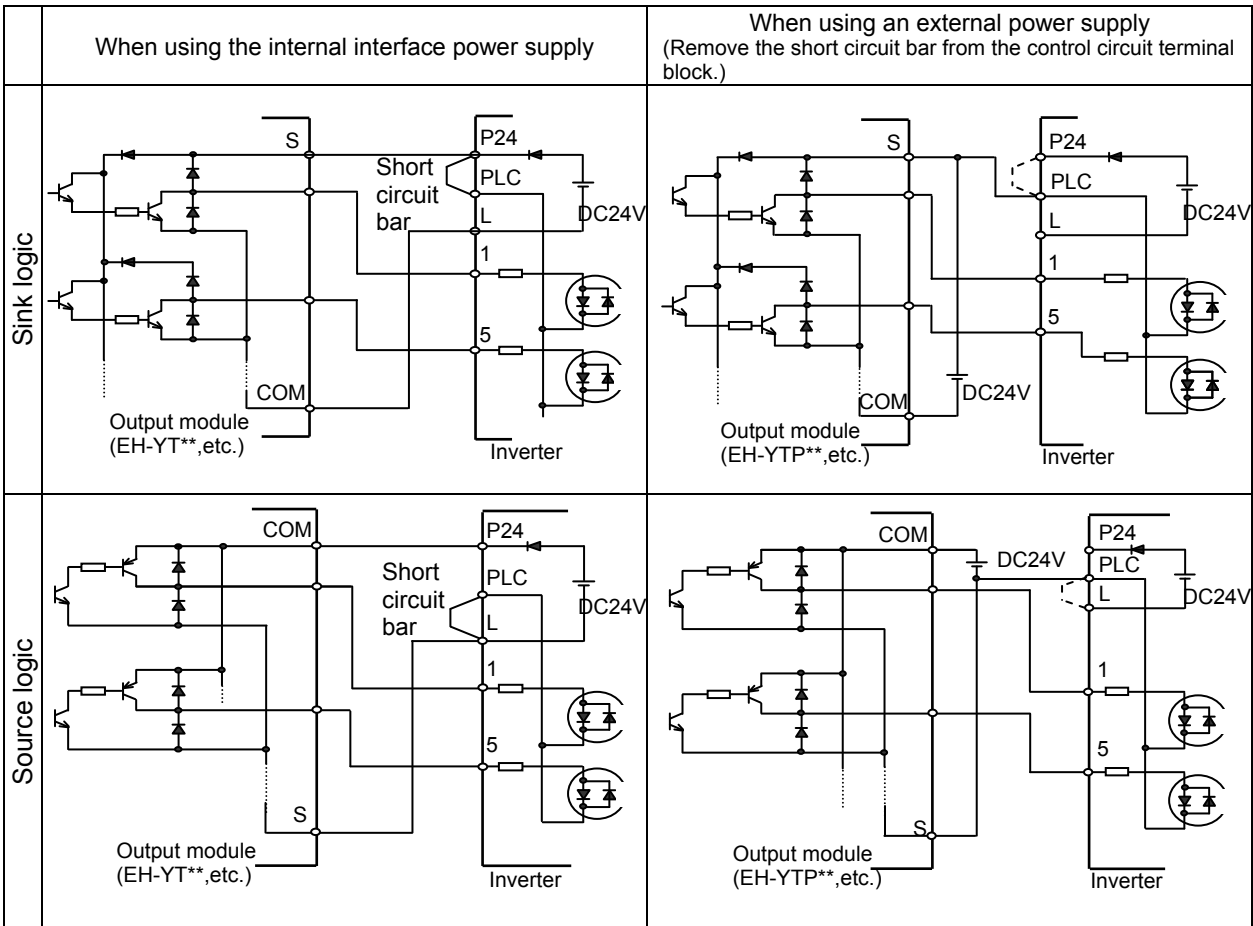

(2) Connecting a programmable controller to intelligent output terminals

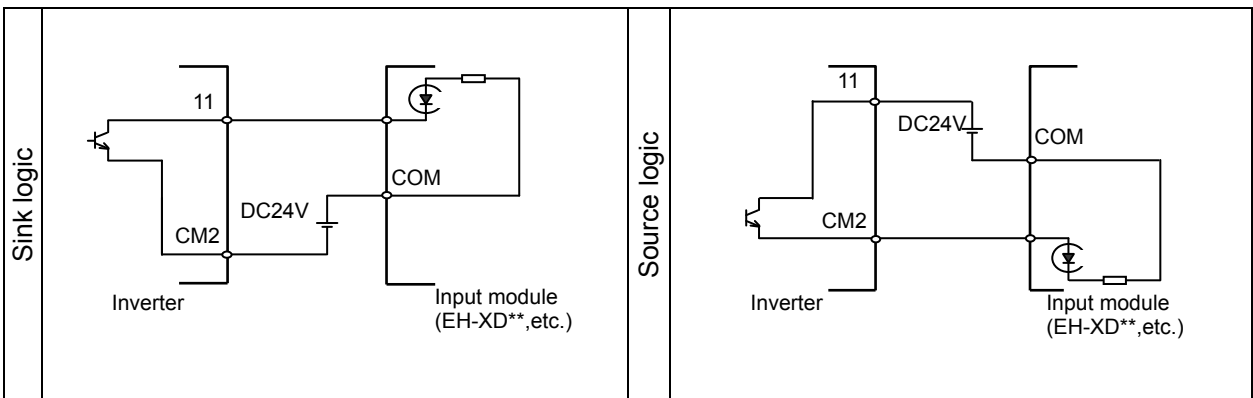

5.8 Notes on using multiple inverters

A plurality of inverter uses the common input and when inverter is timing of different power-on, as shown in the figure below the current flowing around. The input may be recognized as ON in spite of OFF. In this case, please put a diode(rated 50V/0.1A) as shown in the figure to prevent.

(1) Sink logic

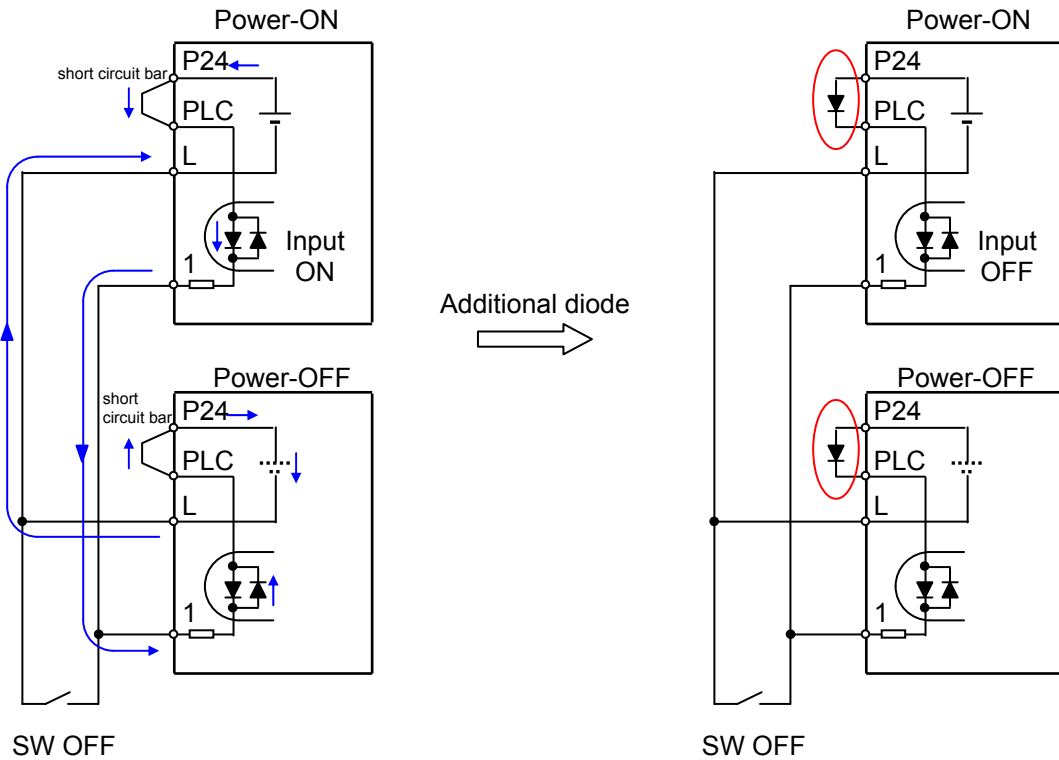

The input is recognized as ON in spite of OFF without Diode.

Providing a diode instead of the short circuit bar, so that the current flowing is prevented.

Chapter 5 Wiring

(2) Source logic

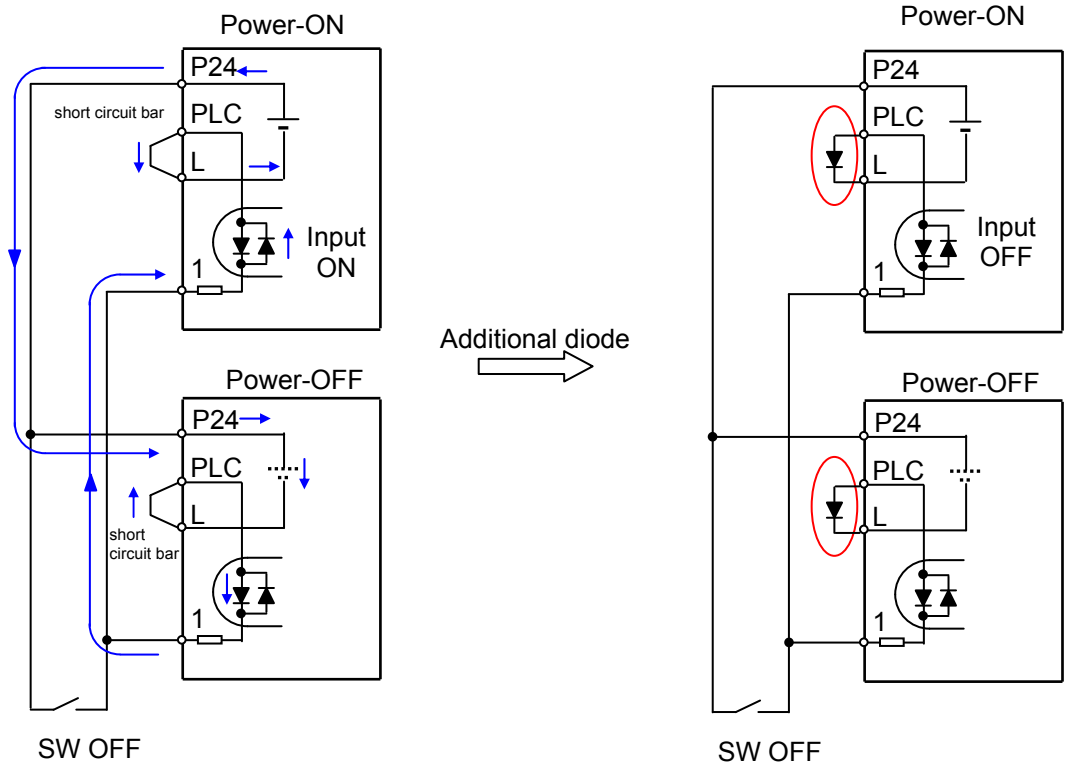

The input is recognized as ON in spite of OFF without Diode.

Providing a diode instead of the short circuit bar, so that the current flowing is prevented.

Chapter 6 Operation

This chapter describes typical methods of operating the inverter, how to operate the digital operator.

6.1	Precautions of Operation	6 - 1
6.2	Confirmation before power up the inverter	6 - 2
6.3	Changing parameters.....	6 - 2
6.4	Power up the inverter.....	6 - 3
6.5	How To Operate the Digital Operator.....	6 - 4
6.6	Motor Operation.....	6 - 11
6.7	Conduct a test run of the motor	6 - 17
6.8	When tripping occurs	6 - 19

6.1 Precautions of Operation

WARNING

- Please do not rotate suddenly. Check the direction of rotation at low frequencies. Otherwise, there is a danger of injury.
- While power is supplied to the inverter, do not touch any terminal or internal part of the inverter, check signals, or connect or disconnect any wire or connector. Otherwise, you run the risk of electric shock or fire.
- Be sure to close the top cover before turning on the inverter power. Do not open the top while power is being supplied to the inverter or voltage remains inside. Otherwise, you run the risk of electric shock.
- Do not operate switches with wet hands. Otherwise, you run the risk of electric shock.
- While power is supplied to the inverter, do not touch the terminal of the inverter, even if it has stopped. Otherwise, you run the risk of injury or fire.
- If the retry mode has been selected, the inverter will restart suddenly after a break in the tripping status. Stay away from the machine controlled by the inverter when the inverter is under such circumstances. (Design the machine so that human safety can be ensured, even when the inverter restarts suddenly.) Otherwise, you run the risk of injury.
- Do not select the retry mode for controlling an elevating or traveling device because output free-running status occurs in retry mode. Otherwise, you run the risk of injury or damage to the machine controlled by the inverter.
- If an operation command has been input to the inverter before a short-term power failure, the inverter may restart operation after the power recovery. If such a restart may put persons in danger, design a control circuit that disables the inverter from restarting after power recovery. Otherwise, you run the risk of injury.
- Prepare the additional emergency stop switch in addition to the stop key of the integrated operator and/or the optional operator. Otherwise, there is a danger of injury.
- If an operation command has been input to the inverter before the inverter enters alarm status, the inverter will restart suddenly when the alarm status is reset. Before resetting the alarm status, make sure that no operation command has been input. Otherwise, there is a danger of injury.
- While power is supplied to the inverter, do not touch any internal part of the inverter or insert a bar in it. Otherwise, you run the risk of electric shock or fire.
- Run/Stop/Reset is integrated in one button, before you press the button, please make sure that the machine(facility) Otherwise, you run the risk of injury or damage to the machine controlled by the inverter.

CAUTION

- Do not touch the heat sink, which heats up during the inverter operation. Otherwise, you run the risk of burn injury.
- The inverter allows you to easily control the speed of motor or machine operations. Before operating the inverter, confirm the capacity and ratings of the motor or machine controlled by the inverter. Otherwise, you run the risk of injury or damage to the machine controlled by the inverter.
- Install an external brake system if needed. Otherwise, you run the risk of injury.
- When using the inverter to operate a standard motor at a frequency of over 60 Hz, check the allowable motor speeds with the manufacturers of the motor and the machine to be driven and obtain their consent before starting inverter operation. Otherwise, you run the risk of injury or damage to the motor and machine.
- During inverter operation, check the motor for the direction of rotation, abnormal sound, and vibrations. Otherwise, you run the risk of injury or damage to the machine driven by the motor.
- Regardless Run command setting(A002/A202) if the key is pressed, inverter starts running. Therefore, if you selected Run command such as operator or terminal, please handle the key after you made sure that the machine/facility is operated safety.

6.2 Confirmation before power up the inverter

Please confirm the followings before operation.

- (1) Connection of the power input (R(L1)/L1,S(L2),T(L3)/N) and motor (U(T1), V(T2), W(T3)) is correctly connected. Otherwise there is a risk of inverter failure.
- (2) There must be no mis-connection of the control wiring. Otherwise there is a risk of inverter failure.
- (3) Earth grounding is properly connected. Otherwise there is a risk of electric shock.
- (4) There is no ground fault other than earth grounding terminal. Otherwise there is a risk of inverter malfunction.
- (5) There must be no short circuit by the wire chip etc., There must be no tools left inside the inverter. Otherwise there is a risk of inverter failure.
- (6) There must be no short circuit or ground fault at the output side. Otherwise there is a risk of inverter failure.
- (7) Front cover must be closed. When using the RS422/RS485 port, please use to open the window of the front cover. Otherwise there is a risk of electric shock.

6.3 Changing parameters

One of the following is required when changing parameters on NE-S1 series inverters.

- (1) Dedicated operator (NES1-OP)
The operator (NES1-OP) is used with integration onto the inverter. It is not possible to use the operator external with cable.
- (2) Digital operator (OPE-SRmini,OPE-S/SR/SBK)
Digital operator can be used with connector cable (ICS-1,3) and connected to the RS422/RS485 port (RJ45) in the inverter. Turn the changeover switch to the operator side (OFF side) in that case. Refer to the manual for each operator for the detailed information.
- (3) 5-line LCD operator (WOP)
WOP having serial number of "16918938000081" or later (2011/07 production) is applied to NE-S1 series inverter. (English only)
WOP can be used with connector cable (ICS-1,3) and connected to the RS422/RS485 port (RJ45) in the inverter. Turn the changeover switch to the operator side (OFF side) in that case. Refer to the manual for WOP for the detailed information.
- (4) PC programming tool (ProDriveNext)
ProDriveNext Version "1.2.33.010" and later is applied to the NE-S1 series inverter.
PC can be used with connector cable and connected to the RS422/RS485 port (RJ45) in the inverter. Turn the changeover switch to the operator side (OFF side) in that case. Refer to the manual for ProDriveNext for the detailed information.
It is necessary to turn power off to store the changed data.

6.4 Power up the inverter

- (1) Power up the inverter after confirming the items shown in above section 6.2.
- (2) Confirm the LED is emitting like shown below.
 - Standard panel : Confirm that both PWR lamp and Key valid lamp are emitting
 - Dedicated operator (NES1-OP) : Confirm that the 7-SEG LED is emitting. Display will be the one set by b038 (Initial display selection). "0.00(output frequency monitor)" will be displayed under default condition.
- (3) Refer to section "6.5" and set required parameters. And then refer to section "6.6 Motor operation".

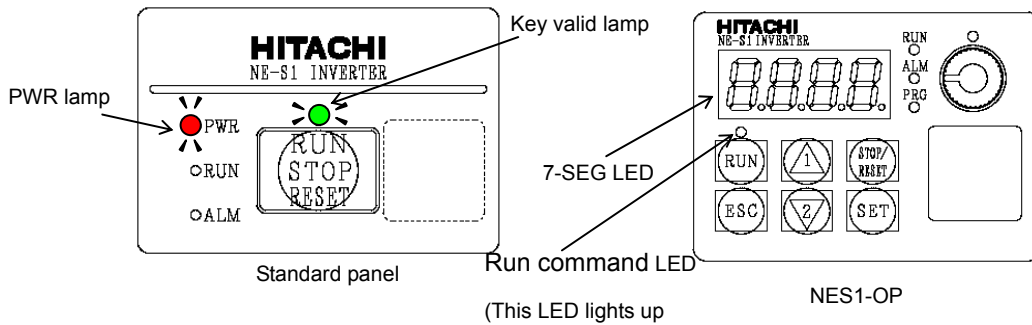

(This LED lights up when the key operation is enabled.)

Note 1) It will take around 1.5 seconds for the inverter to be ready(each LED emits). Please take into account this delay in case of an application , which this delay will be important.

Chapter 6 Operation

6.5 How To Operate the Inverter

(A) Names and functions of components

Standard panel

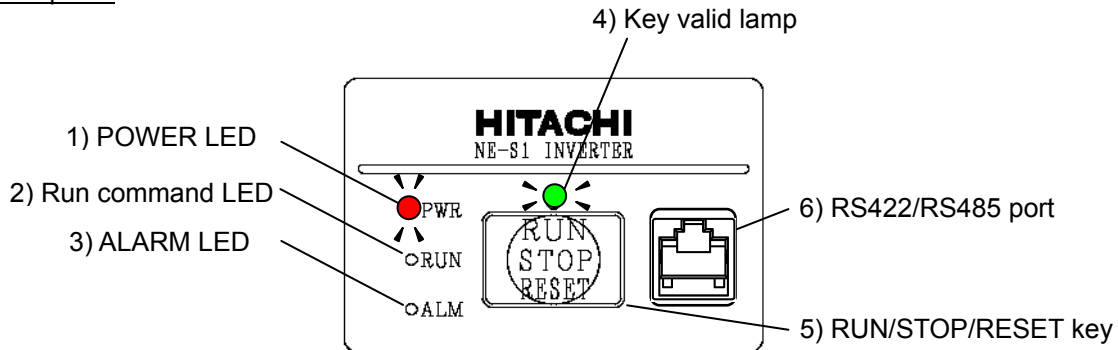

Name	Description
1) POWER LED	- Turns on (red) during inverter is powered up
2) Run command LED	- Turns on (green) during inverter operation. (This turns ON either Run command is given, or the inverter is giving out power. Therefore it keeps turning on during 0 Hz driving, or keeps turning on during deceleration period even after the run command is OFF.
3) ALARM LED	- Turns on (red) when the inverter is in trip status. - See section 6.8 for details on clearing alarms.
4) Key valid lamp	- Turns on (green) when the RUN/STOP/RESET is ready. It turns off when there is a RUN command. If the run command is being given from the RUN/STOP/RESET key, the lamp is being on during deceleration period even after the run command is OFF. While Run command is given such as FW(RV) terminal,if "RUN/STOP/RESET key" was pressed, even Run command is OFF, the "Key valid lamp" is OFF until inverter is Stopped.
5)RUN/STOP/RESET key	- Makes inverter run, stop and reset. RUN/STOP/RESET key is set default and it can be made invalid by the key sensitivity selection (C151) to "no". - It restores from the trip state if the inverter is in trip state. - If the ModBus communication is selected, it can be temporary changed to a external operator mode if the inverter is powered up with pressing the RUN/STOP/RESET key and keep it pressing 5seconds,and take off from the key.. Changeover switch must be changed later on. Note 1)
6) RS422/RS485 port (RJ45)	- This is a port for external operator, Modbus connection, or ProDriveNext (RS485/operator changeover switch must be operated) before Power ON. In case of Modbus communication, it is necessary to set the changeover switch and parameter (C070). Display of NES1-OP will be according to the parameter set of b150 continuously, if the external operator is connected while the dedicated operator (NES1-OP) is integrated. Note2)

Note 1) It is necessary to set changeover switch and the parameter C070 for releasing the Modbus communication. If the parameter C070 is set to Modbus, external operator via the RJ45 jack cannot be used.

Note 2) Connecting work on RJ45 jack must be done during the inverter power off.

(B) Dedicated operator (NES1-OP) *same applies to external Operator

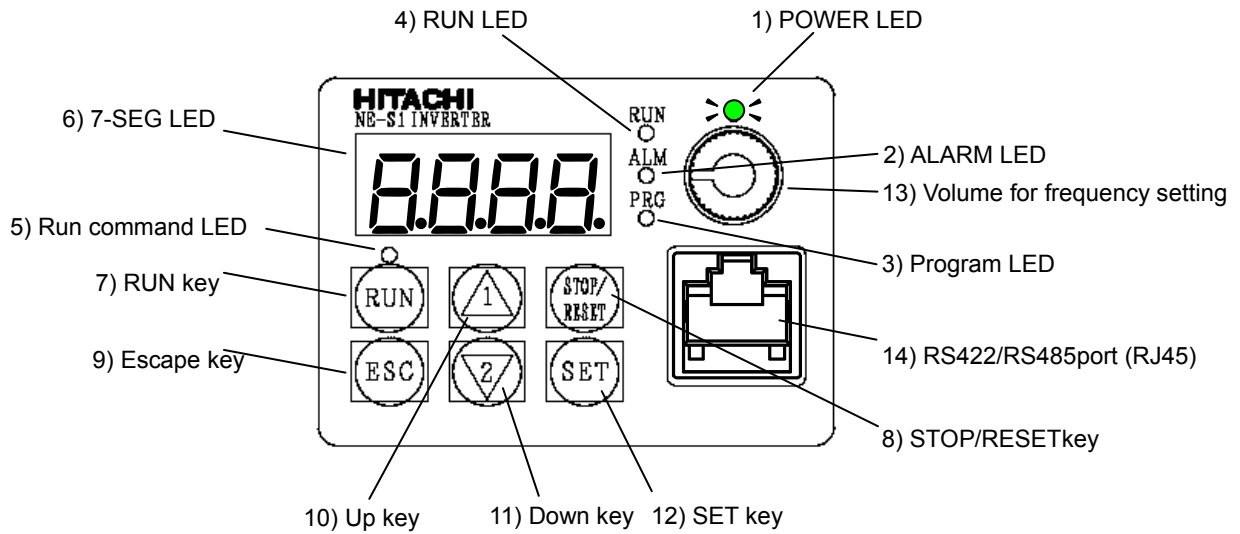

Name	Description
1) POWER LED	- Turns ON (Green) while the inverter is powered up.
2) ALARM LED	- Turns ON (Red) when the inverter trips. - See Chapter 6.8 for details on clearing alarms.
3)Program LED	- Turns ON (Green) when the display shows changeable parameter. - Blinks when there is a mismatch in setting. Refer to "9.3".
4) RUN LED	- Turns ON (Green) when the inverter is driving the motor. (RUN LED is lit even when the set frequency is put in operation command 0Hz or during deceleration after the operation command OFF.)
5) RUN command LED	-Turns ON (Green) when a Run command is set to the operator. (Run key is effective.)
6) 7-SEG LED	- Shows each parameter, monitors etc.
7) RUN key	- Makes inverter run. But operation command destination must be the operator. - Set the operation direction in F004.
8) STOP/RESETkey	- Makes inverter decelerates to a stop. (Even if operation command is non-operator, Stop key is valid. Stop key can be disabled in the settings[b087].) - Reset the inverter when it is in trip situation
9) Escape key	- Go to the top of next function group, when a function mode is shown - Cancel the setting and return to the function code, when a data is shown - Moves the cursor to a digit left, when it is in digit-to-digit setting mode - Pressing for 1 second leads to display data of d00 I , regardless of current display.
10) Up key 11) Down key	- Increase or decrease the data. It accelerates hold down a key. - Pressing the both keys at the same time gives you the digit-to-digit edit.
12) SET key	- Go to the data display mode when a function code is shown - Sets the data and go back to show the function code, when data is shown. - Moves the cursor to a digit right, when it is in digit-to-digit display mode
13) Volume for frequency setting	- This is a Volume for frequency setting. (A001=00(VR))

Chapter 6 Operation

14) RS422/RS485port (RJ45)	- This is a port for external operator, Modbus connection, or ProDriveNext (RS485/operator changeover switch must be operated) before Power ON. In case of Modbus communication, it is necessary to set the changeover switch and parameter (C070). Display of NES1-OP will be according to the parameter set of b150 continuously, if the external operator is connected while the dedicated operator (NES1-OP) is integrated. Note1)
----------------------------	--

Note 1) Connecting work on RJ45 jack must be done during the inverter power off.

(C) Key operations : This section shows the key operations of the digital operator and Dedicated operator (NES1-OP).

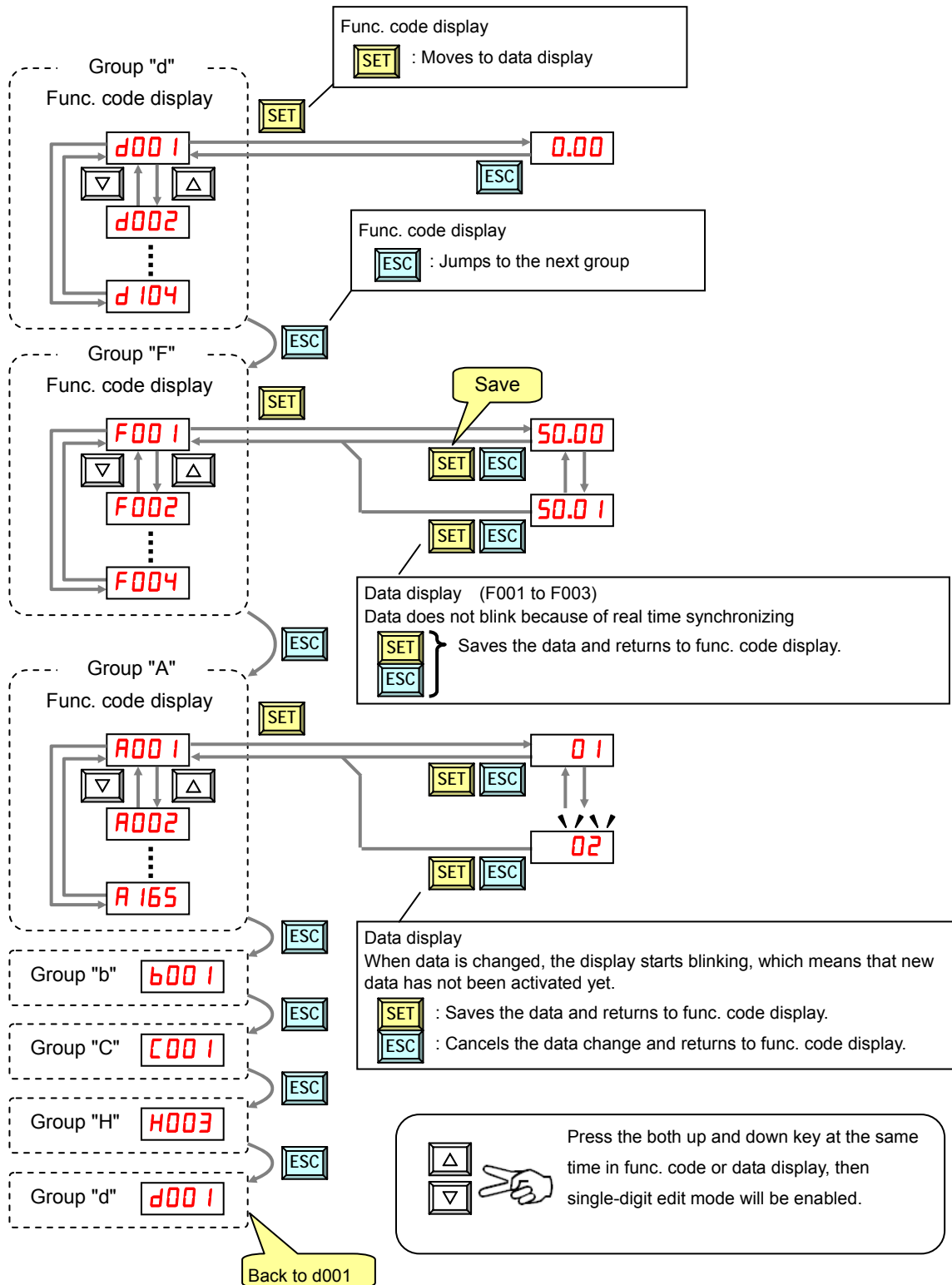

Note) Pressing the [ESC] key will make the display go to the top of next function group, regardless the display contents. (e.g. **A02 1** → [ESC] → **b00 1**)

Chapter 6 Operation

[Single-Digit Edit Mode]

If a target function code or data is far from current data, using the single-digit edit mode makes it quicker. Pressing the up key and down key at the same time leads you to go into the digit-to-digit changing mode.

While in Single-digit edit mode (single digit is blinking):

[SET] : Move cursor to right or set the func.code/data (lowest digit only)

[ESC] : Move cursor to left.

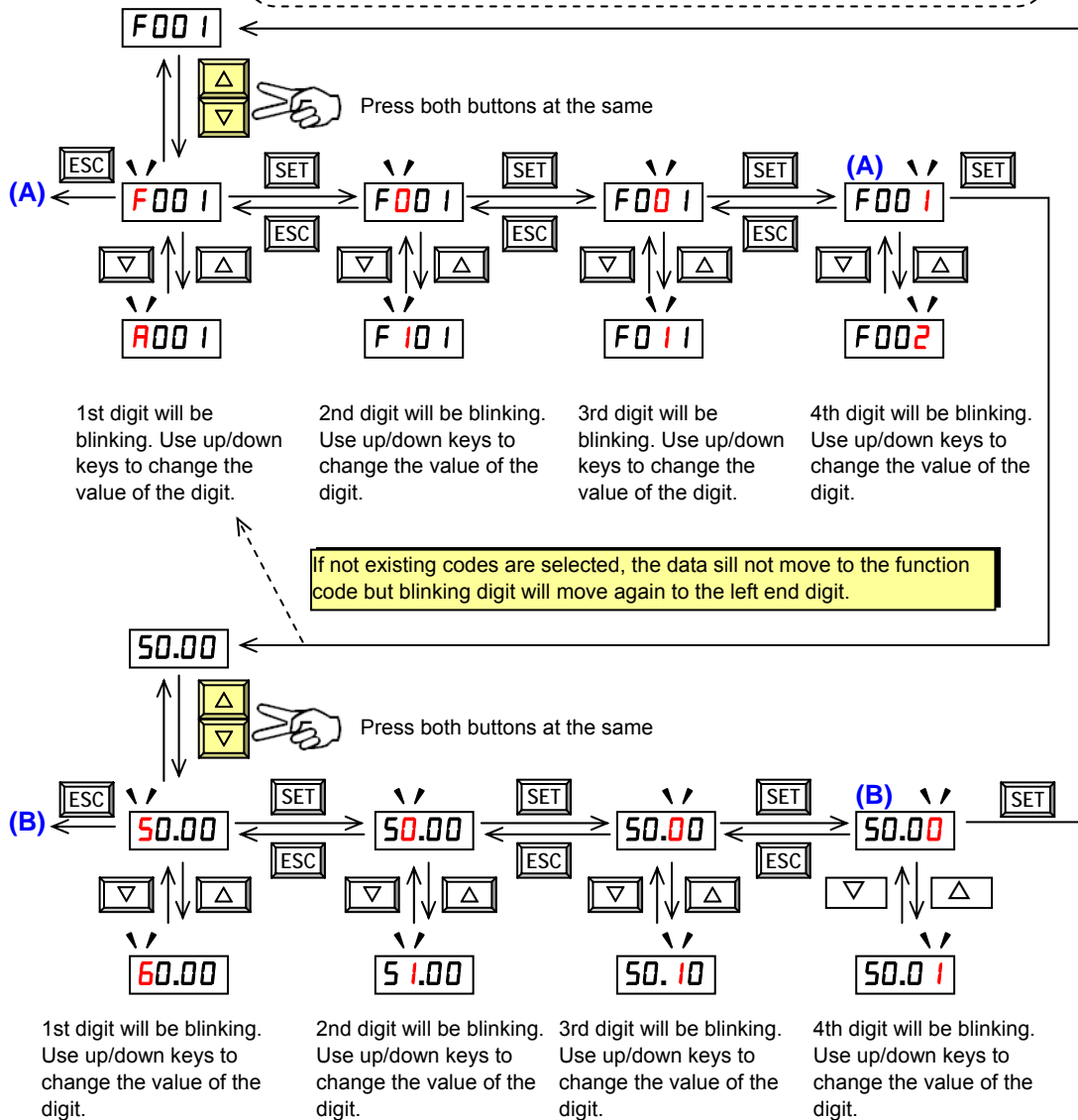

[Setting example]

After power ON, changing from 0.00 display to change the **b003** (carrier frequency) data.

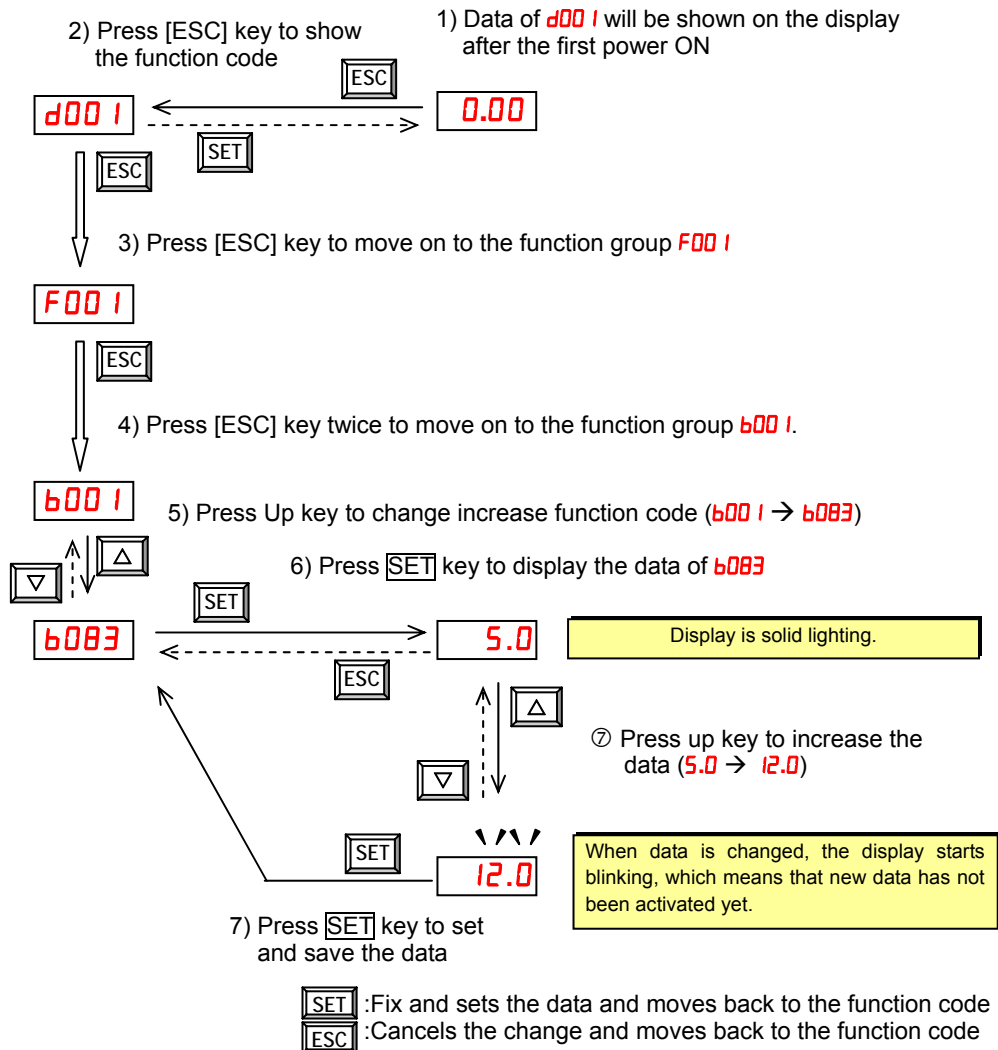

Note1) Function code **dxxx** are for monitor and not possible to change.

Function codes **Fxxx** other than **F004** are reflected on the performance just after changing the data (before pressing [SET] key), and there will be no blinking.

Note2) Keep pressing for more than 1 second leads to d001 display, regardless the display situation. But note that the display will circulates while keep pressing the [ESC] key because of the original function of the key.

(e.g. **F001** → **A001** → **b001** → **C001** → ... → displays **50.00** after 1 second)

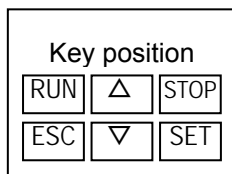

	When a function code is shown...	When a data is shown...
[ESC] key	Move on to the next function group	Cancels the change and moves back to the function code
[SET] key	Move on to the data display	Fix and sets the data and moves back to the function code
▲ key	Increase function code	Increase data value
▼ key	Decrease function code	Decrease data value

Chapter 6 Operation

[Connection of the operator for another model]

NES1 can operate even (OPE-S/SR/SBK, OPE-SR mini). STR key and FUNC key are different from the behavior of conventional key operation system. In order to transition from the func code display to the data display is the STR key, not the FUNC key. NES1 is a function group transfer by pressing the FUNC key, when operator shows the func code display. Operator displays the d001 when it hold down a FUNC key for over a second even any state.

NES1 and OPE-SR mini combination

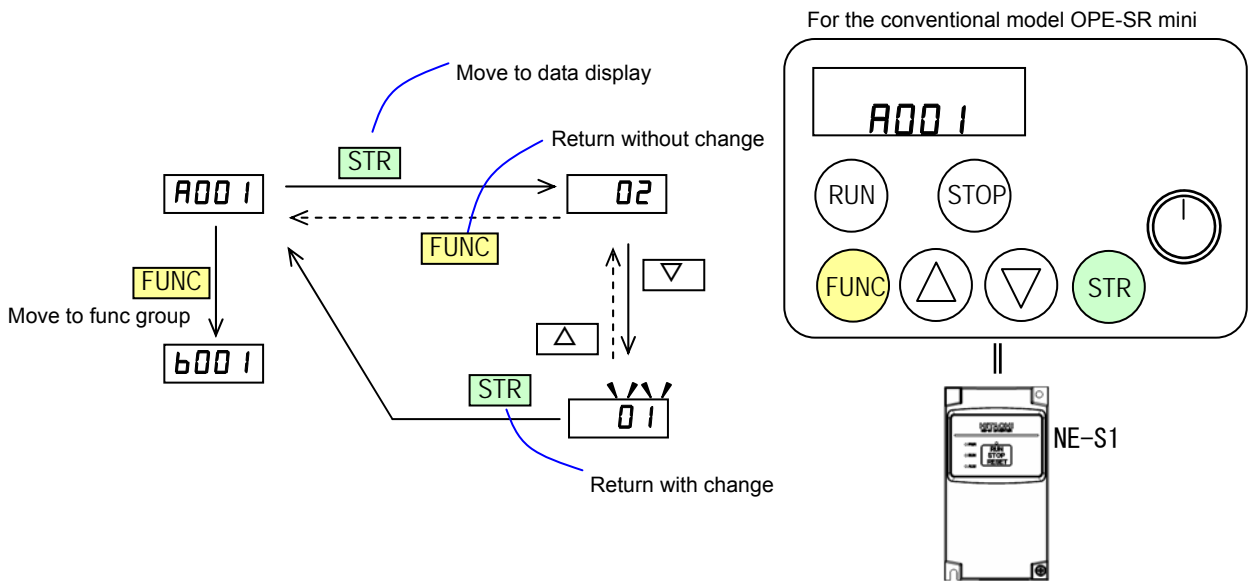

[Reference] Conventional inverter model and OPE-SR mini combination

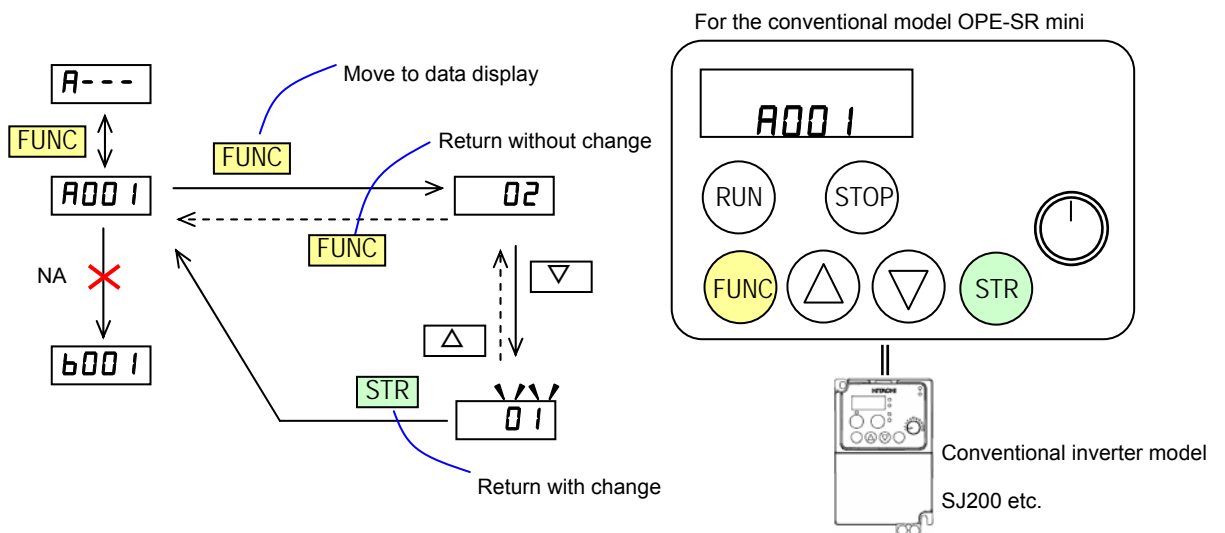

6.6 Motor Operation

Both “Run command” and “frequency command” is necessary to run the motor. Motor does not run if one of each is missing. For example, motor will not run when a run command is given, but a frequency command is 0Hz. Additionally, the motor will not run if a FRS (free run stop) signal (and the like) is being given.

NE-S1 series inverter has following way to set the run command and frequency command. (This is an example of sink logic and uses internal control power supply.)

(A) Driving with the standard panel

RUN/STOP/RESET key on the standard operation panel is effective regardless of the setting of the driving order method(A002). Thus, following driving method (1) to (3) is possible without an option if it is factory default setting.

(1) Method to perform driving in RUN/STOP/RESET key and perform frequency setting in Multispeed select

This is the operation method using Run command is given by "RUN/STOP/RESET key" & Frequency setting is given by Fixed value such as 20/40/60Hz, Accel&Decel time is 10 seconds. If you don't need to change such as Accel&Decel time, optional Operator is not required.) To set the Freq. setting, use the Multi-speed frequency setting (1=60Hz),(2=40Hz),(3=20Hz).

■ Setup

Function Name	Code	Data	Note
Input [3] function	C003	02(CF1)	Default
Input [4] function	C004	03(CF2)	

The initial value of Acceleration/ Deceleration time is 10sec.

Please change the following parameters as needed.

Function Name	Code	Setting Range	Note
Acceleration time	F002	0.00 to 3600sec.	Default : 10 sec.
Deceleration time	F003	0.00 to 3600sec.	Default : 10 sec.

* One of the following is required when changing parameters on NE-S1 series inverters.

- a) Dedicated operator (NES1-OP)
- b) Digital operator
- c) 5-line LCD operator
- d) Modbus
- e) PC programming tool (ProDriveNext)

■ Control circuit terminals wiring (Sink logic)

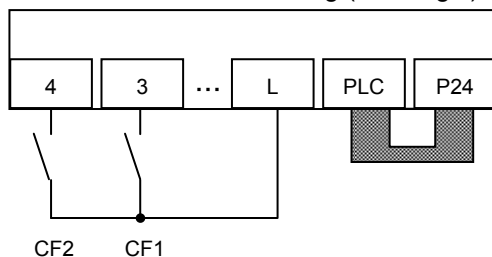

■ Example of use (default)

Restricted Distribution Other (Standard)	Restricted Distribution China / Europe	Code	Intelligent input terminal [3]	Intelligent input terminal [4]
60Hz order	50Hz order	A021(multi- speed freq. 1)	OFF	ON
40Hz order	35Hz order	A022(multi- speed freq. 2)	ON	OFF
20Hz order	20Hz order	A023(multi- speed freq. 3)	ON	ON

Chapter 6 Operation

(2) Method to perform driving in RUN/STOP/RESET key and perform frequency setting in volume resistor

This is the operation method using Run command is given by "RUN/STOP/RESET key" & Frequency setting is given by analog input such as O-L voltage, Accel&Decel time is 10 seconds. (If you don't need to change such as Accel&Decel time, optional Operator is not required.) Below diagram is to set the external Freq. setting connecting H-O-L volume to supply O-L voltage.

■ Setup

Function Name	Code	Data	Note
Frequency source	A001	01 (Control circuit terminals)	Default

The initial value of Acceleration/ Deceleration time is 10sec.
Please change the following parameters as needed.

Function Name	Code	Setting Range	Note
Acceleration time	F002	0.00 to 3600 sec.	default : 10 sec.
Deceleration time	F003	0.00 to 3600 sec.	default : 10 sec.

* One of the following is required when changing parameters on NE-S1 series inverters.

- a) Dedicated operator (NES1-OP)
- b) Digital operator
- c) 5-line LCD operator
- d) Modbus
- e) PC programming tool (ProDriveNext)

■ Control circuit terminals wiring (Sink logic)

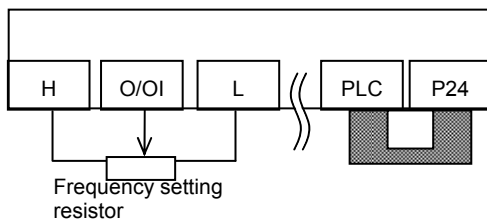

Note)

The above is a method to perform analog input(O/OI) by voltage input. It is necessary for SW6 on the board to be set for voltage input(default). →

(3) Method to perform driving in FW/RV terminal and perform frequency setting in volume resistor

This is the operation method using Run command is given by intelligent input terminal such as FW(RV) function & Frequency setting is given by analog input such as O-L voltage. (If you don't need to change such as Accel&Decel time, optional Operator is not required.) Below diagram is to set the external Freq. setting connecting H-O-L volume to supply O-L voltage.

■ Setup

Function Name	Code	Data	Note
Frequency source	A001	01 (Control circuit terminals)	Default
Run command source	A002	01 (Control circuit terminals)	Default
Input [1] function	C001	00 (FW)	Default
Input [2] function	C002	01 (RV)	

The initial value of Acceleration/ Deceleration time is 10sec.
Please change the following parameters as needed.

Function Name	Code	Setting Range	Note
Acceleration time	F002	0.00 to 3600 sec.	Default : 10 sec.
Deceleration time	F003	0.00 to 3600 sec.	Default : 10 sec.

* One of the following is required when changing parameters on NE-S1 series inverters.

- a) Dedicated operator (NES1-OP)
- b) Digital operator
- c) 5-line LCD operator
- d) Modbus
- e) PC programming tool (ProDriveNext)

■ Control circuit terminals wiring (Sink logic)

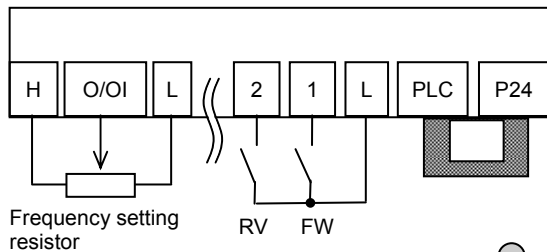

Note)
The above is a method to perform analog input(O/OI) by voltage input. It is necessary for SW6 on the board to be set for voltage input(default). →

Chapter 6 Operation

(B) Method to perform driving with the dedicated operator (NES1-OP)

*same applies to external Operator (OPE-S/SR/SBK,OPE-SR mini)

(1) Setting the operation command and Frequency command by operator (*Must be set by the operator.)
How to drive by key operation of the Dedicated operator.

■ Setup

Function Name	Code	Data	Note
Frequency source	A001	02(Operator)	
Run command source	A002	02(Operator)	Run command LED light up
Output frequency setting	F001	0.0 to A004(Max frequency) (default is 0.00Hz.)	
Keypad RUN key routing	F004	00(Forward) / 01(Reverse)	Can not be changed during operation

The initial value of the acceleration and deceleration time is 10 seconds. Please change the following parameters as necessary.

Function Name	Code	Setting Range	Note
Acceleration time (1)	F002	0.00 to 3600 seconds	Initial value : 10.00 seconds
Deceleration time (1)	F003	0.00 to 3600 seconds	Initial value : 10.00 seconds

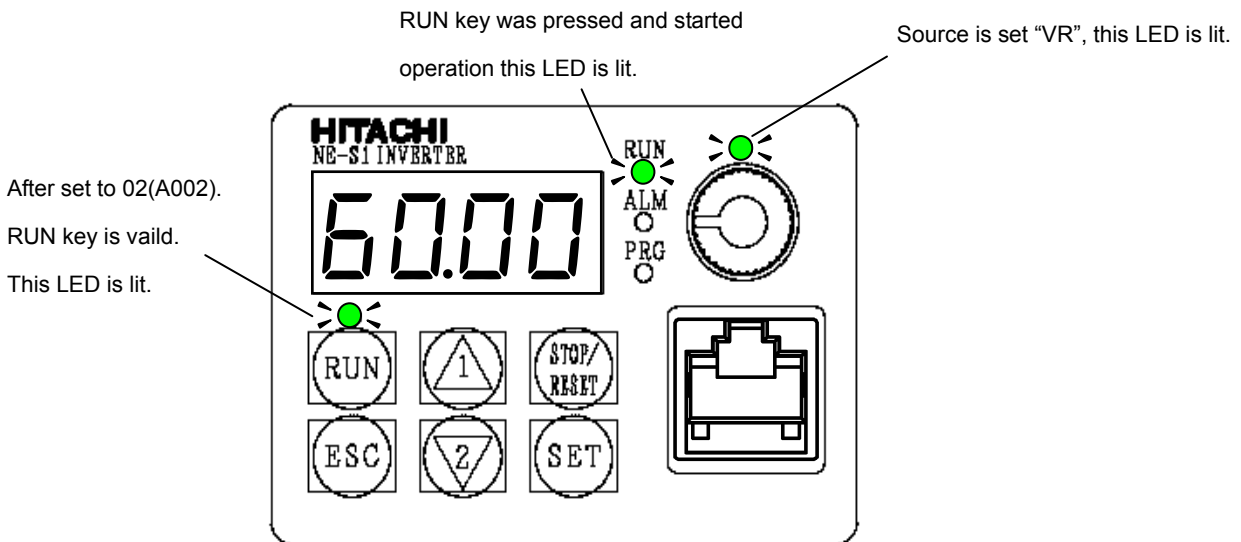

■ The control circuit terminal block wiring : No connect

■ Operation

Please be operated in accordance with section 6.7.

(2) Carried out in 3-wire input to operation / stop. Carried out in the frequency setting analog current signal(0 to 20mA).

(Setting must be changed by the operator.)

■ Setup

Function Name	Code	Data	Note
Frequency source	A001	01(The control circuit terminal)	Initial value
Run command source	A002	01(The control circuit terminal)	Initial value
Input [1] function	C001	20(Starting the motor) *1	
Input [2] function	C002	21(Stopping the motor) *1	
Input [3] function	C003	22(Switching the motor operation direction) *1	

*1 : Details 3-wire input mode refer to 7.5.3.

The initial value of the acceleration and deceleration time is 10 seconds. Please change the following parameters as necessary.

Function Name	Code	Setting Range	Note
Acceleration time (1)	F002	0.00 to 3600 seconds	Initial value : 10.00 seconds
Deceleration time (1)	F003	0.00 to 3600 seconds	Initial value : 10.00 seconds

SW6 must be set to the current. (Refer to 5.4)

When used with 4 to 20mA, you need to change the following parameters.

Function Name	Code	Data	Note
[O/OI] input active range start voltage	A013	20%	Initial value : 0%

* One of the following is required when changing parameters on NE-S1 series inverters.

- a) Dedicated operator (NES1-OP) b) Digital operator c) 5-line LCD operator
- d) Modbus e) PC programming tool (ProDriveNext)

■ The control circuit terminal block wiring (Sink logic)

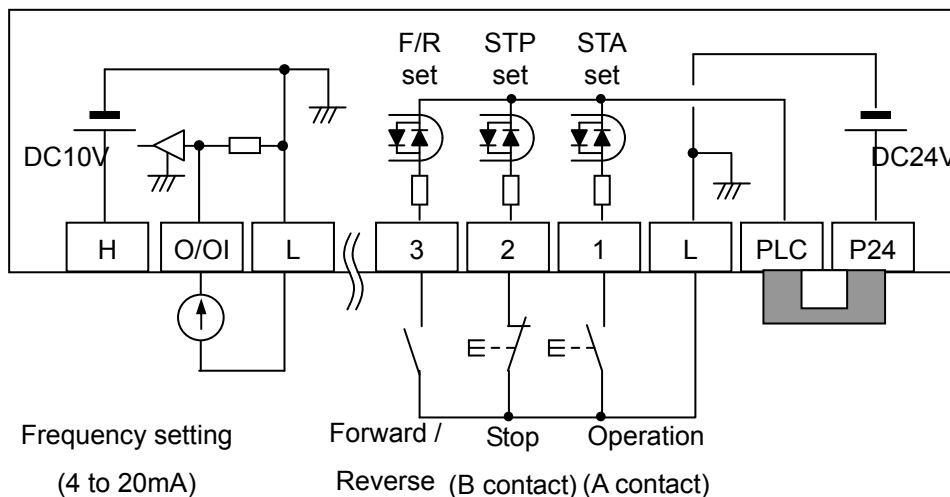

Chapter 6 Operation

* This wiring diagram is an example of using the built-in power inverter. Refer to Section 5.6, when you use an external power supply.

■ Operation

Please be operated in accordance with section 6.7.

6.7 Test Run with the motor

The following figure shows an example of basic connection is basic. Please refer to section 6.6 wiring for operation command and frequency command from the control circuit terminal block. On how to operate the parameter settings, please refer to section 6.5. To set the parameter, the operator is required.

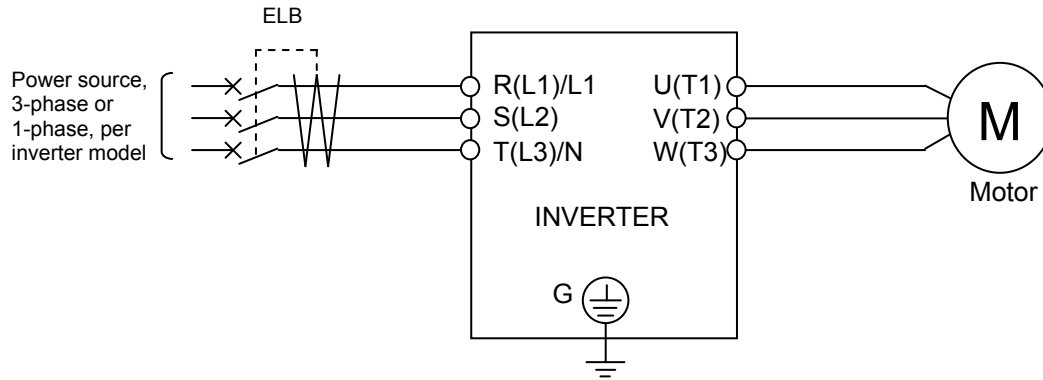

No.	Procedure
1	Please check whether there is any problem with the wiring.
2	Turn on the power to the inverter.(POWER lamp(red) lights.)
	In case of input operation command and frequency command without operator.(State initial shipment) *1)
3	Turns on both intelligent input terminal 3,4(CF1,CF2). (Multi-speed freq. 3 : The initial value is set 20Hz.)
4	Push RUN/STOP/RESET key. RUN lamp(while driving) is lit.
5	Please check and that there is no abnormality in the inverter and motor rotation direction motor rotation speed. If the direction of rotation of the motor is different, please turn off the inverter and cheak Power lamp is OFF.Please replace the two phases of the three-phase wiring of the output.
6	If there are no problems, only to turn on intelligent input terminal 3 (CF1). (Multi-speed freq. 3 : The initial value is set 60Hz.)
7	After checking the operation, push RUN/STOP/RESET key. Motor starts to slow down. The RUN lump(while driving) turns off when the motor is stopped.
	In case of input operation command and frequency command from control circuit terminal block.
3	Check that the the input value is (zero) to O / OI of the frequency command. The only one on the an intelligent input terminal 1(FW) or intelligent input terminal 2(RV). RUN lamp(while driving) is lit.
4	Gradually increasing the analog voltage / current frequency command to O/OI.
5	Please check and that there is no abnormality in the inverter and motor rotation direction motor rotation speed. If the direction of rotation of the motor is different, please turn off the inverter and cheak Power lamp is OFF.Please replace the two phases of the three-phase wiring of the output.
6	If there are no problems, gradually increasing the analog voltage / current to O/OI.
7	After checking the operation, the only one off the an intelligent input terminal 1(FW) or intelligent input terminal 2(RV). The RUN lump(while driving) turns off when the motor is stopped.
	In case of input operation command and frequency command from operator. *1)
3	Set to "operator" frequency source setting. (A001=02)

Chapter 6 Operation

4	Set to "operator" run command source setting. (A002=02)
5	Set the output frequency. (F001) It is recommended to first slow and for the safety of about 10Hz.
6	Set the operation direction. (F004)
7	Set "Frequency output" to the monitor display on the operator. Displays the (d001). Then press the SET key. Checking the "0.00"(Hz).
8	Press the RUN key. Motor starts to rotate. Then, the operator's RUN(while driving) lamp is lit.
9	Please check and that there is no abnormality in the inverter and motor rotation direction motor rotation speed. The direction of rotation of the motor, refer to [d003] display.
10	If there are no problems, gradually increase the output frequency in F001.
11	After checking the operation, push STOP key. Motor starts to slow down. The RUN lump(while driving) turns off when the motor is stopped.

*1)"Operator" refers to Dedicated operator(NES1-OP), external digital operator(OPE-S/SR/SBK, OPE-SR mini), 5 line LCD operator(WOP).

■point to be checked

- Whether there is any trip in the middle of acceleration and deceleration. Frequency meter and check whether the correct number of revolutions.
- When an overcurrent trip or overvoltage trip occurs during the test run, please make sure the input and the output of the inverter state, the load condition.
- When an overcurrent trip or overvoltage trip occurs during the test run, please increase the length of the acceleration (F002)and deceleration time (F003). The operator is required to change the acceleration and deceleration time.
- Check the Output Current Monitor (d002), DC voltage monitor(d102). Ensure that there is a margin to the value of the current and voltage trip value. To check the monitor, operator is required.

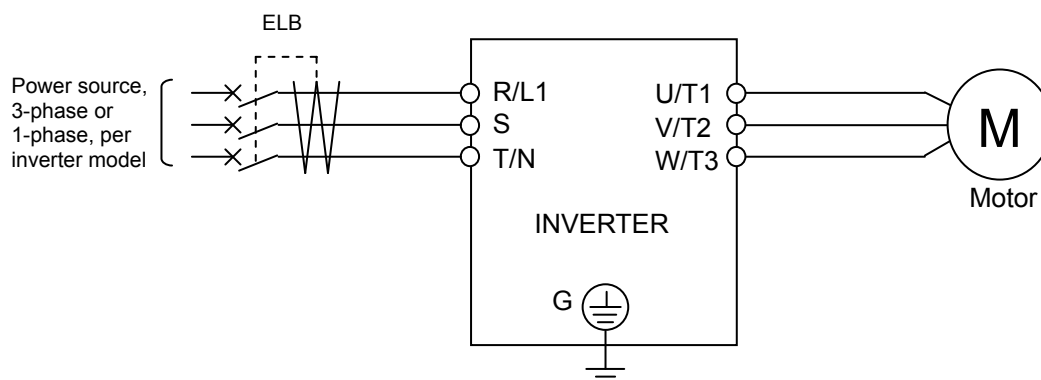

6.8 When tripping occurs

During operation, If any abnormalities (overcurrent, overload, etc.) is detected, and in order to protect the motor and inverter, the inverter output is shut off to the motor. ALARM lamp is lit at the same time. Then, it displays an error code. This chain of operations is called the trip. Motor is in free-run mode due to trip. To investigate the cause of the error from the error code that is displayed. And remove the cause of the error. During the trip, a run command isn't accepted. Press the [RUN/STOP/RESET]key to cancel the trip. If reset is assigned to an intelligent input terminal, please reset input "ON to OFF". However, depending on the cause of trip may not be able to cancel the trip by reset. In this case, the power is turned off and turned on again. Before reset execution please review the various input signals such as operation command. Please note that If operation command signal remains ON, restart immediately after the reset operation

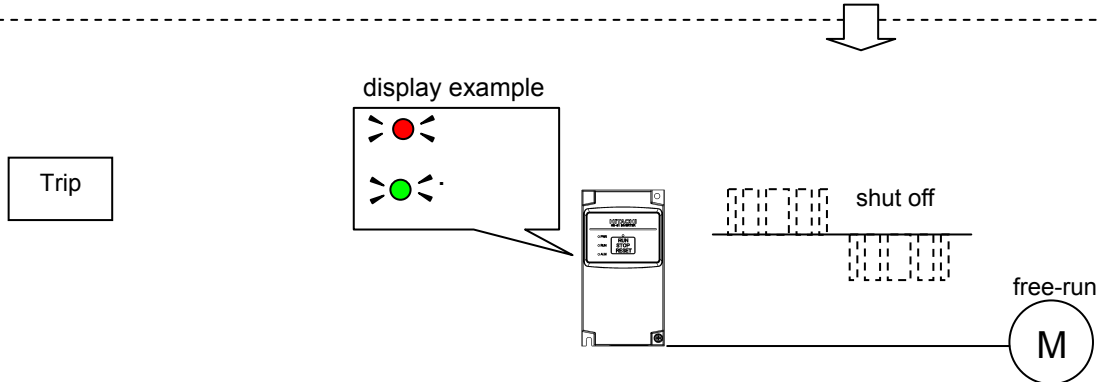
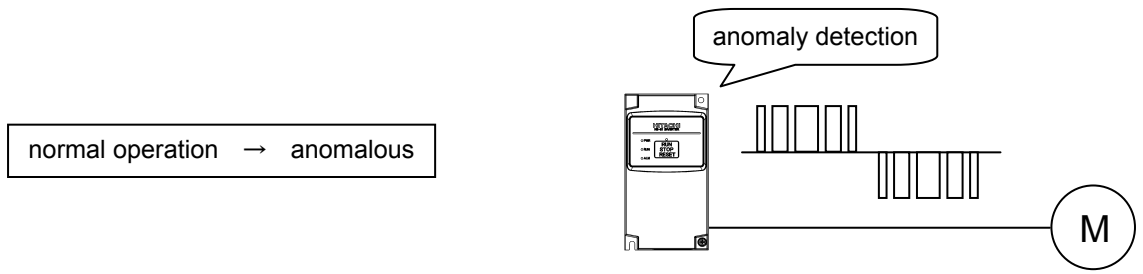

Refer to Chapter 9 for more information on error

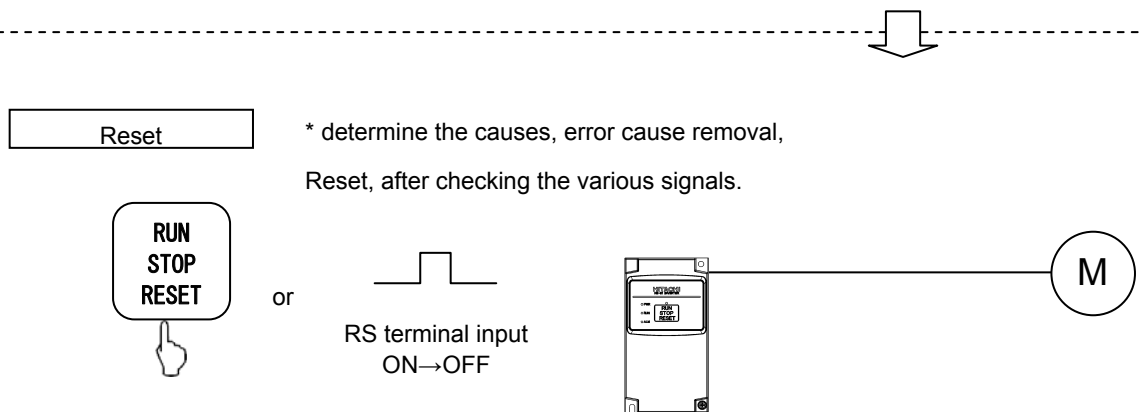

Chapter 6 Operation

Overview of the operation at the time of trip

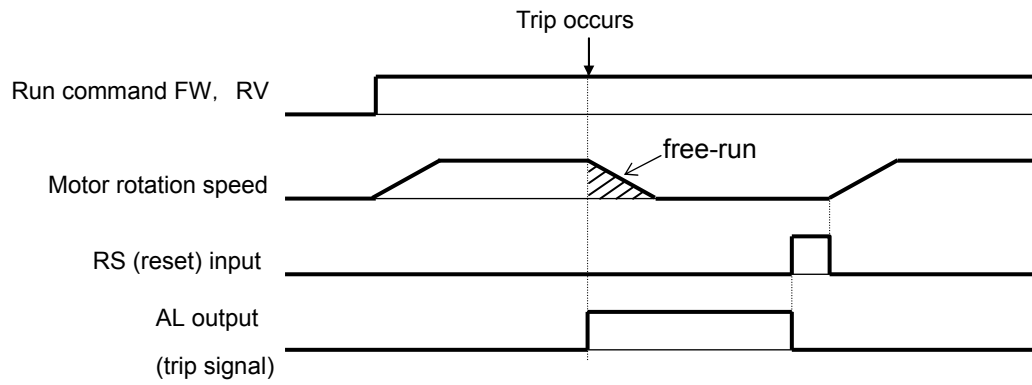

Chapter 7 Explanation of Functions

This chapter describes the functions of the inverter.

To change a parameter setting or monitoring the parameters, you must have operator(NES1-OP,OPE-SRmini,OPE-S/SR/SBK,WOP). Parameter settings can be changed using the ProDriveNext.

7.1	Monitoring the data	7-1
7.2	Using the basic functions	7-6
7.3	Setting the intelligent I/O terminal function	7-12
7.4	Using the analog terminal	7-16
7.5	To drive the motor	7-20
7.6	Functions related to the operator display	7-45
7.7	Functions about restarting	7-51
7.8	Set functions related to protection and warning, each output signal	7-60
7.9	Initializing	7-77

7.1 Monitoring the data

7.1.1 Output frequency monitoring

When the output frequency monitoring function (d001) is selected, the inverter displays the output frequency. The inverter displays "0.00" when the frequency output is stopped.

The Hz monitor lamp lights up while the inverter is displaying the output frequency.

(Display)

0.00 to 99.99 in steps of 0.01 Hz

100.0 to 400.0 in steps of 0.1 Hz

Note: When you have selected the digital operator as the device to input frequency-setting commands (A001=02) and Data change mode selection (b163=01), you can change the output frequency setting by using the Δ and/or ∇ key (only while the inverter is operating the motor).

- The change in output frequency made in this mode can be reflected in the frequency setting (function "F001"). Press the STR key to write the new frequency over the currently selected frequency setting.
- You cannot change the output frequency while the PID function is enabled or the inverter is not operating the motor.
- When use UP/DWN function, please do not use it.

7.1.2 Output current monitoring

When the output current monitoring function (d002) is selected, the inverter displays the output current. The inverter displays "0.0" when the current output is stopped.

(Display)

0.0 to 655.3 in steps of 0.1 A

7.1.3 Rotation direction monitoring

When the rotation direction monitoring function (d003) is selected, the inverter displays the motor operation direction.

The RUN lamp lights up while the inverter is operating the motor (in forward or reverse direction).

(Display)

F: Forward operation

o: Motor stopped

r: Reverse operation

7.1.4 Process variable (PV), PID feedback monitoring

When "01" (enabling PID operation) or "02" (enabling inverted-data output) has been specified for function "A071" (PID Function Enable) and the process variable (PV), PID feedback monitoring function (d004) is selected, the inverter displays the PID feedback data.

You can also convert the PID feedback to gain data by setting a PV scale conversion (with function "A075").

Value displayed by function "d004" = "feedback quantity" (%) x " PV scale conversion (A075)"

The PV scale conversion can be set (by function "A075") within the range 0.01 to 99.99 in steps of 0.01.

(Display)

0.00 to 99.99 in steps of 0.01

100.0 to 999.9 in steps of 0.1

1000. to 9999. in steps of 1

1000 to 9999 in steps of 10

┌100 to ┌999 in units of 1000

Chapter 7 Explanation of Functions

7.1.5 Intelligent input terminal status

When the intelligent input terminal status function (d005) is selected, the inverter displays the states of the inputs to the intelligent input terminals.

The internal CPU of the inverter checks each intelligent input for significance, and the inverter displays active inputs as those in the ON state. (*1)

Intelligent input terminal status is independent of the a/b contact selection for the intelligent input terminals.

(Example)

Intelligent input terminals [2], and [1]: ON

Intelligent input terminals [5], [4], and [3]: OFF

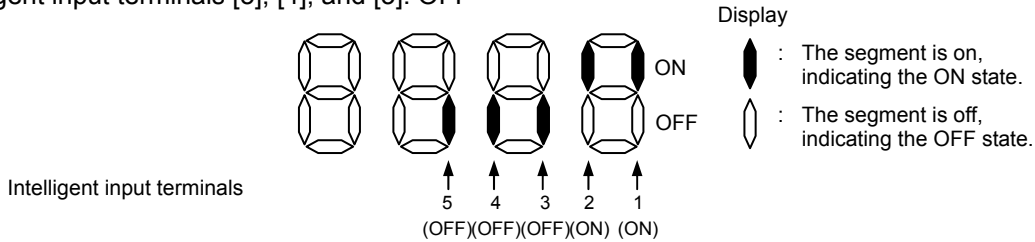

(*1)When input terminal response time is set, terminal recognition is delayed.

7.1.6 Intelligent output terminal status

When the intelligent output terminal status function (d006) is selected, the inverter displays the states of the outputs from the intelligent output terminals.

This function does not monitor the states of the control circuit terminals but monitors those of the outputs from the internal CPU.

Intelligent input terminal status is independent of the a/b contact selection for the intelligent input terminals.

(Example)

Intelligent output terminals [11]: ON

Alarm relay terminal AL : OFF

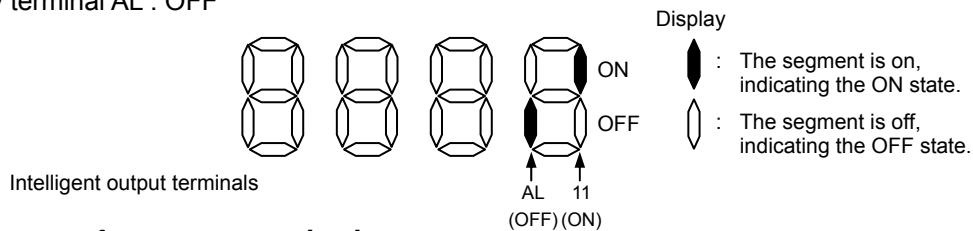

7.1.7 Scaled output frequency monitoring

When the scaled output frequency monitoring (d007) is selected, the inverter displays the gain data converted from the output frequency with the frequency scaling conversion factor (b086).

Use this function, for example, to change the unit of a value (e.g., motor speed) on display.

Value displayed by function "d007" = "output frequency monitor(d001)" x "frequency scaling conversion factor (b086)"

The frequency scaling conversion factor (b086) can be set within the range 0.01 to 99.99 in steps of 0.01.

(Example) Displaying the speed of a 4-pole motor

$$\text{Speed } N \text{ (min}^{-1}\text{)} = (120 \times f \text{ [Hz]})/\text{pole} = f \text{ (Hz)} \times 30$$

As the result of the above calculation with the factor (b086) set to 30.00, the inverter displays "1800" (60 x 30.0) when the output frequency is 60 Hz.

(Display)

0.00 to 99.99 in steps of 0.01

100.0 to 999.9 in steps of 0.1

1000. to 9999. in steps of 1

1000 to 3996 in units of 10

Note: When you have selected the digital operator as the device to input frequency-setting commands and Data change mode selection (b163=01), you can change the output frequency setting by using the Δ and/or ∇ key (only while the inverter is operating the motor).

- The change in output frequency made in this mode can be reflected in the frequency setting (function "F001"). Press the STR key to write the new frequency over the currently selected frequency setting. (The precision of the storable frequency data depends on the frequency setting.)
- You cannot change the output frequency while the PID function is enabled or the inverter is not operating the motor.
- When use UP/DWN function, please do not use it.

7.1.8 Output voltage monitoring

When the output voltage monitoring function (d013) is selected, the inverter displays the voltage output from the inverter.

(Display)

0.0 to 600.0 in steps of 0.1 V

(remark) Displayed value may not be accurate when the output voltage is differ from input voltage.

7.1.9 Input power monitoring

When the power monitoring function (d014) is selected, the inverter displays the electric power (momentary value) input to the inverter.

(Display)

0.0 to 999.9 in steps of 0.1 kW

7.1.10 Cumulative power monitoring

When the cumulative power monitoring function is selected, the inverter displays the cumulative value of electric power input to the inverter.

You can also convert the value to be displayed to gain data by setting the cumulative input power display gain setting (b079).

Value displayed by function "d015" = "calculated value of input power (kW/h)"/"cumulative input power display gain setting (b079)"

The cumulative power input gain can be set within the range 1 to 1000 in steps of 1.

You can clear the cumulative power data by specifying "01" for the cumulative power clearance function (b078) and pressing the STR key.

You can also clear the cumulative power data at an intelligent input terminal by assigning function "53" (KHC: cumulative power clearance) to the intelligent input terminal.

When the cumulative input power display gain setting (b079) is set to "1000", the cumulative power data up to 999000 (kW/h) can be displayed.

(Display)

0.0 to 999.9 in steps of 1 kW/h, or the unit set for function "b079"

1000 to 9999 in units of 10 kW/h, or the unit set for function "b079"

┌ 100 to ┌ 999 in units of 1000 kW/h, or the unit set for function "b079"

7.1.11 Cumulative operation RUN time monitoring

When the cumulative operation RUN time monitoring function (d016) is selected, the inverter displays the cumulative time of the inverter operation.

(Display)

0. to 9999. in units of 1 hour

1000 to 9999 in units of 10 hours

┌ 100 to ┌ 999 in units of 1,000 hours

7.1.12 Cumulative power-on time monitoring

When the cumulative power-on time monitoring function(d017) is selected, the inverter displays the cumulative time throughout which the inverter power has been on.

(Display)

0. to 9999. in units of 1 hour

1000 to 9999 in units of 10 hours

┌ 100 to ┌ 999 in units of 1,000 hours

7.1.13 Heat sink temperature monitoring

When the heat sink temperature monitoring function (d018) is selected, the inverter displays the temperature of the internal heat sink of the inverter.

(Display)

-20.0 to 150.0 in steps of 0.1 °C

Chapter 7 Explanation of Functions

7.1.14 Dual monitoring

Displays two different data configured in *b 160* and *b 161*.

Item	Func. code	Range of data	Description
Dual monitor	d050	—	Setting data of <i>b 160</i> and <i>b 161</i> .
1st parameter of Dual Monitor	b160	001~018	d001~d018 (*1)
2nd parameter of Dual Monitor	b161	001~018	d001~d018 (*1)

(*1) Excluding a Trip monitor 1 to 6(d081 to d086).

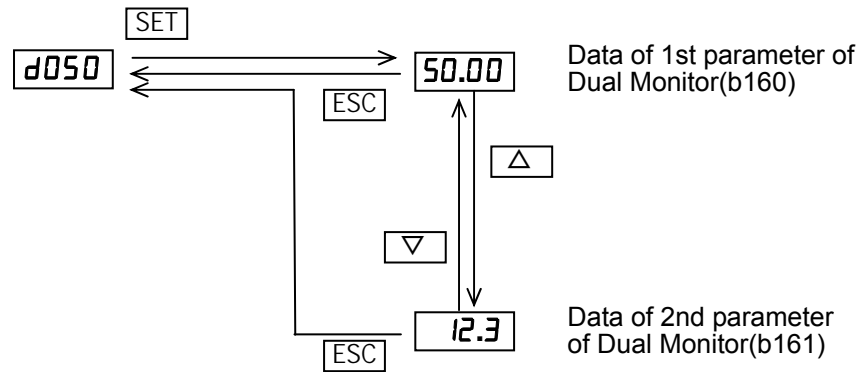

Note) If it enable the Frequency set in monitoring(*b 163=0 1*), (*d001*) and (*d007*) can change the output frequency as per $\Delta \nabla$ key in driving. But (*d050*) can not change (*d001*) and (*d007*).

7.1.15 Trip Counter

When the trip counter function (d080) is selected, the inverter displays the number of times the inverter has tripped.

(Display)

- 0. to 9999. in units of 1 trip
- 1000 to 6553 in units of 10 trips

7.1.16 Trip monitoring 1 to 6

When the trip monitoring function (d081 to d086) is selected, the inverter displays the trip history data. The last six protective trips the inverter made can be displayed.

Select the trip monitoring 1 (d081) to display the data on the most recent trip.

(Display contents)

- 1) Factor of tripping (one of E01 to E41) (*1)
- 2) Output frequency at tripping (Hz)
- 3) Output current at tripping (A) (*2)
- 4) Main circuit DC voltage at tripping (V) (*3)
- 5) Cumulative inverter-running time until tripping (h)
- 6) Cumulative inverter power-on time until tripping (h)

*1 See Chapter 9.

*2 When the inverter status is in stop mode as a trip history, monitored value can be zero.

*3 When grounding fault is detected at power on, monitored value can be zero.

(Display by trip monitoring)

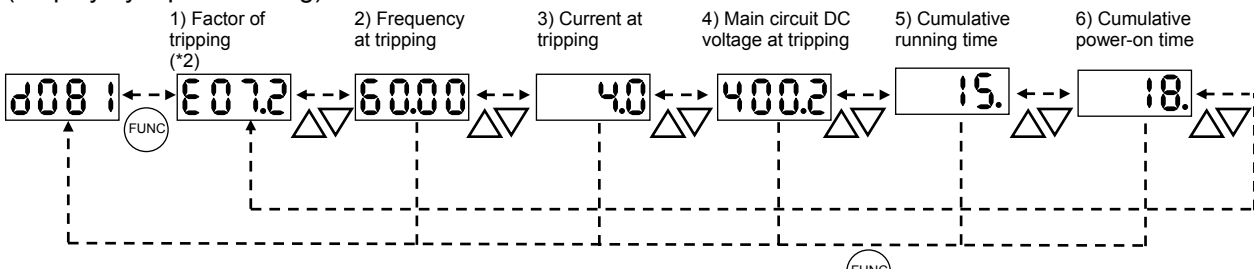

*2 If the inverter has not tripped before, the inverter displays .

7.1.17 Warning monitoring

If an attempt is made to set the data conflicting with other data on the inverter, the inverter displays a warning in the operator.

The PRG (program) lamp lights up while the warning is displayed (until the data is rewritten forcibly or corrected). For details on the programming error monitoring function, see Chapter 9.3 Warning Codes

7.1.18 DC voltage monitoring

When the DC voltage monitoring is selected, the inverter displays the DC voltage of the inverter.

While the inverter is operating, the monitored value changes as the actual DC voltage of the inverter changes.

(Display)

0.0 to 999.9 in steps of 0.1 V

7.1.19 Electronic thermal overload monitoring

When the electronic thermal overload monitoring function (d104) is selected, the inverter displays the electronic thermal overload. If the electronic thermal overload exceeds 100%, the inverter will trip because of the overload protection (error code "E05").

(Display)

0.0 to 100.0 in steps of 0.1%

IMPORTANT! Please be sure to set the motor nameplate data into appropriate parameters to ensure proper operation and protection of the motor.

*B012 is the motor overload protection value

*A082 is the motor voltage selection

*H003 is the motor kW capacity

*H004 is the number of motor poles

Please refer to the appropriate pages in this guide and the QRG for further details.

Chapter 7 Explanation of Functions

7.2 Using the basic functions

7.2.1 Frequency source setting and Output frequency setting

(1) Frequency source setting

The frequency source setting function allows you to select the method to input the frequency-setting command.

Item	Function code	Data	Description
Frequency source setting	A001 A201	00	(Valid only when the NES1-OP, OPE-SR/SRmini is used) Use the control provided on the digital operator to set the frequency.
		01	Input the frequency-setting command via a control circuit terminal (O/OI-L).
		02	Use the digital operator (function "F001") or remote operator to set the frequency.
		03	Input the frequency-setting command via a Modbus communication.
		10	Use the operation result of the set frequency operation function as the frequency-setting command.

(2) Output frequency setting

The output frequency setting function allows you to set the inverter output frequency.

You can set the inverter output frequency with this function (F001) only when you have specified "02" for the frequency source setting (A001).

(If the setting of function "A001" is other than "02", function "F001" operates as the frequency command monitoring function.)

The frequency set with function "F001" is automatically set as the Multispeed frequency setting (A020). To set the second and third multispeed s, use the multispeed frequency setting, 2nd motor, function (A220) and multispeed frequency setting, or use function "F001" for the setting after turning on the SET signal. For the setting using the SET signal, assign the SET function (08) to intelligent input terminals.

If the set output frequency is used as the target data for the PID function, PID feedback data will be displayed in percent (%). ("100%" indicates the maximum frequency.)

Item	Function code	Range of data	Description
Output frequency setting	F001	0.0, start frequency to maximum frequency, 1st/2nd motors (Hz)	The frequency set with F001 is equal to the setting of A020.
Multispeed 0	A020/A220		The second control frequency set with F001 is equal to the setting of A220.

7.2.2 Run command source setting

The run command source setting function allows you to select the method to input operation commands (to start and stop the motor).

As the operation commands via control circuit terminals, turn the FW signal (for forward operation) or RV signal (for reverse operation) on and off to start and stop the motor, respectively.

(Note that the factory setting assigns the FW signal to intelligent input terminal [1].)

To switch each intelligent input terminal between a and b contacts, specify each terminal with function "C011" to "C015", and then perform input a/b (NO/NC) selection for each terminal.

When using the digital operation for the inverter operation, specify the desired motor operation direction with function "F004", and use the RUN and STOP/RESET keys to start and stop the motor, respectively. If the start commands for both forward and reverse operations are input at the same time, the inverter will assume the input of a stop command.

Item	Function code	Data	Description
Run command source setting	A002 A202	01	Input the start and stop commands via control circuit terminals (FW and RV).
		02	Input the start and stop commands from the digital or remote operator.
		03	Input the start and stop commands via Modbus communication.
Terminal active state	C011 to C015	00	a (NO) contact
		01	b (NC) contact

Note 1: If function "31" (forcible operation) or "51" (forcible-operation terminal) is assigned to an intelligent input terminal, the settings made with functions "A001" and "A002" will be invalidated when the said intelligent input terminal is turned on and those methods to input frequency-setting and operation commands which are specified for the said terminal will be enabled.

Note 2: On the remote operator (WOP) being used to operate the inverter, pressing the REMT (remote) key enables you to input both frequency-setting and operation commands from the remote operator.

Note 3: RUN/STOP/RESET key of standard panel is valid regardless of the A002. However, when setting 3Wire functions is disabled.

7.2.3 Keypad Run key routing

When you enter operation commands via the digital operator, the Keypad Run key routing function allows you to select the direction of motor operation.

This function is ineffective when you use the control terminal block or remote operator to input operation commands.

Item	Function code	Data	Description
Keypad Run key routing	F004	00	Forward operation
		01	Reverse operation

7.2.4 Rotational direction restriction

The rotational direction restriction function allows you to restrict the direction of motor operation.

This function is effective regardless of the specification of operation command input device (e.g., control circuit block or digital operator).

If an operation command to drive the motor in a restricted direction is input, the inverter (digital operator) will display 0000.

Item	Function code	Data	Description
Rotational direction restriction	b035	00	Both forward and reverse operations are enabled.
		01	Only forward operation is enabled.
		02	Only reverse operation is enabled.

Chapter 7 Explanation of Functions

7.2.5 Stop mode selection

The stop mode selection function allows you to select one of two methods of stopping the motor when a stop command is input from the digital operator or via the control circuit terminal block. One is to decelerate the motor according to the specified deceleration time and then stop it; the other is to let the motor run freely until it stops.

If a start command is input while the motor is in free-running status, the inverter will restart the motor according to the setting of the restart mode after FRS (b088).

Item	Function code	Data	Description
Stop mode selection	b091	00	Normal stopping (stopping after deceleration)
		01	Free-running until stopping

7.2.6 Acceleration/deceleration time setting

- Specify a longer time for slower acceleration or deceleration; specify a shorter time for quicker acceleration or deceleration.
- The time set with this function is the time to accelerate (or decelerate) the motor from 0 Hz to the maximum frequency (or vice versa).
- To switch the acceleration and deceleration time among the 1st and 2nd settings, assign function "08" (SET) to intelligent input terminals . Use the SET signal for switching.

Item	Function code	Range of data	Description
Acceleration (1) time setting	F002/F202	0.00 to 3600.(s)	Set the length of time to accelerate the motor from 0 Hz to the maximum frequency.
Deceleration (1) time setting	F003/F203	0.00 to 3600.(s)	Set the length of time to decelerate the motor from the maximum frequency to 0 Hz.

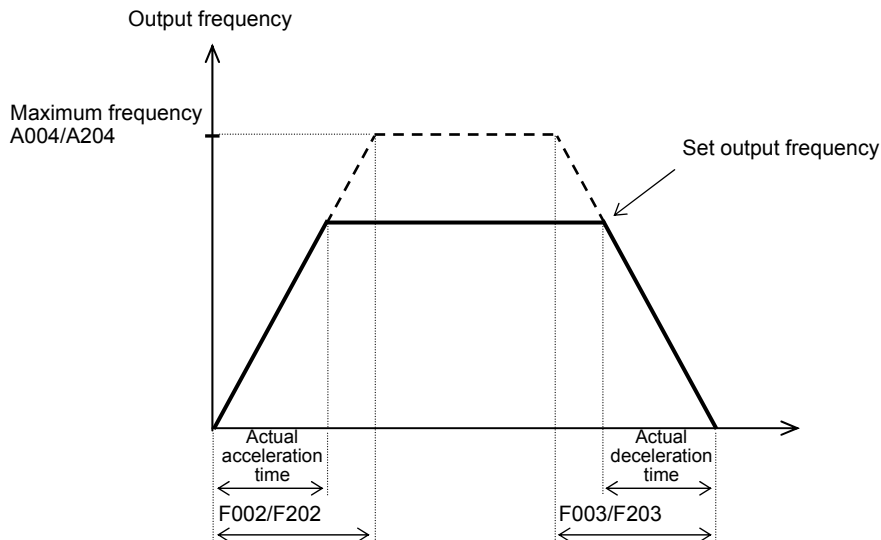

The actual time to accelerate/decelerate the motor will be no less than the minimum acceleration/deceleration time that depends on the inertial effect (J) due to the mechanical system and motor torque. If you set a time shorter than the minimum acceleration/deceleration time, the inverter may trip because of overcurrent or overvoltage.

Acceleration time (t_s)

$$t_s = \frac{(J_L + J_M) \times N_M}{9.55 \times (T_s - T_L)}$$

J_L : Inertia effect (J) of the load converted to that of the motor shaft ($\text{kg}\cdot\text{m}^2$)

J_M : Inertia effect (J) of the motor ($\text{kg}\cdot\text{m}^2$)

N_M : Motor speed (rpm)

T_s : Maximum acceleration torque driven by the inverter (N-m)

T_B : Maximum deceleration torque driven by the inverter (N-m)

T_L : Required running torque (N-m)

Deceleration time (t_B)

$$t_B = \frac{(J_L + J_M) \times N_M}{9.55 \times (T_B + T_L)}$$

7.2.7 Base frequency setting

(1) Base frequency and motor voltage

- With the base frequency setting and AVR voltage select functions, adjust the inverter outputs (frequency and voltage) to the motor ratings.
- The base frequency is the nominal frequency of the motor. Set a base frequency that meets the motor specification. Carefully note that setting the base frequency to less than 50 Hz may result in motor burnout.
- A special motor requires a base frequency of 60 Hz or more. Your inverter model may not be suitable for such a special motor, and one with a larger capacity may be required.
- Select the motor voltage that meets the motor specification. Selecting a motor voltage exceeding the motor specification may result in motor burnout.
- To switch the base frequency among the 1st and 2nd settings, assign function "08" (SET) to intelligent input terminals . Use the SET signal for switching.

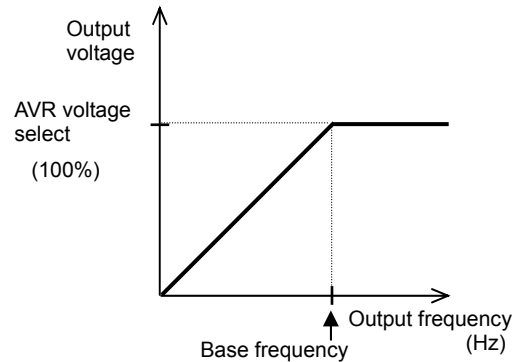

Item	Function code	Range of data	Description
Base frequency setting	A003/A203	30. to maximum frequency, 1st/2nd motors (Hz)	
AVR voltage select	A082/A282	200/215/220/230/240	Selectable on 200 V class inverter models
		380/400/415/440/460/480	Selectable on 400 V class inverter models

7.2.8 Using the AVR Functions

(1) What's the AVR function?

The AVR function maintains the correct voltage output to the motor, even when the voltage input to the inverter fluctuates. The output voltage maintained by this function is based on the voltage specified by the motor voltage select(A082/A282). But it can not exceed the receiving voltage. Use the AVR function select (A081/A281) to enable or disable the AVR function.

(2) AVR filter time constant and AVR deceleration gain

Motor acts as a generator during deceleration. Therefore, energy is regenerated to the inverter. As a result, the DC voltage of the inverter is increased. If DC voltage exceeds overvoltage level, the inverter is generated the overvoltage trip.

The higher the output voltage of the inverter, energy is consumed by the increasing loss of the motor. Therefore, it is possible to shorten the deceleration time. (However, the burden of the motor is increased.) In order to shorten the deceleration time without tripping the overvoltage,

1. Set A081 = 02.
2. Please tune voltage characteristics using the A084 and A083.

Chapter 7 Explanation of Functions

Item	Function code	Data	Description
AVR function select	A081/A281	00	The AVR function is always enabled.
		01	The AVR function is always disabled.
		02	The AVR function is disabled at deceleration. (*1)
AVR voltage select	A082/A282	200/215/220/230/240	Selectable on 200 V class inverter models
		380/400/415/440/460/480	Selectable on 400 V class inverter models
AVR filter time constant	A083	0.000~1.000 (s)	See diagram below. (*2)
AVR deceleration gain	A084	50.~200.(%)	See diagram below. (*2)

*1 Disabling the AVR function at motor deceleration increases the energy loss on the decelerated motor and decreases the energy regenerated on the inverter, which results in a shorter deceleration time.

*2 Operate regardless of the A081/A281.

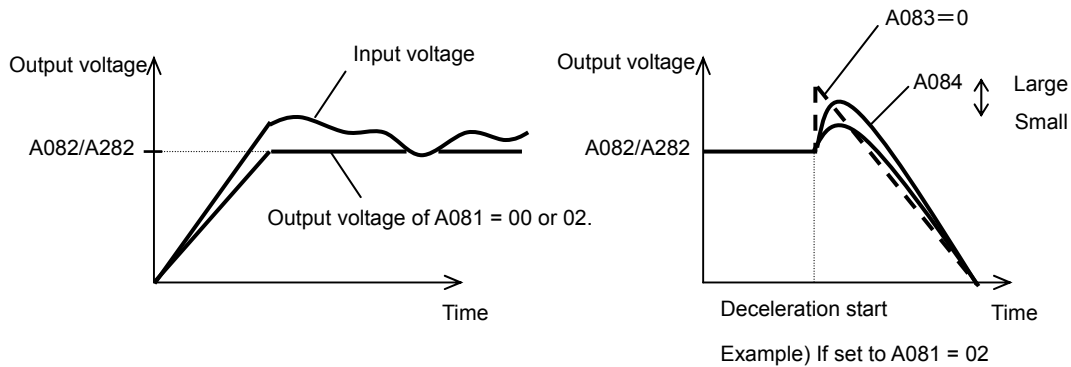

7.2.9 Maximum frequency setting

The maximum frequency setting function allows you to set the maximum frequency of the motor driven by the inverter. The maximum frequency set here corresponds to the maximum level of each external analog input (for example, 10 V of the input of 0 to 10 V). To switch the maximum frequency among the 1st and 2nd settings, assign function "08" (SET) to intelligent input terminals. Use the SET signal for switching. The inverter output voltage with the frequency ranging from the base frequency to the maximum frequency is that selected by the AVR voltage select function (A082/A282).

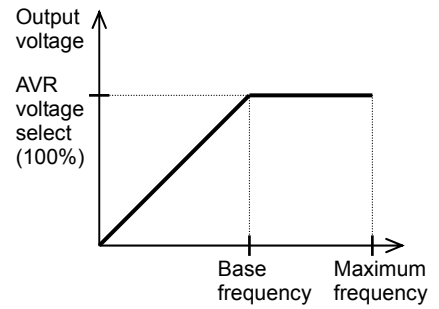

Item	Function code	Range of data	Description
Maximum frequency setting	A004/A204	base frequency 1st/2nd motors to 400. (Hz)	The maximum output frequency is set.

7.2.10 Carrier frequency setting

The carrier frequency setting function (b083) allows you to change the carrier frequency of the PWM waveform output from the inverter. Increasing the carrier frequency can lower the metallic noise from the motor, but may increase the inverter noise and current leakage. You can use this function effectively to avoid resonance of the mechanical system and motor.

Item	Function code	Range of data	Description
Carrier frequency setting	b083	2.0 to 15.0 (kHz)	

Note: When increasing the carrier frequency (fc), derate the output current as shown in the section 12.3.

Chapter 7 Explanation of Functions

7.3 Setting the intelligent I/O terminal function

7.3.1 Intelligent input terminal setting

You can assign the functions described below to intelligent input terminals [1] to [5]. To assign the desired functions to the terminals, specify the desired data listed in the table below for terminal settings "C001" to "C005". For example, "C001" corresponds to intelligent input terminal [1].

You can select the a-contact or b-contact input for individual intelligent input terminals.

You can assign one function only to an intelligent input terminal. If you have attempted to assign a function to two or more intelligent input terminals, the function is assigned to only the terminal to which you have last attempted assignment. Function data "NO" (no assign) is assigned to other terminals, and those terminals are ineffective in terms of functions.

After assigning the desired functions to intelligent input terminals [1] to [5], confirm that the assigned functions have been stored on the inverter.

Function code	Data	Description	Reference item	Page
C001 to C005	00	FW: Forward RUN command	Operation command	—
	01	RV: Reverse RUN command	Operation command	—
	02	CF1: Multispeed 1 setting (binary operation)	Multispeed operation function (Binary)	7-28
	03	CF2: Multispeed 2 setting (binary operation)		
	04	CF3: Multispeed 3 setting (binary operation)		
	06	JG: Jogging	Jogging operation function	7-25
	07	DB: External DC braking	DC braking (external DC braking) function	7-41
	08	SET: Set 2nd motor data	2nd motor control function	7-40
	09	2CH: 2-stage acceleration/deceleration	2-stage acceleration/deceleration function	7-29
	11	FRS: Free-run stop	Free-run stop function	7-56
	12	EXT: External trip	External trip function	7-66
	13	USP: Unattended start protection	Unattended start protection function	7-57
	15	SFT: Software lock (control circuit terminal block)	Software lock function	7-45
	18	RS: Reset	Reset	7-55
	20	STA: Starting by 3-wire input	3-wire input function	7-23
	21	STP: Stopping by 3-wire input		
	22	F/R: Forward/reverse switching by 3-wire input		
	23	PID: PID disable	PID function	7-34
	24	PIDC: PID reset		
	27	UP: Remote control UP function	Remote control (UP/DWN) function (bit)	7-32
	28	DWN: Remote control DOWN function		
	29	CLR: Remote control data clearing		
	31	OPE: Forcible operation	Forcible-operation function	7-45
	32	SF1: Multispeed 1 setting (bit operation)	Multispeed operation function	7-28
	33	SF2: Multispeed 2 setting (bit operation)		
	34	SF3: Multispeed 3 setting (bit operation)		
	39	OLR: Overload restriction selection	Overload restriction function	7-63
	50	ADD: Trigger for frequency addition (A145)	Frequency addition function	7-32
	51	F-TM: Forcible-terminal operation	Forcible-terminal operation function	7-46
	53	KHC: Cumulative power clearance	Cumulative power monitoring function	7-3
	65	AHD: Analog command holding	Analog command holding function	7-17
	83	HLD: Retain output frequency	Retain output frequency function	7-27
	84	ROK: Permission of Run command	Permission of Run command function	7-27
	86	DISP: Display limitation	Display limitation function	7-47
	no	NO: Allocation none	-	-

7.3.2 Input terminal a/b (NO/NC) selection

The input terminal a/b (NO/NC) selection function allows you to specify a-contact or b-contact input for each of the intelligent input terminals [1] to [5].

An a-contact turns on the input signal when closed and turns it off when opened.

An b-contact turns on the input signal when opened and turns it off when closed.

The terminal to which the reset (RS) function is assigned functions only as an a-contact.

Item	Function code	Data	Description
Terminal active state	C011 to C015	00	a-contact (NO)
		01	b-contact (NC)

7.3.3 Input terminal response time

- The input terminal response time function allows you to specify a sampling time for each of intelligent input terminals 1 to 5. You can use this function effectively to remove noise (e.g., chattering).
- If chattering hinders constant input from an input terminal, increase the response time setting for the input terminal. Note that an increase in response time deteriorates the response. The response time can be set in a range of about 2 to 400 ms (corresponding to settings of 0 to 200).

Item	Function code	Range of data	Description
Response time of intelligent input terminals 1 to 5	C160-C164	0. to 200.	Variable in step of 1

Note: When the power supply is OFF-> ON or reset , this function is invalid.

7.3.4 Intelligent output terminal setting

You can assign the functions described below to the intelligent output terminals [11] (C021) and the alarm relay terminal (C026).

The intelligent output terminals [11] is used for open-collector output, and the alarm relay terminal is used for relay output.

You can select the a-contact or b-contact output for individual output terminals by using functions "C031" and "C036".

Data	Description	Reference item	Page
00	RUN: Running signal	Running signal (RUN)	7-68
01	FA1: Constant-speed reached	Frequency-arrival signals	7-68
02	FA2: Set frequency overreached		
03	OL: Overload notice advance signal	Overload restriction/overload notice advance signal	7-63
04	OD: Output deviation for PID control	PID function	7-37
05	AL: Alarm signal	Protective functions	—
06	FA3: Set frequency reached	Frequency-arrival signals	7-68
09	UV: Undervoltage	undervoltage	7-53
11	RNT: Operation time over	Operation time over signal	7-70
12	ONT: Plug-in time over	Plug-in time over signal	7-70
13	THM: Thermal alarm signal	Electronic thermal protection	7-62
21	ZS: 0 Hz detection signal	0 Hz detection signal	7-70
27	Dc: Analog O/OI disconnection detection	Window comparators function	7-75
31	FBV: PID feedback comparison	PID function	7-34
32	NDc: Communication line disconnection	RS485	7-72
33	LOG1: Logical operation result 1	Logical operation function	7-71
41	FR: Starting contact signal	Starting contact signal	7-72
42	OHF: Heat sink overheat warning	Heat sink overheat warning	7-72
43	LOC: Low-current indication signal	Low-current indication signal	7-73
50	IRDY: Inverter ready	Inverter ready signal	7-73
51	FWR: Forward rotation	Forward rotation signal	7-73
52	RVR: Reverse rotation	Reverse rotation signal	7-74
53	MJA: Major failure	Major failure signal	7-74
54	WC:Window Comparator for Analog Voltage Input	Window comparators function	7-75
58	FREF:Frequency Command Source	Frequency Command Source signal	7-76
59	REF:Run Command Source	Run Command Source signal	7-76
60	SETM:2nd Motor Selection	2nd Motor Selection signal	7-76
no	NO: Allocation none		-

Chapter 7 Explanation of Functions

7.3. 5 Intelligent output terminal a/b (NO/NC) selection

The intelligent output terminal a/b (NO/NC) selection function allows you to specify a-contact or b-contact output for each of the intelligent output terminal [11] and the alarm relay terminal.

The intelligent output terminal [11] are used for open-collector output, and the alarm relay terminal is used for relay output.

Item	Function code	Data	Description
Terminal active state	C031	00	a-contact (NO)
		01	b-contact (NC)
Alarm relay active state	C036	00	a-contact (NO)
		01	b-contact (NC)

- An a-contact turns on the output signal when closed and turns it off when opened.

- A b-contact turns on the output signal when opened and turns it off when closed.

(1) Specifications of intelligent output terminal [11]

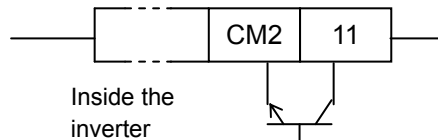

Setting of C031	Power supply	Output signal
00 (a-contact)	ON	OFF
	OFF	—
01 (b-contact)	ON	ON
	OFF	—

Electric characteristics
(Between terminal[11] and CM2)
Voltage drop when turned on: 4 V or less
Allowable maximum voltage: 27 VDC
Allowable maximum current: 50 mA

(2) Specifications of alarm relay terminal

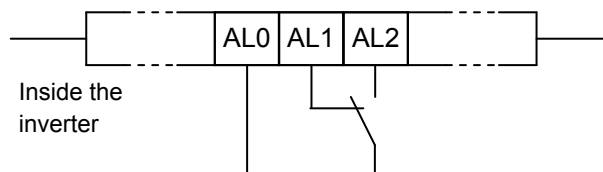

Example of operation as an alarm output terminal

Setting of C036	Power supply	Inverter status	Output terminal state			Resistance load		Inductive load	
			AL1-AL0	AL2-AL0					
00	ON	Error	Closed	Open	AL1-AL0	Maximum contact capacity	250 VAC, 2 A	250 VAC, 0.2 A	
		Normal	Open	Closed			30 VDC, 3 A	30 VDC, 0.6 A	
01 (default)	ON	—	Open	Closed	AL2-AL0	Minimum contact capacity	100 V AC, 10 mA		
		—	Open	Closed			5 VDC, 100 mA		
01 (default)	OFF	Error	Open	Closed	AL1-AL0	Maximum contact capacity	250 VAC, 1A	250 VAC, 0.2 A	
		Normal	Closed	Open			30 VDC, 1A	30 VDC, 0.2 A	
01 (default)	OFF	—	Open	Closed	AL2-AL0	Minimum contact capacity	100 VAC, 10 mA		
		—	Open	Closed			5 VDC, 100 mA		

7.3.6 Output signal delay/hold function

The output signal delay/hold function allows you to set on-delay and off-delay times for each output terminal.

Since every output signal is turned on or off immediately when the relevant condition is satisfied, signal chattering may occur if signal outputs conflict with each other. Use this function to avoid such a problem by holding or delaying specific signal outputs.

To use this function, set on-delay and off-delay times for individual output terminals (a total of two terminals, such as intelligent output terminals [11] and the alarm relay terminal).

Item	Function code	Range of data	Description
Output 11 on-delay time	C130	0.0 to 100.0 (s)	Setting of on fot terminal [11]
Output 11 off-delay time	C131	0.0 to 100.0 (s)	Setting of off for terminal [11]
Output RY on-delay time	C140	0.0 to 100.0 (s)	Setting of on fot relay terminal
Output RY off-delay time	C141	0.0 to 100.0 (s)	Setting of off for relay terminal

Chapter 7 Explanation of Functions

7.4 Using the analog terminal

7.4.1 Analog input (O/OI)

This inverter has an external analog input terminal.

If you want to switch the voltage and current inputs, use the switch on the board(SW6).

Voltage input : 0 to 10V (Variable resistor is a voltage input.)

Current input : 0 to 20mA (Please set the case of "4 to 20mA"to "A013=20%")

The analog input signal can be assigned the following functions.

Item	Function code	Data	Description
Frequency command	A001	01	01 : O/OI input
PID enable	A071	01(PID Enable) 02(PID Enable with reverse output)	
PV source	A076	01(O/OI)	

Example of wiring

Variable resistor
(1kΩ to 2kΩ)

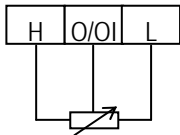

Voltage input
(0 to 10V)

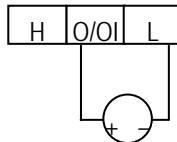

Current input
(0/4 to 20mA)

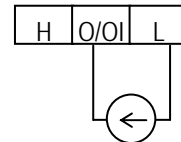

Please refer to section 3.2 about SW6 setting.

7.4.2 External analog input (O/OI) filter setting [A016]

The external analog input filter setting function allows you to set the input-voltage/input-current sampling time to be applied when frequency commands are input as external analog signals.

You can use this filter function effectively for removing noise from the frequency-setting circuit signal.

If the noise disables the stable operation of the inverter, increase the setting. Setting a larger value makes the inverter response slower. The filtering constant is "set value (1 to 30) x 2 ms."

When the setting is "31" (factory setting), a hysteresis of ±0.1 Hz is added to the filtering constant (500 ms).

Item	Function code	Range of data	Description
External frequency filter time const.	A016	1. to 30. or 31.	Setting of 1. to 30.: "Set value x 2" ms filter Setting of 31.: 500 ms filter (fixed) with hysteresis of ±0.1 Hz

7.4.3 Analog command holding function (AHD)

- The analog command holding function allows you to make the inverter hold the analog command input via the external analog input terminal when the AHD terminal is on.
- While the AHD terminal is on, the up/down function can be used based on the analog signal held by this function as reference data.
- When "01" is specified for Up/Down memory mode selection (C101), the result of up/down processing can be stored in memory.
- If the inverter power is turned on or the RS terminal turned off with the AHD terminal left turned on, the data held immediately before power-on or turning off the RS terminal will be used.

Item	Function code	Data	Description
Terminal [1] to [5] functions	C001 to C005	65	AHD: Analog command holding

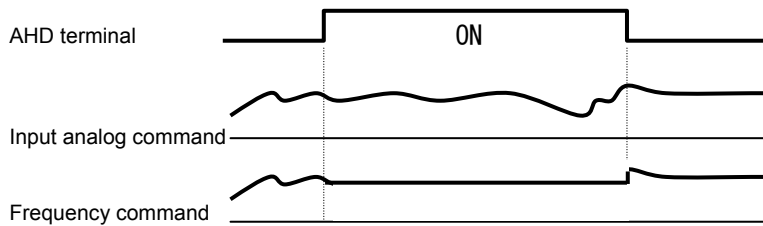

Note)
Set frequency remains when inverter is switched with SET terminal with AHD on. Turn AHD terminal off to re-hold the set frequency.

7.4.4 Analog Input Adjustment [C081/C082]

This function can change the gain of the analog input. Please use the fine adjustment of the analog input signal. Please refer to "7.4.5" for the scale transformation.

Item	Function code	Range of data	Description
O/OI input span calibration	C081	0. to 200.0(%)	This function will fine-tune the gain for the input voltage.

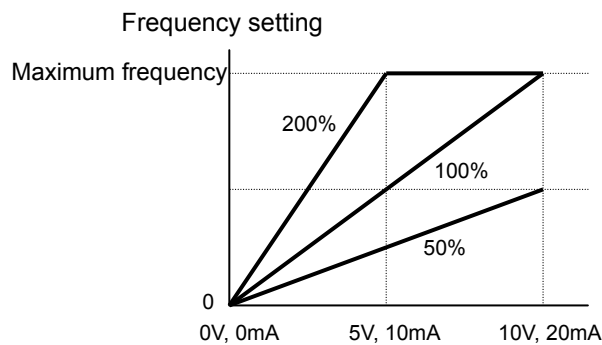

Chapter 7 Explanation of Functions

7.4.5 Start/end frequency setting for external analog input

The start/end frequency setting function allows you to set the inverter output frequency in relation to the external analog inputs (frequency commands) via the following terminals:

- O/OI-L terminal: 0 to 10 V or 0 to 20mA
- VR : volume of NES1-OP, OPE-SR/SRmini

(1) Start/end frequency settings for the O/OI-L terminals

Item	Function code	Range of data	Description
[O/OI]-[L] input /VR active range start frequency	A011/A161	0.00 to 400.0(Hz)	Setting of the start frequency
[O/OI]-[L] input /VR active range end frequency	A012/A162	0.00 to 400.0(Hz)	Setting of the end frequency
[O/OI]-[L] input /VR active range start voltage	A013/A163	0. to 100.(%)	Setting of the rate of the start frequency to the external frequency command (0 to 10 V/0 to 20 mA)
[O/OI]-[L] input /VR active range end voltage	A014/A164	0. to 100.(%)	Setting of the rate of the end frequency to the external frequency command (0 to 10 V/0 to 20 mA)
[O]/[OI]-[L] input start frequency enable	A015/A165	00	Externally input start frequency The frequency set as "A011/A161" is output as the output frequency while the start-frequency rate is 0% to the value set as "A013/A163".
		01	0 Hz 0 Hz is output as the output frequency while the start-frequency rate is 0% to the value set as "A013/A163".

If the voltage of the signal to be input to the O-L terminal is 0 to 5 V, specify 50% for "A014".

(Example 1) A015: 00

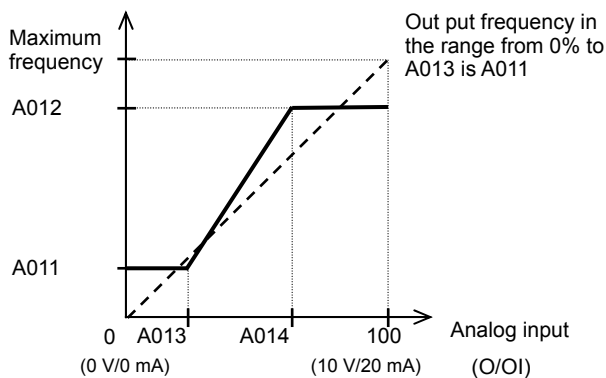

(Example 2) A015: 01

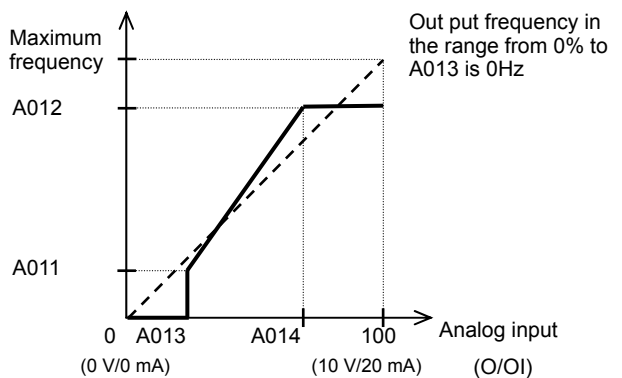

7.4.6 FM terminal [C027]

You can monitor the inverter output frequency and output current via the FM terminal on the control circuit terminal block. The FM terminal is a pulse output terminal.

(1) FM signal selection

Select the signal to be output from the FM terminal among those shown below.

If you select "03" (digital output frequency) or "08" (Digital current monitoring), connect a digital frequency counter to the FM terminal. To monitor other output signals, use an analog meter.

Item	Data	Description	Full-scale value
C027	00	Output frequency (See example 1.)	0 to maximum frequency (Hz)
	01	Output current (See example 1.)	0 to 200%
	03	Digital output frequency (See example 2.) *1)	0 to maximum frequency (Hz)
	04	Output voltage (See example 1.)	0 to 133% (75% of full scale is equivalent to 100%)
	05	Input power (See example 1.)	0 to 200%
	06	Electronic thermal overload (See example 1.)	0 to 100%
	07	LAD frequency (See example 1.)	0 to maximum frequency (Hz)
	08	Digital current monitoring (See example 2.)	Refer to (3)
	10	Heat sink temperature (See example 1.)	0°C to 200°C (0°C is output when the motor temperature is 0°C or less.)

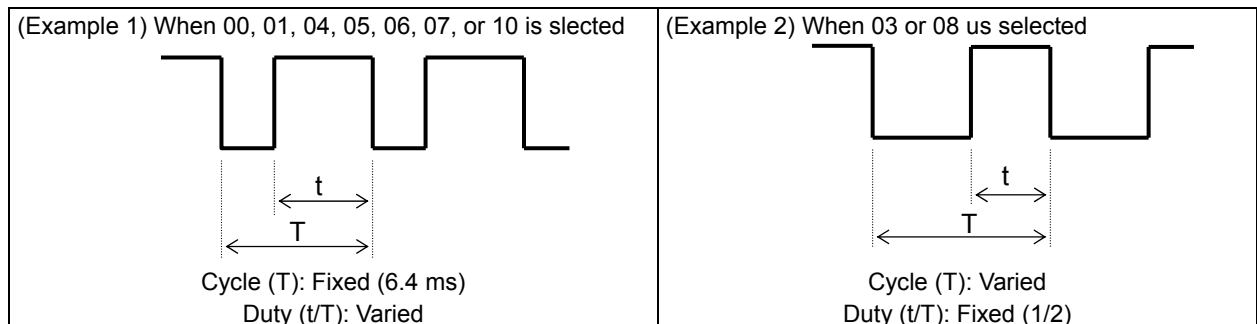

*1) In case of C027=03, when b086 (frequency scaling conversion factor) is set, the value converted by gain is displayed.

(2) FM terminal analog meter adjustment

Adjust the inverter output gain for the external meter connected to the FM terminal.

Item	Function code	Range of data	Description
[FM] terminal analog meter adjustment for "C027 = 00,01,04,05,06,07,10"	C105	50. to 200. (%)	Setting of the gain for FM monitoring

(3) Digital current monitoring

If the output current matches the digital current monitor reference value (C030), the FM terminal will output a signal indicating 1,440 Hz.

Item	Function code	Range of data	Description
Digital current monitor reference value	C030	"0.2 x rated current" to "2.0 x rated current" (A)	Setting of the current for 1,440 Hz output

Chapter 7 Explanation of Functions

7.5 To drive the motor

7.5.1 V/f characteristic curve selection [A044/A244]

The V/F characteristic curve selection function allows you to set the output voltage/output frequency (V/f) characteristic.

To switch the V/F characteristic curve selection among the 1st and 2nd settings, assign function "08" (SET) to intelligent input terminals. Use the SET signal for switching.

Function code	Data	V/f characteristic	Remarks
A044/A244	00	Constant torque characteristic (VC)	
	01	Reduced-torque characteristic (1.7th power of VP)	
	02	Free V/f characteristic	

(1) Constant torque characteristic (VC)

With this control system set, the output voltage is in proportion to the output frequency within the range from 0 Hz to the base frequency. Within the output frequency range over the base frequency up to the maximum frequency, the output voltage is constant, regardless of the change in the output frequency.

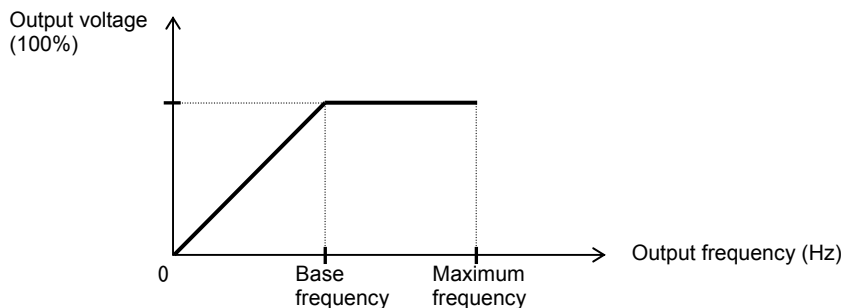

(2) Reduced-torque characteristic (1.7th power of VP)

This control system is suited when the inverter is used with equipment (e.g., fan or pump) that does not require a large torque at a low speed.

Since this control system reduces the output voltage at low frequencies, you can use it to increase the efficiency of equipment operation and reduce the noise and vibrations generated from the equipment. The V/f characteristic curve for this control system is shown below.

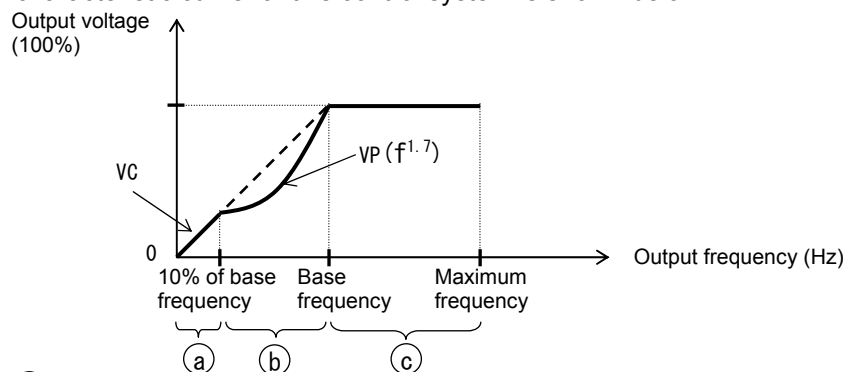

- Period (a) : While the output frequency increases from 0 Hz to the 10% of the base frequency, the output voltage follows the constant torque characteristic.
(Example) If the base frequency is 60 Hz, the constant torque characteristic is maintained within the output frequency range of 0 to 6 Hz.
- Period (b) : While the output frequency increases from the 10% of base frequency to the base frequency, the output voltage follows the reduced-torque characteristic. In other words, the output voltage increases according to the 1.7th power of the output frequency.
- Period (c) : While the output frequency increases from the base frequency to the maximum frequency, the output voltage is constant.

(3) Free V/f characteristic setting

The free V/f characteristic setting function allows you to set an arbitrary V/f characteristic by specifying the voltages and frequencies (b100 to b113) for the seven points on the V/f characteristic curve.

The free V/f frequencies (1 to 7) set by this function must always be in the collating sequence of "1 ≤ 2 ≤ 3 ≤ 4 ≤ 5 ≤ 6 ≤ 7".

Since all free V/f frequencies are set to 0 Hz as default (factory setting), specify their arbitrary values (begin setting with free-setting V/f frequency (7)). (The inverter cannot operate with the free V/f characteristic in the factory setting.)

Enabling the free V/f characteristic setting function disables the torque boost selection (A041/A241), base frequency setting (A003/A203), and maximum frequency setting (A004/A204). (The inverter assumes the value of free-setting V/f frequency (7) as the maximum frequency.)

Item	Function code	Data	Description
Free-setting V/f frequency (7)	b112	0 to 400.(Hz)	Setting of the output frequency at each breakpoint of the V/f characteristic curve
Free-setting V/f frequency (6)	b110	0. to free-setting V/f frequency (7) (Hz)	
Free-setting V/f frequency (5)	b108	0. to free-setting V/f frequency (6) (Hz)	
Free-setting V/f frequency (4)	b106	0. to free-setting V/f frequency (5) (Hz)	
Free-setting V/f frequency (3)	b104	0. to free-setting V/f frequency (4) (Hz)	
Free-setting V/f frequency (2)	b102	0. to free-setting V/f frequency (3) (Hz)	
Free-setting V/f frequency (1)	b100	0. to free-setting V/f frequency (2) (Hz)	
Free-setting V/f voltage (7)	b113	0.0 to 300.0(V) :Selectable on 200 V class inverter models	Setting of the output voltage at each breakpoint of the V/f characteristic curve (*1)
Free-setting V/f voltage (6)	b111		
Free-setting V/f voltage (5)	b109	0.0 to 600.0(V) :Selectable on 400 V class inverter models	
Free-setting V/f voltage (4)	b107		
Free-setting V/f voltage (3)	b105		
Free-setting V/f voltage (2)	b103		
Free-setting V/f voltage (1)	b101		

(Example)

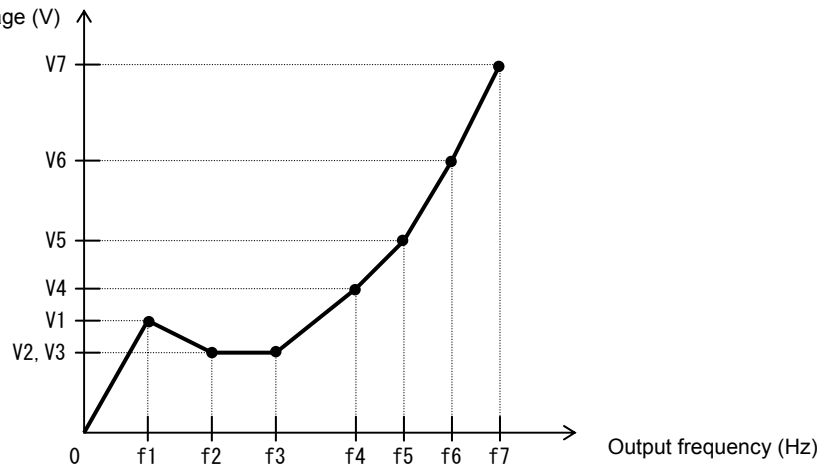

*1 Even if 300 V is set as a free-setting V/f voltage (1 to 7), the inverter output voltage cannot exceed the inverter input voltage or that specified by the AVR voltage select.

Carefully note that selecting an inappropriate control system (V/f characteristic) may result in overcurrent during motor acceleration or deceleration or vibration of the motor or other machine driven by the inverter.

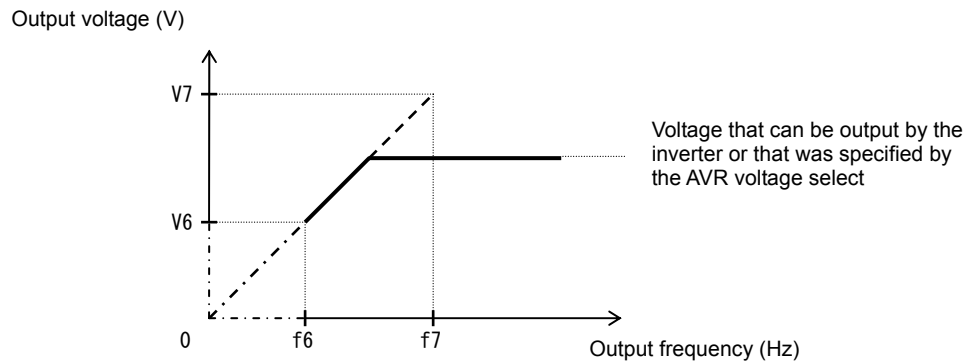

Chapter 7 Explanation of Functions

7.5.2 Torque boost setting

The torque boost setting function allows you to compensate for the voltage drop due to wiring and the primary resistance of the motor so as to improve the motor torque at low speeds.

When you select automatic torque boost by the torque boost selection (A041/A241), adjust the settings of the motor capacity selection (H003/H203) and motor pole selection (H004/H204) based on the motor to be driven.

Item	Function code	Data or range of data	Description
Torque boost selection	A041/A241	00	Manual torque boost
		01	Automatic torque boost
Manual torque boost value	A042/A242	0.0 to 20.0(%)	Setting of the rate of the boost to the AVR voltage (A082/A282)
Manual torque boost frequency adjustment	A043/A243	0.0 to 50.0(%)	Setting of the rate of the frequency at breakpoint to the base frequency (A003/A203)
Motor capacity	H003/H203	0.1 to 5.5(kW)	Selection of the motor capacity
Motor poles setting	H004/H204	2, 4, 6, 8 (poles)	Selection of the number of poles of the motor
Voltage compensation gain setting for automatic torque boost	A046/A246	0. to 255.	See Item (2), "Automatic torque boost."
Slippage compensation gain setting for automatic torque boost	A047/A247	0. to 255.	See Item (2), "Automatic torque boost."

(1) Manual torque boost

The inverter outputs the voltage according to the settings of the manual torque boost (A042/A242) and manual torque boost frequency adjustment (A043/A243).

Use the manual torque boost value (A042/A242) to specify the rate of the boost to the voltage (100%) set by the AVR voltage select.

When increasing the value of the manual torque boost value, be careful to prevent motor over-excitation. Over-excitation may result in motor burnout.

Use the manual torque boost frequency adjustment (A043/A243) to specify the rate of the frequency at each breakpoint to the base frequency (100%).

To switch the settings among the 1st and 2nd settings ("A041 to A043" and "A241 to A243"), assign function "08" (SET) to intelligent input terminals. Use the SET signal for switching.

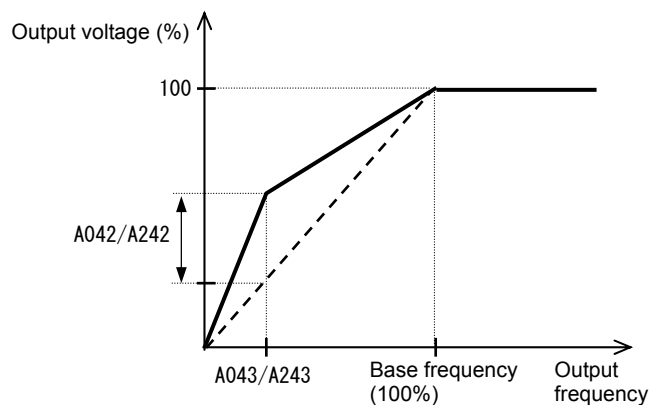

(2) Automatic torque boost

When automatic torque boost (data "01") is selected by the torque boost selection (A041/A241), the inverter automatically adjusts the output frequency and voltage according to the load on the motor. (During actual operation, the automatic torque boost is usually combined with the manual torque boost.)

When you select the automatic torque boost, adjust the settings of the motor capacity selection (H003/H203) and motor pole selection (H004/H204) according to the motor to be driven.

If the inverter trips due to overcurrent during motor deceleration, set the AVR function select (A081) to always enable the AVR function (data "00").

If you cannot obtain the desired operation characteristic by using the automatic torque boost, make the following adjustments:

Symptom	Adjustment method	Adjustment item
Motor torque is insufficient at low speed. (The motor does not rotate at low speed.)	(1) Increase the voltage setting for manual torque boost step by step.	A042/A242
	(2) Increase the slippage compensation gain for automatic torque boost step by step.	A047/A247
	(3) Increase the voltage compensation gain for automatic torque boost step by step.	A046/A246
	(4) Reduce the carrier frequency setting.	b083
The motor speed falls when a load is applied to the motor.	Increase the slippage compensation gain for the automatic torque boost step by step.	A047/A247
The motor speed increases when a load is applied to the motor.	Reduce the slippage compensation gain for the automatic torque boost step by step.	A047/A247
The inverter trips due to overcurrent when a load is applied to the motor.	(1) Reduce the voltage compensation gain for the automatic torque boost step by step.	A046/A246
	(2) Reduce the slippage compensation gain for the automatic torque boost step by step.	A047/A247
	(3) Reduce the voltage setting for the manual torque boost step by step.	A042/A242

7.5.3 3-wire interface operation function (STA, STP, and F/R)

The 3-wire interface operation function allows you to use automatic- reset contacts (e.g., pushbutton switches) to start and stop the inverter.

Specify "01" (control circuit terminal block) for the run command source setting (A002).

Assign function "20" (STA), "21" (STP), and "22" (F/R) to three of the terminal [1] to [5] functions (C001 to C005) to enable the control operations described below. Assigning the STP function to an intelligent input terminal disables the functions of the FW and RV terminals.

While the (STP) is OFF, the (STA) is invalid.

Item	Function code	Data	Description
Terminal [1] to [5] functions	C001 to C005	20	STA: Starting the motor
		21	STP: Stopping the motor
		22	F/R: Switching the motor operation direction

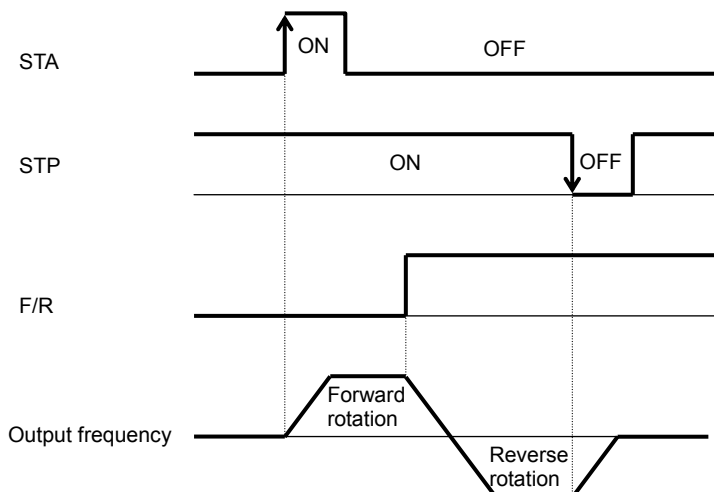

Note : In 3 wire input , STP input is used at the b point of contact. But the setting of STP is the a point of contact..

Chapter 7 Explanation of Functions

7.5.4 Start frequency setting

The start frequency setting function allows you to specify the inverter output frequency that the inverter initially outputs when an operation command is input.

Use this function mainly to adjust the start torque.

If the start frequency (b082) is set too high, the inverter will start the motor with a full voltage, which will increase the start current. Such status may trigger the overload restriction operation or make the inverter prone to easily tripping because of the overcurrent protection.

Item	Function code	Range of data	Description
Start frequency adjustment	b082	0.01 to 9.99 (Hz)	Setting of the start frequency

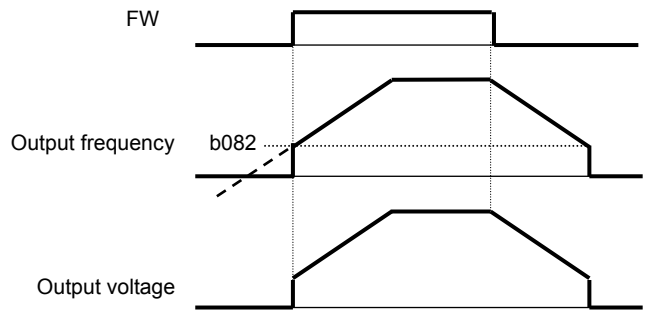

7.5.5 Reduced voltage start function

The reduced voltage start function enables you to make the inverter increase the output voltage gradually when starting the motor.

Set a small value for the reduced voltage start selection (b036) if you intend to increase the start torque.

On the other hand, setting a small value will cause the inverter to perform full-voltage starting and to easily trip because of overcurrent.

Item	Function code	Range of data	Description
Reduced voltage start selection	b036	00	Disabling the reduced voltage starting
		01 to 250	01: Short (about 4 ms) ↕ 250: Long (about 1000ms)

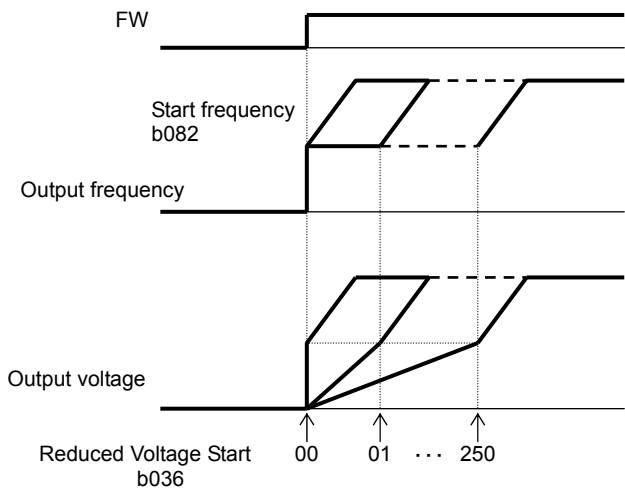

7.5.6 Jogging (JG) command setting

The jogging command setting function allows you to set and finely tune the motor-stopping position. To use this function, assign function "06" (JG) to an intelligent input terminal.

(1) Jog frequency setting

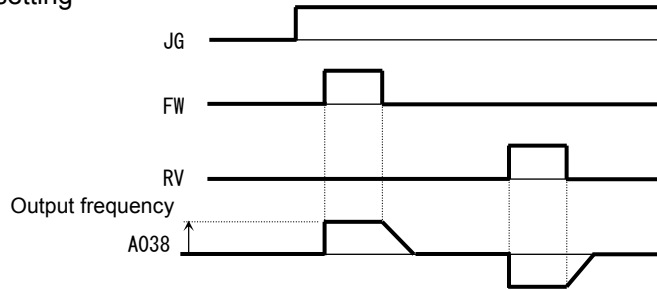

Since the inverter operates the motor with a full voltage for the jogging operation, the inverter can easily trip during the latter. Adjust the jog frequency setting (A038) properly so that the inverter will not trip.

Item	Function code	Range of data	Description
Jog frequency setting	A038	"start frequency" to 9.99 (Hz)	Setting of the frequency to output during jogging operation

(2) Jog stop mode

Item	Function code	Data	Description
Jog stop mode	A039	00	Disabling jogging while the motor is operating and enabling free-running when the motor is stopped
		01	Disabling jogging while the motor is operating and enabling stopping after deceleration when the motor is stopped
		02 (See Note 2.)	Disabling jogging while the motor is operating and enabling DC braking when the motor is stopped
		03	Enabling jogging while the motor is operating and enabling free-running when the motor is stopped
		04	Enabling jogging while the motor is operating and enabling stopping after deceleration when the motor is stopped
		05 (See Note 2.)	Enabling jogging while the motor is operating and enabling DC braking when the motor is stopped

Note 1: To perform the jogging operation, always turn on the JG terminal before turning on the FW or RV terminals. (Follow this sequence of command inputs also when using the digital operator to enter operation commands.)

Note 2: You must set DC braking data if you specify "02" or "05" for the jog stop mode (A039).

(Example 1)

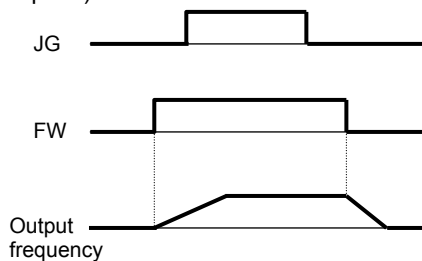

When "00", "01", or "02" is specified for the jog stop mode (A039), the jogging operation will not be performed if the FW signal is turned on earlier than the JG signal.

(Example 2)

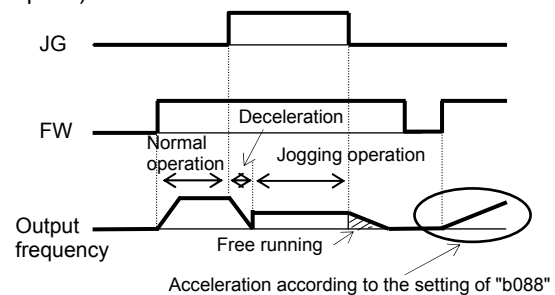

When "03", "04", or "05" is specified for the jog stop mode (A039), the jogging operation will be performed, even if the FW signal is turned on earlier than the JG signal. However, the motor will stop after free-running if the JG signal is turned off earlier than the FW signal.

Chapter 7 Explanation of Functions

7.5.7 Frequency upper limit setting

The frequency upper limit setting function allows you to place upper and lower limits on the inverter set frequency.

This function restricts the input of frequency commands that specify any frequencies outside the upper and lower limits.

When use PID function, limits the PID-output.

Always set the upper limit before setting the lower limit. Also, be sure to keep the frequency upper limit (A061/A261) larger than the frequency lower limit (A062/A262).

Be sure that upper limit/lower limit does not exceed Maximum frequency (A004/A204).

Be sure to set output frequency (F001) and multiple speed 1 to 7(A021 to A027) in between upper limit and lower limit.

If 0 Hz is set for the frequency upper and lower limits, they will not operate.

Item	Function code	Range of data	Description
Frequency upper limit setting	A061/A261	0.00 or a frequency more than the frequency lower limit setting up to the maximum frequency (Hz)	Setting of the upper limit of the set frequency
Frequency lower limit setting	A062/A262	0.00 or a frequency not less than the starting frequency up to the frequency upper limit setting (Hz)	Setting of the lower limit of the set frequency

When the O/OI-L terminal is used:

Output frequency (Hz)

Maximum frequency
A004/A204

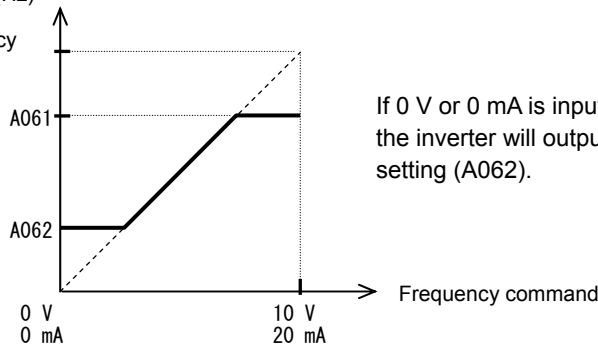

7.5.8 Jump frequency function

The jump frequency function allows you to operate the inverter so that it avoids the resonant frequency of the machine driven by the same.

Since the inverter avoids the motor operation with a constant output frequency within the specified range of the frequencies to jump when the jump frequency function is enabled, you cannot set any inverter output frequency within the specified range of the frequencies to jump.

Note that, while the inverter is accelerating or decelerating the motor, the inverter output frequency changes continuously according to the set acceleration/deceleration time.

You can set up to three frequencies to jump.

Item	Function code	Range of data	Description
Jump (center) frequency settings, 1st/2nd/3rd settings	A063/A065/ A067	0.00 to 400.0 (Hz) (*1)	Setting of the center frequency of the frequency range to be jumped
Jump (hysteresis) frequency width settings, 1st/2nd/3rd settings	A064/A066/ A068	0.00 to 10.00(Hz)	Setting of the half bandwidth of the frequency range to be jumped

*1 Setting of 0 Hz disables the jump frequency function.

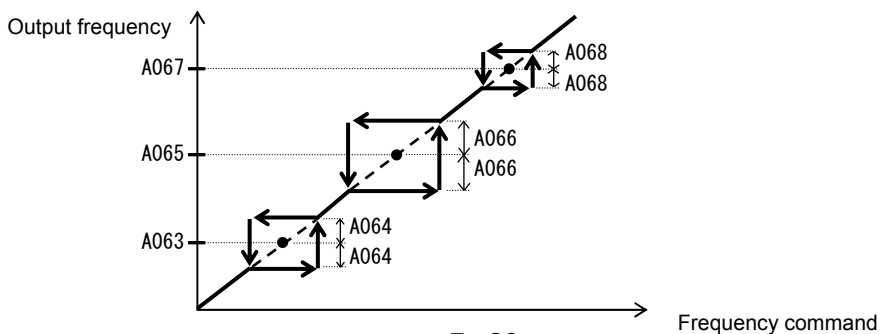

7.5.9 Acceleration/Deceleration hold frequency setting

The acceleration/deceleration hold frequency setting function allows you to make the inverter wait, upon starting the motor, until the slipping of the motor becomes less when the load on the motor causes a large moment of inertia.

Use this function if the inverter has tripped because of overcurrent when starting the motor.

This function can operate with every acceleration/deceleration pattern, regardless of the setting of the acceleration/deceleration curve selection (A097/A098).

The method of this function has following two ways and can use both together.

- by the setting parameter (A069,A070,A154,A155)
- by terminal function (HLD)

Item	Function code	Range of data	Description
Acceleration hold frequency setting	A069	0.00 to 400.0(Hz)	Setting of the frequency at which to stop acceleration
Acceleration hold time setting	A070	0.0 to 60.0(s)	Setting of the length of time to stop acceleration
Deceleration hold frequency setting	A154	0.00 to 400.0(Hz)	Setting of the frequency at which to stop deceleration
Deceleration hold time setting	A155	0.0 to 60.0(s)	Setting of the length of time to stop deceleration
Terminal function	C001 to C005	83	HLD : Retain output frequency function

- 1) by the setting parameter (A069,A070,A154,A155) 2) by terminal function (HLD)

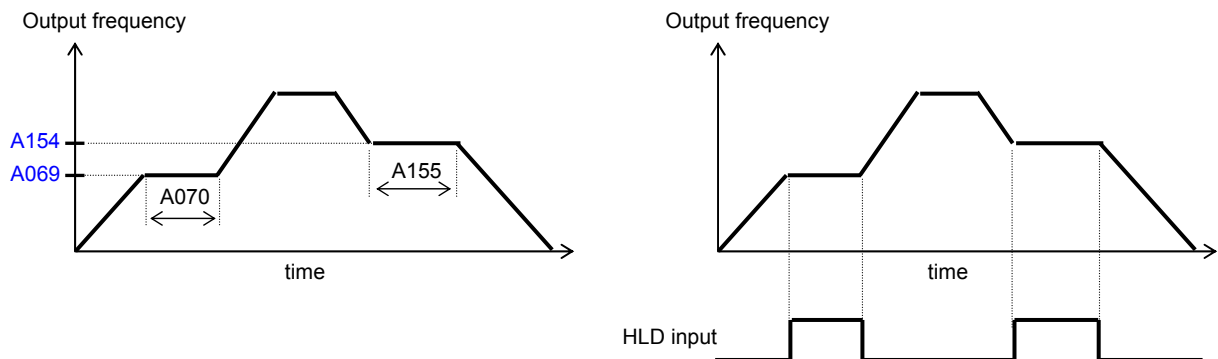

7.5.10 Permission of Run command function (ROK)

While the (ROK) input is ON , the run command is valid.

To use this function, assign function "84" (ROK) to one of the terminal [1] to [5] functions (C001 to C005).

Item	Function code	Data	Description
Terminal [1] to [5] functions	C001 to C005	84	ROK: Permission of Run command function

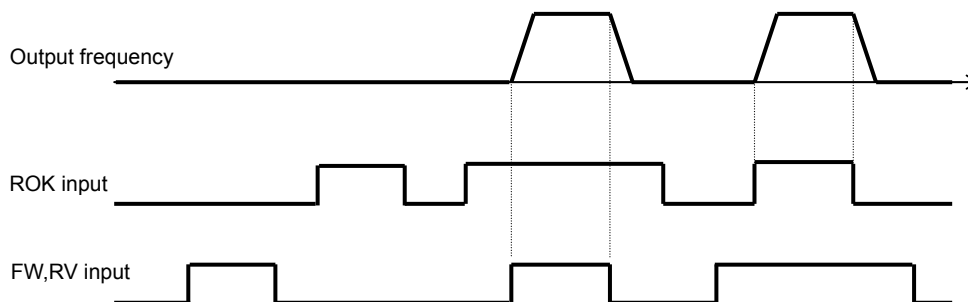

Chapter 7 Explanation of Functions

7.5.11 Multispeed select setting (CF1 to CF3 and SF1 to SF3)

The multispeed select setting function allows you to set multiple motor speeds and switch among them by way of signal input via specified terminals.

Multispeed operation can be performed in two modes: binary operation mode (with up to 8 speeds) using three input terminals and bit operation mode (with up to 4 speeds) using three input terminals.

Item	Function code	Data	Description
Multispeed operation selection	A019	00	Binary operation mode with up to 8 speeds
		01	Bit operation mode with up to 4 speeds
Multispeed 0 to 7 settings	A020/A220 A021 to A027	0.00 or "start frequency" to "maximum frequency" (Hz)	Setting of the frequency as each speed

(1) Binary operation mode

Assign functions "02" (CF1) to "04" (CF3) individually to the terminal [1] to [5] functions (C001 to C005) to make multispeeds 0 to 7 available for selection.

Specify the desired frequencies for speeds 1 to 7 by setting multispeeds 1 to 7 (A021 to A027).

You can set speed 0 by using function "A020", "A220" or "F001" when you have specified the digital operator for the frequency source setting. You can set speed 0 by using the O/OI terminal when you have specified the control circuit board for the frequency source setting.

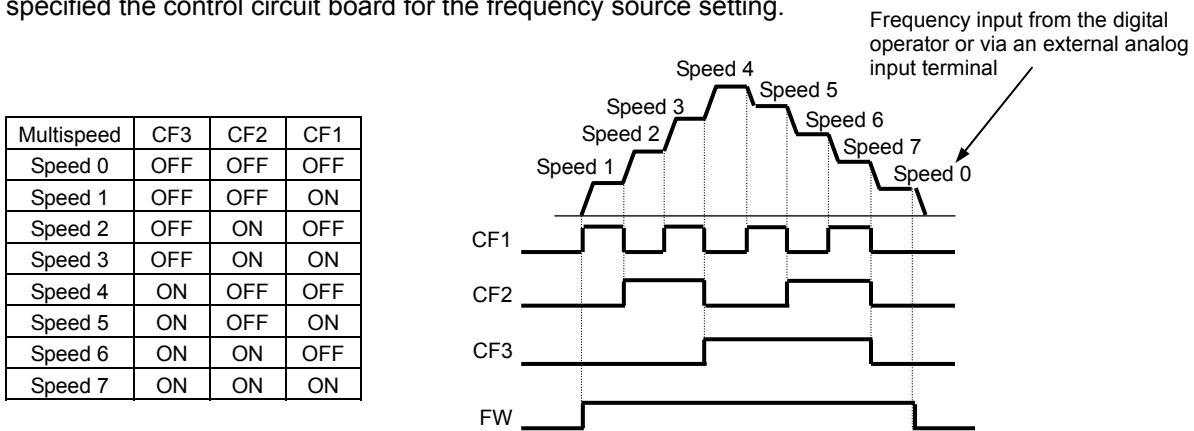

- With multispeed binary operation mode, you can use the multistage speed determination time setting (C169) to specify a delay to be set until the relevant terminal input is determined. (time = C169*10ms)
Use this specification to prevent the application of fluctuating terminal input before it is determined.

- The input data is finally determined when terminal input becomes stable after the delay set as C169. (Note that a long determination time deteriorates the input terminal response.)

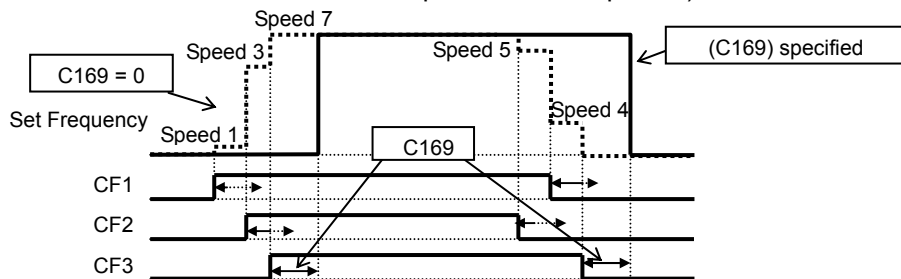

(2) Bit operation mode

- Assign functions "32" (SF1) to "34" (SF3) individually to the terminal [1] to [5] functions (C001 to C005) to make multispeeds 0 to 3 available for selection.

- Specify the desired frequencies for speeds 1 to 3 (SF1 to SF3) by setting multispeeds 1 to 3 (A021 to A023).

Multispeed	SF3	SF2	SF1
Speed 0	OFF	OFF	OFF
Speed 1	x	x	ON
Speed 2	x	ON	OFF
Speed 3	ON	OFF	OFF

If two or more input terminals are turned on at the same time, the terminal given the smallest terminal number among them has priority over others. The "X" mark in the above table indicates that the speed can be selected, regardless of whether or not the corresponding terminal is turned on.

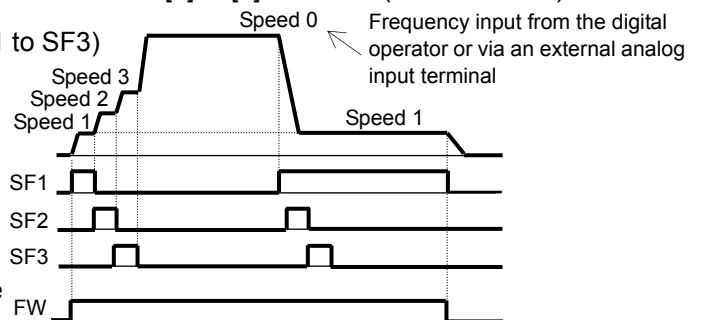

7.5.12 Two-stage acceleration/deceleration function (2CH)

The two-stage acceleration/deceleration function allows you to change the acceleration or deceleration time while the inverter is accelerating or decelerating the motor.

Select one of the following three methods of changing the acceleration or deceleration time:

- 1) Changing the time by the signal input to an intelligent input terminal
- 2) Automatically changing the time when the output frequency reaches a specified frequency
- 3) Automatically changing the time only when switching the motor operation from forward rotation to reverse rotation, or vice versa

To change the acceleration/deceleration time by the signal input to an intelligent input terminal, assign function "09" (2CH) to one of the terminal functions C001 to C005.

Item	Function code	Data	Description
Acceleration (2) time setting	A092/A292	0.00 to 3600. (s)	(See examples 1 and 2.)
Deceleration (2) time setting	A093/A293	0.00 to 3600. (s)	(See examples 1 and 2.)
Select method to switch to Acc2/Dec2 profile	A094/A294	00	Changing the time by the signal input to the 2CH terminal (See example 1.)
		01	Changing the time at the two-stage acceleration/deceleration frequency (See example 2.)
		02	Valid only while the inverter is switching the motor between forward and reverse operations (See example 3.)
Acc1 to Acc2 frequency transition point	A095/A295	0.00 to 400.0 (Hz)	Valid when "01" is specified for the select method to switch to Acc2/Dec2 profile (A094/A294) (See example 2.)
Dec2 to Dec1 frequency transition point	A096/A296	0.00 to 400.0 (Hz)	Valid when "01" is specified for the Select method to switch to Acc2/Dec2 profile (A094/A294) (See example 2.)

(Example 1) When "00" is specified for "A094" or "A294"

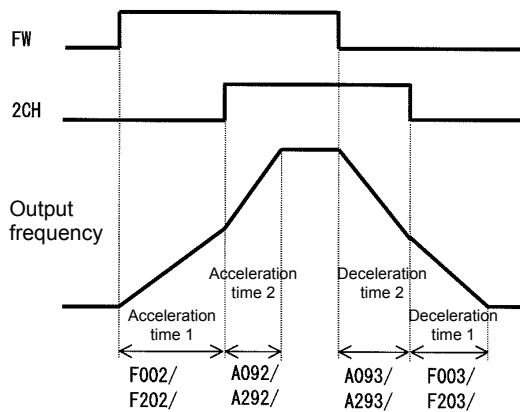

(Example 2) When "01" is specified for "A094" or "A294"

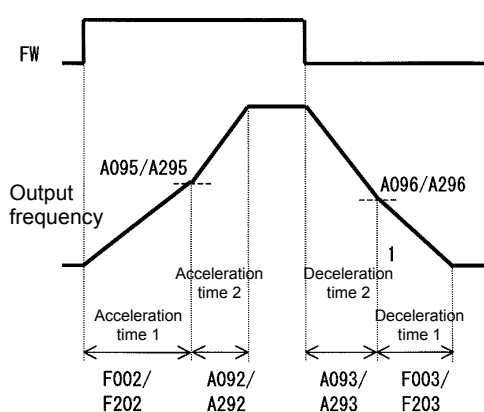

(Example 3) When "02" is specified for "A094" or "A294"

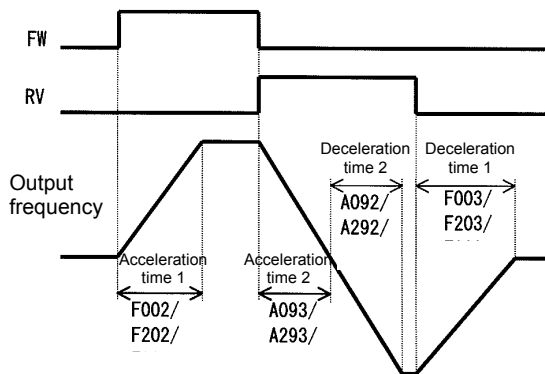

Chapter 7 Explanation of Functions

7.5.13 Acceleration/deceleration curve selection

You can set different patterns of motor acceleration and deceleration according to the type of system to be driven by the inverter.

Use functions "A097" and "A098" to select acceleration and deceleration patterns, respectively.

You can individually set an acceleration pattern for acceleration and a deceleration pattern for deceleration.

When the acceleration/deceleration pattern is set other than 00 (linear) using analog input as frequency source is to be avoided because it prolongs the acceleration or deceleration time.

Item	Function code	Data or range of data	Description
Acceleration/deceleration curve selection	A097/A098	00	Linear acceleration/deceleration
		01	S-curve acceleration/deceleration
		02	U-curve acceleration/deceleration
		03	Inverted-U-curve acceleration/deceleration
Acceleration/deceleration curve constants setting	A131/ A132	01 to 10	01 (small degree of swelling) ◇ 10 (large degree of swelling)

(1) Acceleration/deceleration pattern selection

Select acceleration and deceleration patterns with reference to the following table:

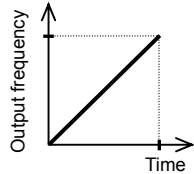
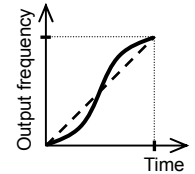
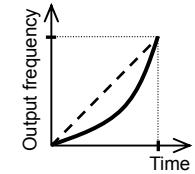
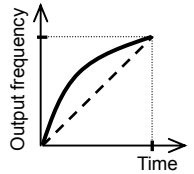
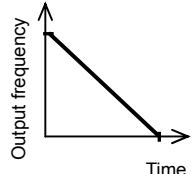
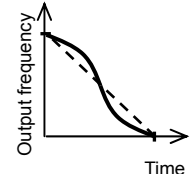
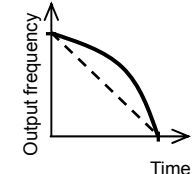
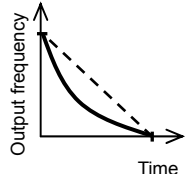
Setting	00	01	02	03
Curve	Linear	S curve	U curve	Inverted-U curve
A097 (acceleration pattern)				
A098 (deceleration pattern)				
Description	With this pattern, the motor is accelerated or decelerated linearly until its speed reaches the set output frequency.	This pattern is effective for preventing the collapse of cargo carried by a lift or conveyor driven by the inverter.	This pattern is effective for the tension control on a winding machine driven by the inverter (to prevent cutting of the object to be wound).	

(2) Curve constant (swelling degree)

Specify the swelling degree of the acceleration curve with reference to the following graphs:

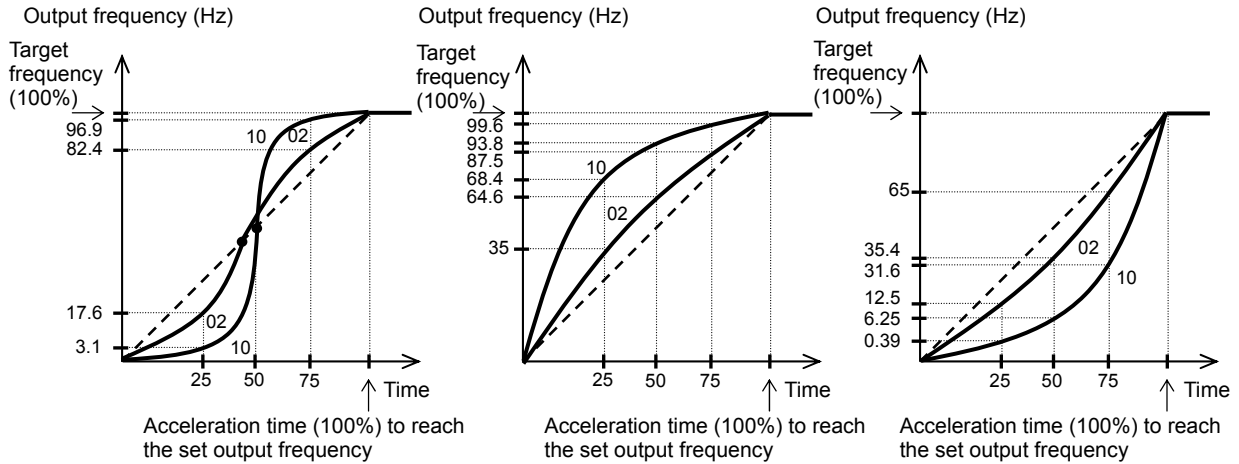

The acceleration or deceleration time may be shortened midway through the acceleration or deceleration according to the curve pattern.

7.5.14 Frequency operation function

The frequency operation function allows you to use the result of an arithmetic operation on two frequency commands as the actual frequency command or PID feedback data.

To use the operation result as the actual frequency command, specify "10" for the frequency source setting (A001).

To use the operation result as the PID feedback data, specify "10" for the PV source setting (A076).

Item	Function code	Data	Description
Operation-target frequency selection 1 and 2	A141/A142	00	Digital operator (A020/A220)
		01	Volume on the digital operator (Valid only when NES1-OP, OPE-SR/SRmini is connected)
		02	Input via the O/OI terminal
		04	Input via the Modbus communication
Operator selection for frequency operation	A143	00	Addition: (A141) + (A142)
		01	Subtraction: (A141) - (A142)
		02	Multiplication: (A141) x (A142)
Frequency source setting	A001	10	Output of operation result
PV source setting	A076	10	Output of operation result

Note 1: The [1] (up) and [2] (down) keys of the digital operator are ineffective when the frequency operation function is enabled. Also, the frequency displayed by the output frequency monitoring (d001), Scaled output frequency monitoring (d007), or output frequency setting (F001) cannot be changed with key operations.

Note 2: The settings of "A141" and "A142" can be the same.

Chapter 7 Explanation of Functions

7.5.15 Frequency addition function

The frequency addition function allows you to add or subtract the value specified as the frequency to be added (A145) to or from the frequency value of a selected frequency command. To use this function, assign function "50" (ADD) to an intelligent input terminal. When the ADD terminal is turned on, the inverter performs the addition or subtraction of the value specified as "A145".

Item	Function code	Data or range of data	Description
Frequency to be added	A145	0.00 to 400.00(Hz)	Setting of the frequency to be added
ADD direction select	A146	00	(Frequency command) + (A145)
		01	(Frequency command) - (A145)
Terminal function	C001 to C005	50	ADD selection of the trigger for adding the frequency (A145)

Note 1: If the sign of the frequency value in the frequency command changes from minus (-) to plus (+), or vice versa, as the result of frequency addition, the motor operation direction will be inverted.

Note 2: When the PID function is used, the frequency addition function can apply to PID target data. (In such cases, the data display by function "A145" is in percentage [in steps of 0.01%]).

7.5.16 Remote control function (UP and DWN)

The remote control function allows you to change the inverter output frequency by operating the UP and DWN terminals (intelligent input terminals).

To use this function, assign functions "27" (UP) and "28" (DWN) to two of the terminal [1] to [5] functions (C001 to C005).

- This function is only effective for multispeed operation when "01 (terminal)" or "02 (oprater)" has been specified for the frequency source setting (A001). If "01" (control circuit terminal block) has been specified, this function is only effective when the analog command holding function (AHD) is enabled.

This function is ineffective when the external analog input has been specified for the frequency source setting (A001). This function cannot be used to set frequencies for jogging operation.

When the UP or DWN terminal is on, the 1st and 2nd acceleration/deceleration time follows the settings of "F002/F202"/"F003/F203". To switch between the 1st and 2nd controls, assign function "08" (SET) to intelligent input terminals, and turn on and off the SET terminal for switching.

You can store the frequency settings adjusted using the remote control function (UP and DWN signals). Set 01 (enable) on C101 to store the frequency settings.

In case of the C101=00, the set frequency returns to a value at the time of the power supply injection when inverter is the under voltage state.

You can also clear the stored frequency settings. Assign function "29" (UDC) to an intelligent input terminal, and turn on or off the UDC terminal to clear or store, respectively, the frequency settings adjusted with the UP and DWN signals. In this case, the value obeys setting of C104.

Item	Function code	Data	Description
Terminal function	C001 to C005	27	UP: Remote control UP function
		28	DWN: Remote control DOWN function
		29	DWN: Remote control data clearing
Up/Down memory mode selection	C101	00	Disabling the storage of frequency settings
		01	Enabling the storage of frequency settings (*1)
Up/Down clear terminal input mode selection	C104	00	0Hz
		01	Flash data when power supply is turn on

*1 Do not operate the UP or DWN terminal after the inverter power is shut off. Otherwise, the frequency settings may not be stored correctly.

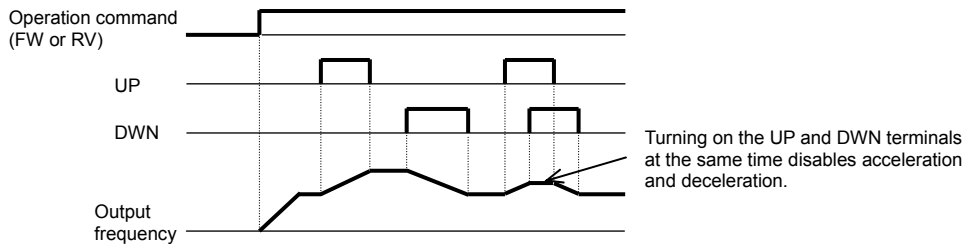

7.5.17 V/f gain setting [A045/A245]

The V/f gain setting function allows you to change the inverter output voltage by specifying the rate of the output voltage to the voltage (100%) selected with the AVR voltage select function (A082).

If the motor operation is cranky, try to decrease the gain setting.

Item	Function code	Range of data	Description
V/f gain setting	A045/A245	20. to 100. (%)	Setting of the rate of reducing the output voltage

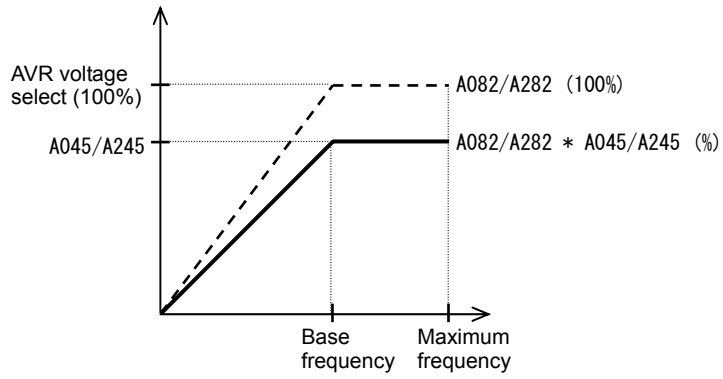

Chapter 7 Explanation of Functions

7.5.18 PID function

The PID function allows you to use the inverter for the process control on fluid flow, airflow, and pressure. To enable this function, specify "01 enabled" or "02 inverted data output enabled" for function "A071". You can disable the PID function with an external signal during the PID operation. For this purpose, assign function "23" (PID terminal: disabling PID operation) to an intelligent input terminal. Turning the PID terminal on disables the PID function and makes the inverter perform the normal output. With the PID function, you can limit the PID output according to various conditions. maximum frequency, frequency limiter, PID variation range (A078).

Item	Function code	Data or range of data	Description
PID Function Enable	A071	00	Disabling the PID operation
		01	Enabling the PID operation
		02	Enabling inverted-data output
PID proportional gain	A072	0.2 to 25.0	Proportional gain
PID integral time constant	A073	0.0 to 3600.(s)	Integrated gain
PID derivative gain	A074	0.00 to 100.0(s)	Derivative gain
PV scale conversion	A075	0.01 to 99.99	Scale for unit conversion of PID feedback data
PV source setting	A076	01	O/OI-L: [0 to 10 V]/[4-20mA]
		02	Modbus communication
		10	Operation result (*1)
Reverse PID action	A077	00	Disabling the inverted output
		01	Enabling the inverted output (deviation polarity inverted)
PID variation range	A078	0.0 to 100.0(%)	Range of PID data variation with reference to the target value
PID sleep function action threshold	A156	0.0 to 400.0(Hz)	When PID output drops below the operating level, to stop the behavior.
PID sleep function action delay time	A157	0.0 to 25.5(s)	Delay to the start of the operation of sleep
PID sleep function return threshold	A158	A156 to 400.00Hz	Level of return sleep behavior
PID deviation level setting	C044	0.0 to 100.0(%)	Level to determine the OD signal output
Off level of feedback comparison signal	C052	0.0 to 100.0(%)	Level to determine the FBV signal output
Onlevel of feedback comparison signal	C053	0.0 to 100.0(%)	Level to determine the FBV signal output

(1) Basic configuration of PID control

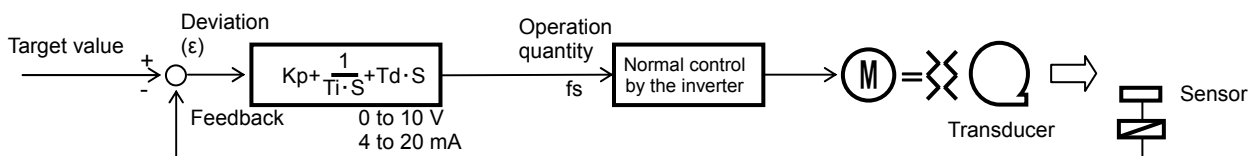

Kp: Proportional gain Ti: Integral time Td: Derivative time s: Operator ε : Deviation

(2) PID operation

1) P operation

The proportional (P) operation stands for the operation in which the change in operation quantity is in proportion to the change in target value.

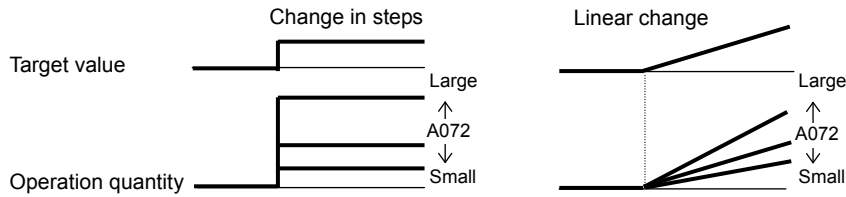

2) I operation

The integral (I) operation stands for the operation in which the operation quantity increases linearly over time.

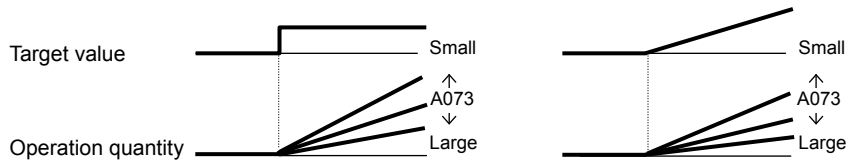

3) D operation

The derivative (D) operation stands for the operation in which the operation quantity changes in proportion to the rate of change in the target value.

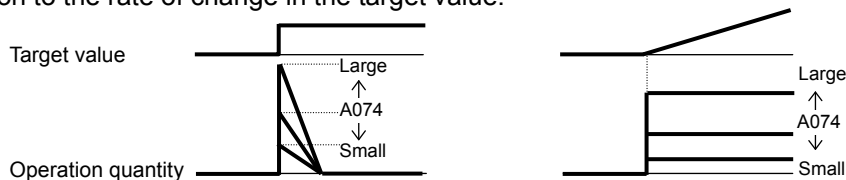

The PI operation is a combination of the P operation 1) and I operation 2). The PD operation is a combination of the P operation 1) and D operation 3). The PDI operation is a combination of the P operation 1), I operation 2), and D operation 3).

(3) PID scale

About (A075) is as the following equation.

$$(\text{The converted value}) = (\text{Value before conversion}) \times (\text{A075})$$

d004	F001	A011	A012	A020	A220	A021	A022
A023	A024	A025	A026	A027			

(4) PV source setting

Select the PV source to be used for the feedback signal with the PV source setting function (A076).

The targeted value is set by A001.

When you specify the 02 (Modbus communication) for the PV source setting (A076), transfer data as described below.

Write the setting data (on the assumption that "10000" indicates 100%) to register address 0006h.

Register No.	Function name	Function code	Readable/writable (R/W)	Monitored data or setting	Data resolution
0006h	PID feedback	—	R/W	0 to 10000	0.01 [%]

Note: This register is readable and writable. However, this register can be read only when Modbus RTU has been specified as the communication mode for PID feedback. It cannot be read with other settings.

Chapter 7 Explanation of Functions

(5) Output of inverted PID deviation

Some sensor characteristics may cause the polarity of the deviation of feedback data from the target value to be inconsistent with the inverter operation command. If the inconsistency occurs, specify "01" for function "A077" to invert the polarity of the deviation.

Example: When controlling the compressor for a refrigerator

Assume that the temperature and voltage specifications of the temperature sensor are -20°C to $+100^{\circ}\text{C}$ and 0 to 10 V and the target value is 0°C .

If the current temperature is 10°C and the inverter is under the normal type of PID control, the inverter will reduce the output frequency because the feedback data is larger than the target value.

→ In such a case, specify "01" for function "A077" to invert the feedback deviation. Then, the inverter will increase the output frequency.

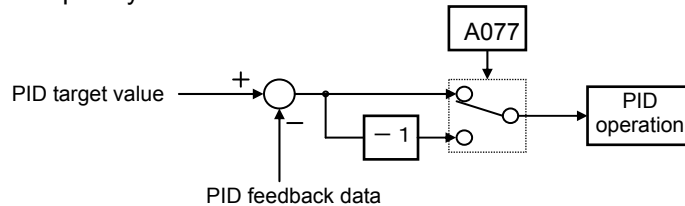

(6) Limitation on PID variation range

You can limit the PID output to within a specific range with reference to the target value.

To use the PID variation limit function, set the PID variation range (A078).

(Set a value on the assumption that the maximum frequency corresponds to 100%.)

The variation of PID output is limited within \pm "value of A078" from the target value.

(Setting "0.0" for the PID variation range [A078] disables the PID variation limit function.)

This function is deactivated when 0.0 is set on A078.

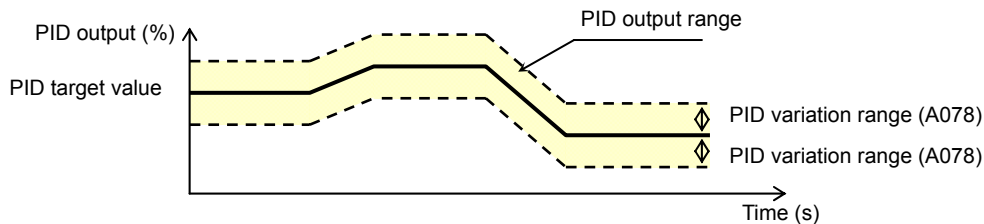

(7) Output of inverted PID deviation

If the inverter is under the normal PID control and the PID operation result is a negative value, the frequency command to the inverter will be limited to 0 Hz. However, when "02" (enabling the inverted output) is set for the PID Function Enable (A071), the PID operation result to be output to the inverter is inverted if the result is a negative value.

Setting "02" for function "A071" disables the PID variation limit (A078) described above.

(8) PID gain adjustment

If the inverter response is unsteady when the PID control function is used, try to adjust gain settings as follows:

- If the feedback data does not quickly follow the change in the target value → Increase the P gain (A072).
- If the feedback data is unstable although it quickly follows the change in the target value → Reduce the P gain (A072).
- If considerable time is required until the feedback data matches the target value → Reduce the I gain (A073).
- If the feedback data fluctuates unsteadily → Increase the I gain (A073).
- If the inverter response is slow even after the P gain is increased → Increase the D gain (A074).
- If the feedback data becomes fluctuant and unsteady when the P gain is increased → Reduce the D gain (A074).

(9) Maximum PID deviation output (OD)

You can set the PID deviation level (C044) for PID control. When the PID deviation (ϵ) exceeds the level set as the level "C044", the signal is output to an intelligent output terminal.

A value from 0 to 100 can be set as the level "C044". The range of values corresponds to the range of target values from 0 to the maximum.

To use this output function, assign function "04" (OD) to one of the terminal functions C021 or the alarm relay terminal function C026.

(10) Feedback comparison signal

A feedback comparison signal can be output to an intelligent output terminal when the PID feedback data exceeds the specified range.

To use this signal output function, assign function "31" (FBV) to one of the terminal functions C021 or the alarm relay terminal function C026.

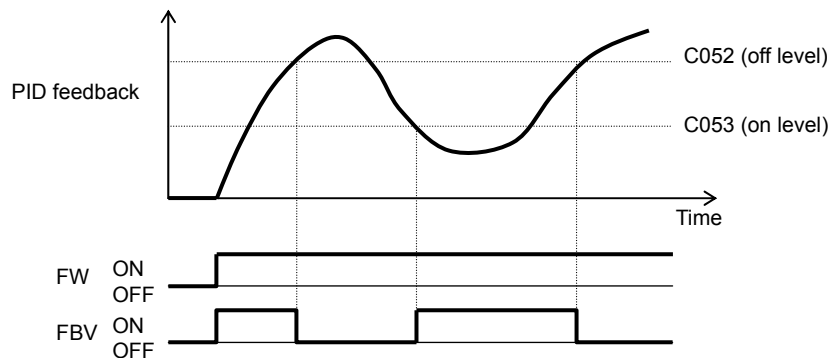

(11) Process variable (PV), PID feedback monitoring (d004)

You can monitor the PID feedback data on the inverter.

When you set a PV scale conversion with function "A075", the value to be displayed as the monitored data can be the product of the feedback data and the scale.

"Monitored value" = "feedback data (%)" x "PV scale conversion (A075)"

(12) Reset of PID integration (PIDC)

This reset function clears the integral result of PID operation.

To use this function, assign function "24" (PIDC) to one of the terminal functions C001 to C005.

The integral result is cleared each time the PIDC terminal is turned on.

Never turn on the PIDC terminal during the PID operation. Otherwise, the inverter may trip because of overcurrent. Be sure to disable the PID function before turning on the PIDC terminal.

Chapter 7 Explanation of Functions

(13)PID sleep function

If PID command is below the (A156), it stop the output after the (A157). If PID command is above the (A156), it start the output after the (A157). If it returns within (A157), PID sleep function doesn't work. (A158) should set higher than (A156).

Even if the PID function is disabled, when the frequency command value is below the (A156), it stop the output after (A157). When the frequency command value is above (A158), it start the output after (A157). When using this function, please do not use the terminal free-run(FRS).

7.5.19 Energy-saver operation [A085/A086]

The energy-saver operation function allows you to automatically minimize the inverter output power while the inverter is driving the motor at constant speed. This function is suited to operating a fan, pump, or other load that has a reduced-torque characteristic.

To use this function, specify "01" for the operation mode selection (A085).

Use the energy saving mode tuning function (A086) to adjust the response and accuracy of the energy-saver operation.

The energy-saver operation function controls the inverter operation comparatively slowly. Therefore, if a sudden change in the load occurs (e.g., impact load is applied), the motor may stall, and, consequently, the inverter may trip because of overcurrent.

Item	Function code	Data	Description
Operation mode selection	A085	00	Normal operation
		01	Energy-saving operation

Item	Function code	Data	Response	Accuracy
Energy saving mode tuning	A086	0	Slow	High
		↕	↕	↕
		100	Quick	Low

7.5.20 Stabilization constant setting

The stabilization constant setting function allows you to adjust the inverter to stabilize the motor operation when the motor operation is unstable.

If the motor operation is unstable, check the motor capacity setting (H003/H203) and motor pole setting (H004/H204) to determine whether the settings match the motor specifications. If they do not match, readjust the settings. If the primary resistance of the motor is less than the standard motor specification, try to increase the setting of "H006/H206 " step by step. Try to reduce the setting of "H006/H206 " if the inverter is driving a motor of which the capacity is higher than the inverter rating.

You can also use the following methods to stabilize the motor operation:

- 1) Reducing the carrier frequency (b083)
- 2) Reducing the V/f gain setting (A045)

Item	Function code	Data	Description
Stabilization constant	H006/H206	0. to 255.	Increase or reduce the setting to stabilize the motor.
V/f gain setting	A045/A245	20. to 100. (%)	Reduce the setting to stabilize the motor.
Carrier frequency setting	b083	2.0 to 15.0 (kHz)	Reduce the setting to stabilize the motor.

Chapter 7 Explanation of Functions

7.5.21 2nd motor control function (SET)

This motor control function allows you to switch the inverter settings to control two different types of motors. To use this function, assign function "08" (SET) to the terminal [1] to [5] functions (C001 to C005). Turn the SET terminal on and off for switching. (OFF:1st motor , ON:2nd motor)

Item	Function code	Data	Description
Terminal function	C001 to C005	08	SET: Set 2nd motor data

You can switch the following functional settings with the SET terminal:

F002/F202:	Acceleration (1) time setting
F003/F203:	Deceleration (1) time setting
A001/A201:	Frequency source selection
A002/A202:	Run command source selection
A003/A203:	Base frequency setting
A004/A204:	Maximum frequency setting
A020/A220:	Multispeed frequency setting
A041/A241:	Torque boost method selection
A042/A242:	Manual torque boost value
A043/A243:	Manual torque boost frequency adjustment
A044/A244:	V/F characteristic curve selection
A045/A245:	V/f gain setting
A046/A246:	Voltage compensation gain setting for automatic torque
A047/A247:	Slippage compensation gain setting for automatic torque
A061/A261:	Frequency upper limit setting
A062/A262:	Frequency lower limit setting
A081/A281:	AVR function selection
A082/A282:	AVR voltage selection
A092/A292:	Acceleration (2) time setting
A093/A293:	Deceleration (2) time setting
A094/A294:	Select method to switch to Acc2/Dec2 profile
A095/A295:	Acc1 to Acc2 frequency transition point
A096/A296:	Dec1 to Dec2 frequency transition point
b012/b212:	Electronic thermal setting (calculated within the inverter from current output)
b013/b213:	Electronic thermal characteristic
b021/b221:	Overload restriction operation mode selection
b022/b222:	Overload restriction level setting
b023/b223:	Deceleration rate at overload restriction
C041/C241:	Overload warning level setting
H003/H203:	Motor capacity
H004/H204:	Motor poles setting
H006/H206:	Motor stabilization constant

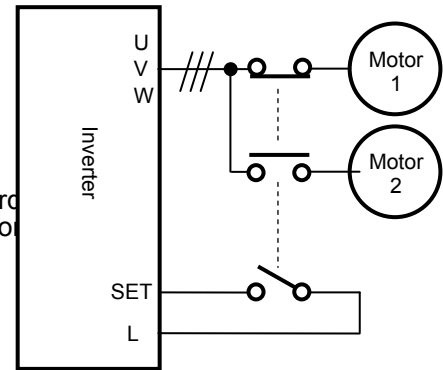

Since the inverter indicates no distinction among the 1st and 2nd controls, confirm the kind of control settings with the on/off states of the SET terminal.

Please perform the change during an inverter & motor stop.

This function is effective during an inverter stop.

7.5.22 DC braking (DB) setting

The DC braking function allows you to apply DC braking to the motor according to the load on the motor. You can control DC braking in two ways: the external control through signal input to intelligent input terminals and the internal control to be performed automatically when the motor is started and stopped. Note that the motor cannot be stopped by DC braking if the load on the motor produces a large moment of inertia.

Item	Function code	Data or range of data	Description
DC braking enable	A051	00	Internal DC braking is disabled.
		01	Internal DC braking is enabled.
		02	Internal DC braking is enabled. (The braking operates only with the set braking frequency.)
DC braking frequency setting	A052	0.00 to 60.00 (Hz)	With internal DC braking enabled, DC braking is started when the output frequency reaches the set braking frequency.
DC braking wait time	A053	0.0 to 5.0 (s)	The DC braking wait time specifies the delay in starting DC braking after the set braking time has elapsed or the DB terminal has been turned on.
DC braking force during deceleration/ DC braking force for starting	A054/A057	0. to 100. (%)	"0" specifies the smallest force (zero current); "100" specifies the largest force (rated current).
DC braking time for deceleration	A055	0.0 to 10.0 (s)	This setting is valid for the external DC braking in edge mode or for the internal DC braking.
DC braking/edge or level detection for [DB] input	A056	00	Edge mode (See examples 1-a to 6-a.)
		01	Level mode (See examples 1-b to 6-b.)
DC braking time for starting	A058	0.0 to 10.0 (s)	This setting is valid for the internal DC braking. DC braking is started when the motor-start command is input.
DC braking carrier frequency setting	A059	2 to 15(kHz)	

(1) Carrier frequency for DC braking

Use the DC braking carrier frequency setting (A059) to specify the carrier frequency for DC braking. But the braking power reduced is reduced when 5kHz are set as shown below. For detailed decreasing ratio, "DC braking force limiter" is to be referred.

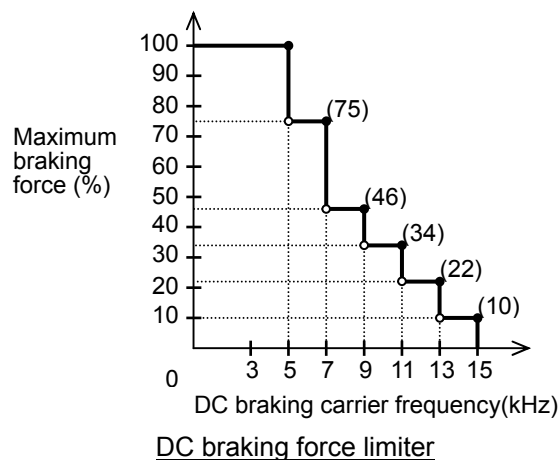

Chapter 7 Explanation of Functions

(2) External DC braking

Assign function "07" (DB) to terminal function (C001 to C005).

Direct braking control by ON/OFF of DB terminal when the setting of DC braking enable (A051) is 00(Invalid) and 01(Valid).

Adjust the braking force by adjusting the DC braking force setting (A054).

When you set the DC braking wait time (A053), the inverter output will be shut off for the set period of delay, and the motor will run freely during the period. DC braking will be restarted after the delay.

When setting the DC braking time with function "A055" or for the DC braking operation via the DB terminal, determine the length of time in consideration of the heat generation on the motor.

Select the braking mode by the DC braking/edge or level detection for [DB] input (A056), and then make any other necessary settings suitable for your system.

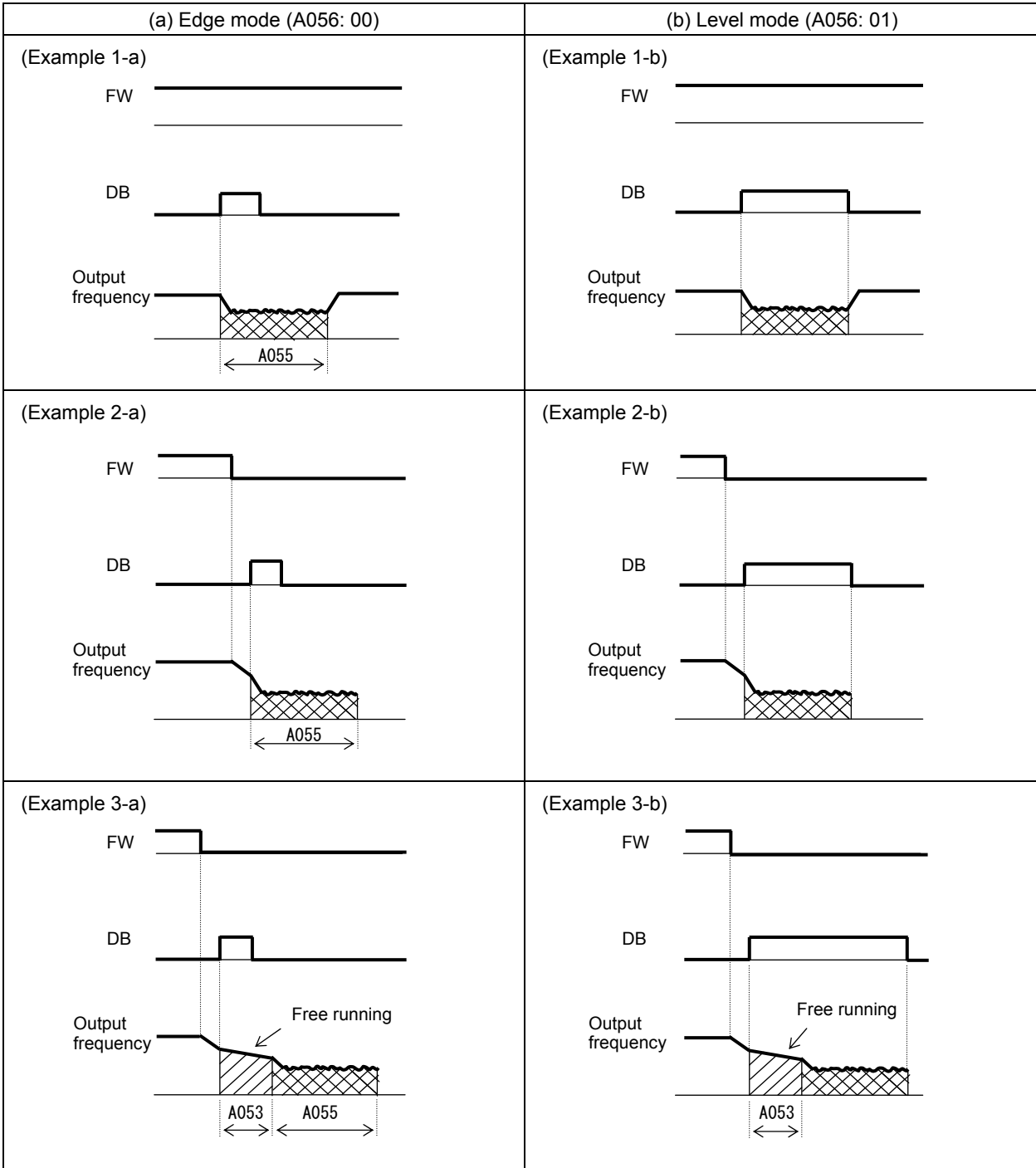

(3) Internal DC braking (A051: 01)

You can apply DC braking to the motor even without entering braking signals via the DB terminal when the inverter starts and stops. To use the internal DC braking function, specify "01" for the DC braking enable (A051).

Use function "A057" to set the DC braking force for starting, and use function "A058" to specify the DC braking time for starting, regardless of the braking mode selection (edge or level mode). (See examples 4-a and 4-b.)

Set the braking force for periods other than starting by using the DC braking force setting (A054).

Set the output frequency at which to start DC braking by using the DC braking frequency setting (A052).

When you set the DC braking wait time (A053), the inverter output will be shut off when the output frequency reaches the setting of "A052" after the operation command (FW signal) is turned off, and the motor will run freely for the delay time set by "A053". DC braking will be started after the delay (A053).

The internal DC braking operation to be performed when the operation command is switched from the stop command to the start command varies depending on the braking mode (edge or level mode).

Edge mode: The DC braking time setting (A055) is given priority over operation commands, and the inverter performs DC braking according to the setting of "A055". When the output frequency reaches the setting of "A052" the inverter performs DC braking for the time set for "A055". Even if the stop command is input during DC braking, DC braking continues until the time set for "A055" elapses. (See examples 5-a and 6-a.)

Level mode: Operation commands are given priority over the DC braking time setting. The inverter follows operation commands, regardless of the DC braking time setting (A055). If the start command is input during DC braking, the inverter starts the normal motor operation, regardless of the DC braking time setting (A055). (See examples 5-b and 6-b.)

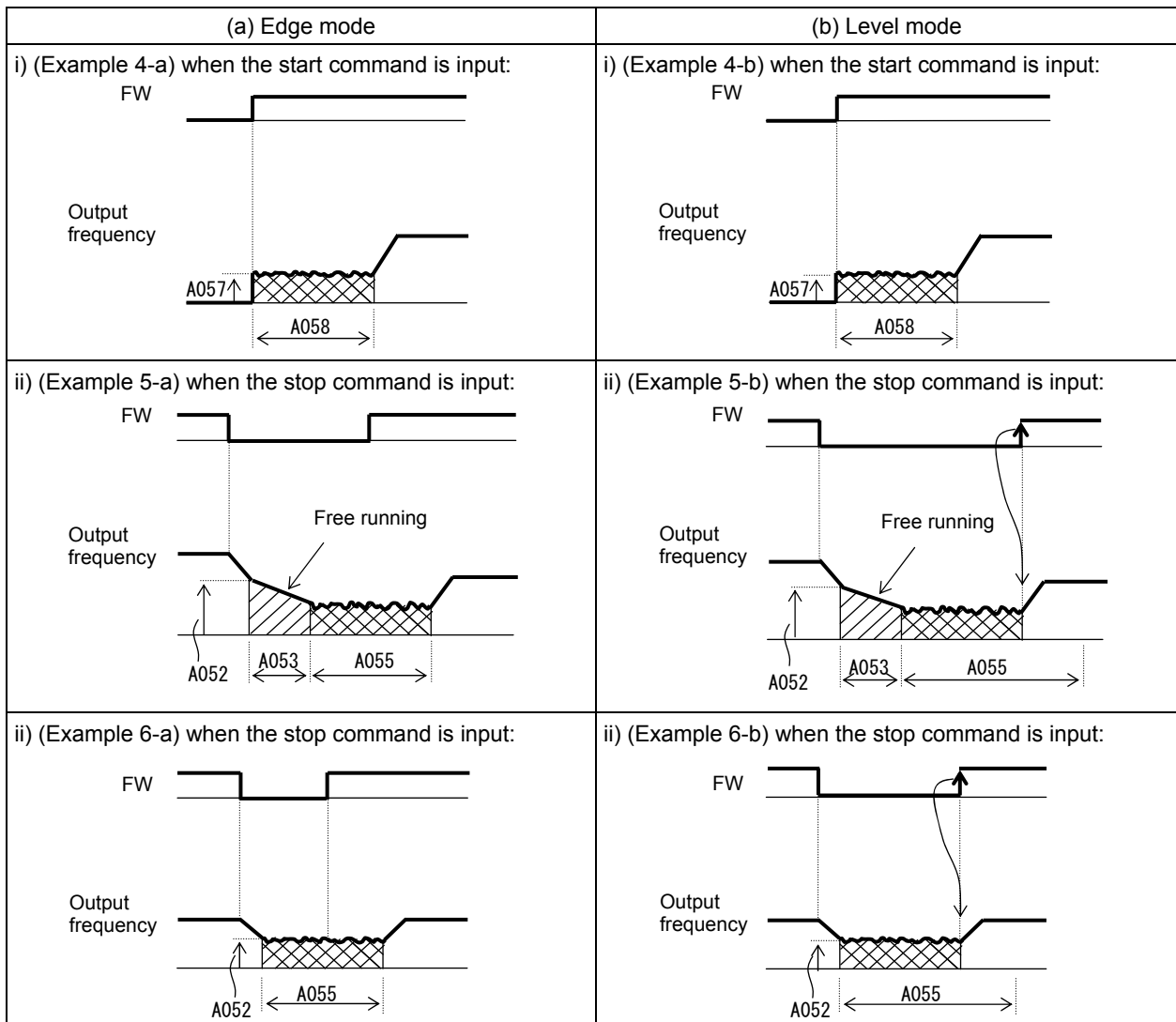

Chapter 7 Explanation of Functions

(4) Internal DC braking (triggered only when the output frequency reaches a set frequency) (A051: 02)
 You can also operate the internal DC braking function so that DC braking is applied to the motor when the inverter output frequency falls to the DC braking frequency setting (A052) or below.

Please do not use external DC braking by ON/OFF of DB terminal when you select this function.
 In this mode, DC braking operates only when the operation command signal is on (i.e., the start command is input).

The inverter starts DC braking when both the frequency set by the frequency command and the current output frequency fall to the DC braking frequency setting (A052) or below. (See example 7-a.)

When the frequency set by the frequency command increases to the "setting of 'A052' + 2 Hz" or more, the inverter stops DC braking and restores its normal output. (See example 7-a.)

If the frequency set by the frequency command is 0 Hz when the start command is input via an analog input terminal, the inverter will start operation with DC braking because both the frequency set by the frequency command and current output frequency are 0 Hz. (See example 7-b.)

If the operation command signal (start command) is turned on when the frequency command specifies a frequency larger than the DC braking frequency (A052), the inverter will start operation with the normal output.

(Example 7-a)

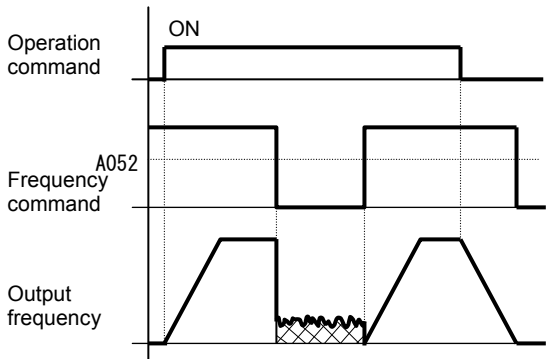

(Example 7-b)

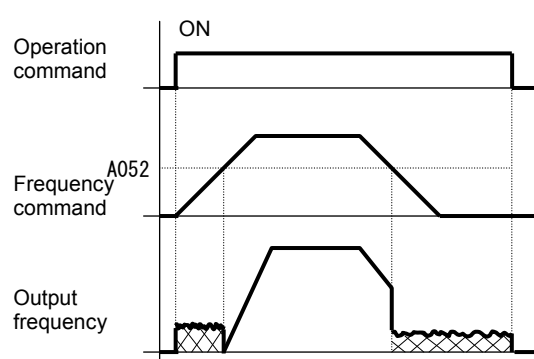

How the inverter returns to the normal output varies depending on the setting of the DC braking/edge or level detection for [DB] input (A054).

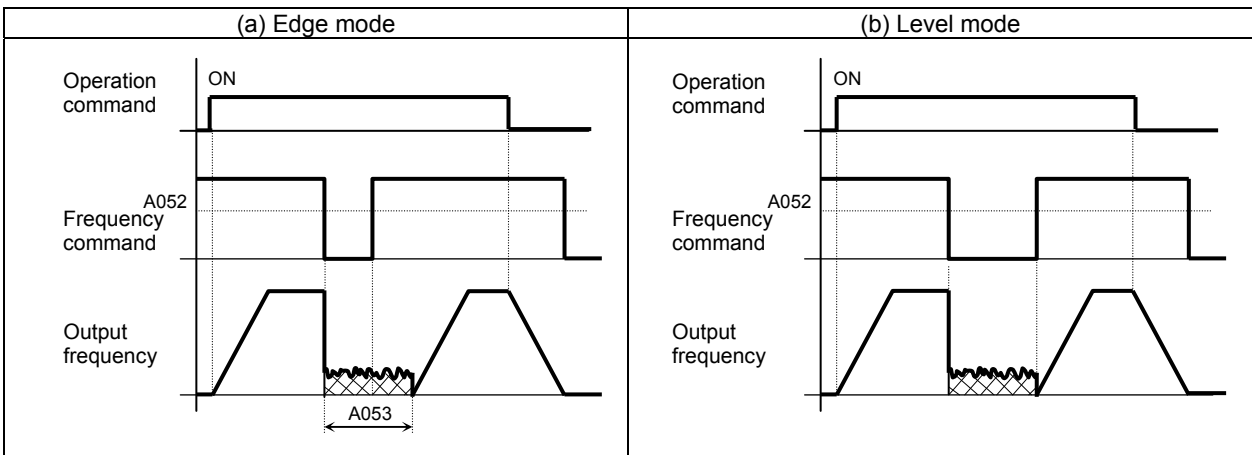

7.6 Functions related to the operator display

7.6.1 STOP key enable [b087]

When the control circuit terminal block is selected as the device to input operation commands, the STOP key enable function allows you to enable or disable the motor-stopping and trip reset functions of the STOP key of the digital operator.

This function is effective only when the digital operator (02) is not specified for the run command source setting (A002).

If the digital operator (02) is specified for "A002", the motor-stopping and trip reset functions of the STOP key are enabled regardless of this setting (STOP key enable).

Function code	Data	Stop command with STOP key	Trip reset command with STOP key
b087	00	Enabled	Enabled
	01	Disabled	Disabled
	02	Disabled	Enabled

7.6.2 Software lock (SFT) function [b031]

The software lock function allows you to specify whether to disable rewriting of the data set for functional items. Use this function to protect the data against accidental rewriting.

You can select the functional items to be locked and the method of locking as described below.

When using an intelligent input terminal for this function, assign function "15" (SFT) to one of the terminal [1] to [5] functions (C001 to C005).

It is the mode for allowing changes during operation when b031 is set "10", high level access.

Function code	Data	SFT terminal	Description
b031	00	ON/OFF	Disabling rewriting of items other than "b031" (when SFT is on) or enabling rewriting (when SFT is off)
	01	ON/OFF	Disabling the rewriting of items other than "b031", "F001", "A020", "A220", "A021" to "A027", and "A038" (when SFT is on) or enabling rewriting (when SFT is off)
	02	—	Disabling the rewriting of items other than "b031"
	03	—	Disabling the rewriting of items other than "b031", "F001", "A020", "A220", "A021" to "A027", and "A038"
	10	—	The mode allowing changes during operation.((Run Mode Edit) (See Chapter 13))

The following function can prohibit Read/Copy by WOP.

function	code	Data	Description
Data Read/Write select	b166	00	Read/Write OK
		01	Read/Write Protected

7.6.3 Forcible-operation from digital operator (OPE) function

The forcible-operation function allows you to forcibly enable the inverter operation from the digital operator when the digital operator is not selected as the device to input frequency and operation commands. An intelligent input terminal is used to turn this function on and off.

When the intelligent input terminal to which the forcible-operation function is assigned is off, frequency and operation commands are input from the devices selected by functions "A001" and "A002". When the terminal is on, the device to input frequency and operation commands is forcibly switched to the digital operator.

If the input device is switched while the inverter is operating, the current operation command is canceled and the inverter stops the output. When restarting the inverter operation, turn off the operation command that was to be entered from each input device for safety's sake, and then enter a new operation command. When use it together with (F-TM) function, this function(OPE) is given priority.

Item	Function code	Data	Description
Terminal function	C001 to C005	31	OPE: Forcible operation

Chapter 7 Explanation of Functions

7.6.4 Forcible-operation from terminal (F-TM) function

The forcible-operation function allows you to forcibly enable the inverter operation via control circuit terminals when the control circuit terminal block is not selected as the device to input frequency and operation commands. An intelligent input terminal is used to turn this function on and off.

When the intelligent input terminal to which the forcible-terminal operation function is assigned is off, frequency and operation commands are input from the devices selected by functions "A001" and "A002". When the terminal is on, the device to input frequency and operation commands is forcibly switched to the control circuit terminal block.

If the input device is switched while the inverter is operating, the current operation command is canceled and the inverter stops the output. When restarting the inverter operation, turn off the operation command that was to be entered from each input device for safety's sake, and then enter a new operation command. When use it together with (OPE) function, (OPE) function is given priority.

Item	Function code	Data	Description
Terminal function	C001 to C005	51	F-TM: Forcible-terminal operation

7.6.5 Action selection in case of external operator disconnection [b165]

When the inverter detects a disconnection with the operator(Operator communication is cut off for five seconds or more.), inverter operation is subject to (b165).

Item	Function code	Data	Description
Ex. operator com. loss action	b165	00	Trip (E40.x)
		01	Trip after Deceleration stop (E40.x)
		02	Disregard
		03	Free-run stop
		04	Deceleration stop

7.6.6 Initial-screen selection (selection of the initial screen to be displayed after power-on)

The initial-screen selection function allows you to specify the screen that is displayed on the digital operator immediately after the inverter power is turned on. The table below lists the screens (items) selectable. (The factory setting is "01" [d001].)

Item	Function code	Data	Description
Initial-screen selection	b038	000	Func. code that SET key pressed last displayed. (*1)
		001 to 060	d001 to d060 (set value(***) is the monitor No. (d***))
		201	F001 (output frequency setting)
		202	B display of LCD operator (In case of Digital operator, same (000) setting)

(*1):(Example) If the inverter power is turned off immediately after the setting of "b038" has been changed, the monitor will display "b038" as the initial screen after the next power-on.

7.6.7 Select automatic return to the initial display [b164]

If you do not manipulate the operator for 10 minutes, the operator screen automatically changes to the screen that you set in the (b038).

This function is enabled by setting the b164 = 01.

Item	Function code	Data	Description
Automatic return to the initial display	b164	00	Disable
		01	Enable

7.6.8 NES1-OP display selection [b150]

NES1-OP key does not work when you connect an digital operator or remote operator.

This function sets the monitor code to be displayed in NES1-OP.

Item	Function code	Data	Description
NES1-OP display selection	b150	001 to 050	d001 to d050 corresponding to the monitor item

7.6.9 Data Read/Write selection [b166]

This function is to choose whether to allow read / write of data in the WOP.

Item	Function code	Data	Description
Data Read/Write selection	b166	00	Enable
		01	Disable

See section 7.6.2

7.6.10 Display limitation function (DISP)

To use this function, assign function "86" (DISP) to one of the terminal [1] to [5] functions (C001 to C005). While the (DISP) input is ON , the operator displays a parameter chosen by initial-screen selection. And cannot select other parameter.

Item	Function code	Data	Description
Terminal [1] to [5] functions	C001 to C005	86	DISP: Display limitation function

Chapter 7 Explanation of Functions

7.6.11 Function code display restriction [b037]

The function code display restriction function allows you to arbitrarily switch the display mode or the display content on the digital operator.

Item	Function code	Data	Description
Function code display restriction	b037	00	Full display
		01	Function-specific display
		03	Data comparison display
		04	Basic display
		05	Monitor mode (d***) only

(1) Function-specific display mode

If a specific function has not been selected, the monitor does not display the parameters concerning the specific function.

The following table lists the details of display conditions:

No.	Display condition	Parameter displayed when the display condition is met
1	One of C001 to C005 = 08	F202, F203, A201 to A204, A220, A241 to A247, A261, A262, A281, A282, A292 to A296, b212, b213, b221 to b223, C241, H203, H204 and H206
2	A044 = 02 or/ One of C001 to C005 = 08 and A244 = 02	b100 to b113
3	b013 = 02 or/ One of C001 to C005 = 08 and b213 = 02	b015 to b020
4	A044 = 00 or 01	A041 to A043, A046, A047
5	One of C001 to C008 = 08 and A244 = 00, 01	A241 to A243, A246, A247
6	A051 = 01, 02 or/ One of C001 to C005 = 06, 07	A052 to A059
7	A071 = 01, 02	d004, A072 to A079, A156 to A158, C044, C052, C053
8	A097, A098 = 01 to 03	A131, A132
9	b050 = 01 to 03	b051 to b054, b134, b135
10	b130 = 01 to 03	b131 to b134
11	C070 = 01	C071 to C078

(2) Data comparison display mode

The monitor displays only the parameters that have been changed from the factory settings, except all monitoring indications (d***) and code "F001".

(3) Basic display mode

The monitor displays basic parameters.

The following table lists the parameters that can be displayed in basic display mode:

No.	Code displayed	Item
1	d001 to d104	Monitoring indication
2	F001	Output frequency setting
3	F002	Acceleration (1) time setting
4	F003	Deceleration (1) time setting
5	F004	Keypad Run key routing
6	A001	Frequency source setting
7	A002	Run command source setting
8	A003	Base frequency setting
9	A004	Maximum frequency setting
10	A020	Multispeed frequency setting
11	A021	Multispeed 1 setting
12	A022	Multispeed 2 setting
13	A023	Multispeed 3 setting
14	A044	V/F characteristic curve selection, 1st motor
15	A045	V/f gain setting
16	A085	Operation mode selection
17	b001	Selection of restart mode
18	b002	Allowable under-voltage power failure time
19	b008	Selection of retry after trip
20	b011	Retry wait time after trip
21	b031	Softlock mode selection
22	b037	Function code display restriction
23	b083	Carrier frequency setting
24	b084	Initialization mode (parameters or trip history)
25	b130	Overvoltage suppression enable
26	b131	Overvoltage suppression level
27	b180	Initialization trigger
28	C001	Input terminal [1] function
29	C002	Input terminal [2] function
30	C003	Input terminal [3] function
31	C004	Input terminal [4] function
32	C005	Input terminal [5] function
33	C021	Output terminal [11] function
34	C036	Alarm relay active state

(4) Monitor mode (d***) Only.

The monitor displays only the parameters of the monitor mode(d***) and b037.

7.6.12 Button sensitivity selection [C151]

This function sets Button sensitivity. If set to No, the operation button is disabled.

Item	Function code	Data	Description
Button sensitivity selection	C151	0 to 250	Data times 2ms
		no	Disable button

Chapter 7 Explanation of Functions

7.6.13 Scroll sensitivity selection [C152]

When the display data of the operator, press and hold the UP or DOWN key. Then, the data update rate is faster. Update rate can be adjusted by (C152).

Item	Function code	Data	Description
Operating speed scroll	C152	1 to 20	1: (Faster) 20: (Slower)

This function only works when connected to an operator.

7.7 Functions about restarting

7.7.1 Retry (Under Voltage , Over Current / Over Voltage)

(1) Retry (restart) after under voltage / Over Current / Over Voltage

You can select tripping or retrying (restarting) the motor operation as the inverter operation to be performed at the occurrence of undervoltage.

If you specify a retry operation for the selection of restart mode (b001), the inverter will retry the motor operation for the number of times set as "b005" after a under Voltage, and then trip if all retries fail. (The inverter will not trip if you specify an unlimited number of retries.)

With function "b004" you can select whether to make the inverter trip when a undervoltage occur while the inverter is in a stopped state.

When selecting a retry operation, also set the retry conditions listed below according to the system to be driven by the inverter.

Even during a retry operation, the inverter will trip with error code "E09" (undervoltage) displayed if the undervoltage status continues for 40 seconds.

Item	Function code	Data or range of data	Description
Selection of restart mode for under voltage trip (*3) (*5)	b001	00	Tripping
		01	Restarting the motor with 0 Hz at retry
		02	Starting the motor with an active matching frequency at retry. (See example 1.) (*2)
		03	Starting the motor with an active matching frequency at retry. The inverter trips after decelerating and stopping the motor. (*1) (*2)
Allowable under-voltage power failure time	b002	0.3 to 25.0 (s)	Restarting the motor when the power failure duration does not exceed the specified time (See example 1.) Tripping when the power failure duration exceeds the specified time (See example 2.)
Retry wait time before motor restart for under voltage trip	b003	0.3 to 100. (s)	Time to wait until restarting the motor
the selection of a trip after undervoltage in the stopped state (*3)	b004	00	Disabling the inverter from tripping
		01	Enabling the inverter to trip
		02	Disabling the inverter from tripping when the inverter is stopped or while the motor is being decelerated or stopped after the operation command has been turned off
Number of restarts on under-voltage trip events	b005	00	Retrying the motor operation up to 16 times after instantaneous power failure
		01	Retrying the motor operation an unlimited number of times after instantaneous power failure
Restart frequency threshold	b007	0.00 to 400.0 (Hz)	Restarting the motor with 0 Hz if the frequency becomes less than the frequency set here during motor free-running (See examples 3 and 4.)
Trip/retry selection for over voltage / over current	b008	00	Tripping
		01	Restarting the motor with 0 Hz at retry
		02	Starting the motor with an active matching frequency at retry.
		03	Starting the motor with an active matching frequency at retry. The inverter trips after decelerating and stopping the motor.
Selection of retry count after overvoltage or overcurrent	b010	1 to 3 (times)	Number of retries to be made after the occurrence of overvoltage or overcurrent (*4)
Retry wait time after overvoltage or overcurrent	b011	0.3 to 100. (s)	Time to wait until restarting the motor
Active frequency matching, scan start frequency	b028	"0.20 x rated current" to "2.00 x rated current"	Current limit for restarting with active matching frequency
Active frequency matching, scan-time constant	b029	0.1 to 3000.0 (s)	Duration of frequency lowering when restarting with active matching frequency
Active frequency matching, restart frequency select	b030	00	Frequency set when the inverter output has been shut off
		01	Maximum frequency
		02	Newly set frequency

Chapter 7 Explanation of Functions

- *1 If the inverter trips because of overvoltage or overcurrent while decelerating the motor, the inverter will display error code "E09" (undervoltage), and the motor will start free-running. If this error occurs, prolong the deceleration time.
- *2 The inverter may start the motor with 0 Hz if:
 - 1) the output frequency is not more than half the base frequency or
 - 2) the voltage induced on the motor is attenuated quickly.
- *3 Even when a retry operation (01 to 03) is specified for the selection of restart mode (b001) and "disabling tripping" (00 or 02) is specified for the selection of a trip after undervoltage in the stopped state (b004), the inverter will trip if the undervoltage failure continues over the allowable under-voltage power failure time (b002). (See example 2.)
When restart mode (b001) = Trip (00), the inverter will not trip if the undervoltage failure continues over the allowable under-voltage power failure time (b002).
- *4 Even when a retry operation is specified for the trip selection, the inverter will trip if the cause of trip is not removed by the end of the retry wait time before motor restart (b003). If this occurs, prolong the retry wait time.
- *5 Even when a retry operation is specified for the retry selection, the inverter will trip if the undervoltage status continues for 40 seconds or more.
- *6 when starting the motor with active matching frequency is selected, inverter may restart suddenly by alarm resetting, resetting and retry-start.

The figures below show the timing charts for starting with a matching frequency (when "02" is specified for the selection of restart mode [b001]).

t0: Duration of instantaneous power failure

t1: Allowable under-voltage power failure time (b002)

t2: Retry wait time before motor restart (b003)

(Example 1)

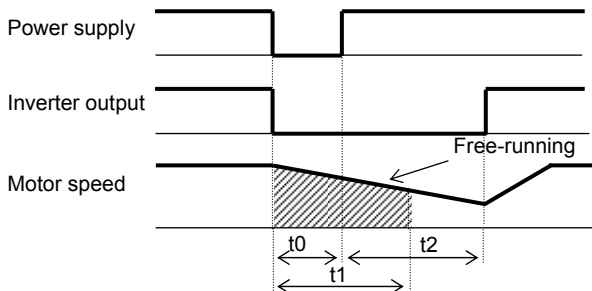

(Example 2)

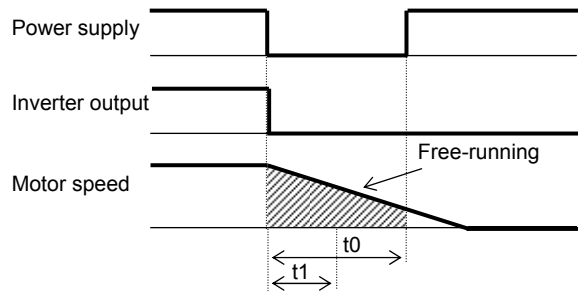

(Example 3) When the motor frequency (speed) is more than the setting of "b007" (b030=00):

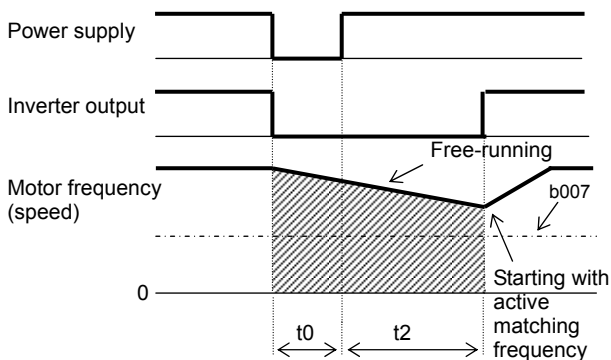

(Example 4) When the motor frequency (speed) is less than the setting of "b007" (b030=00):

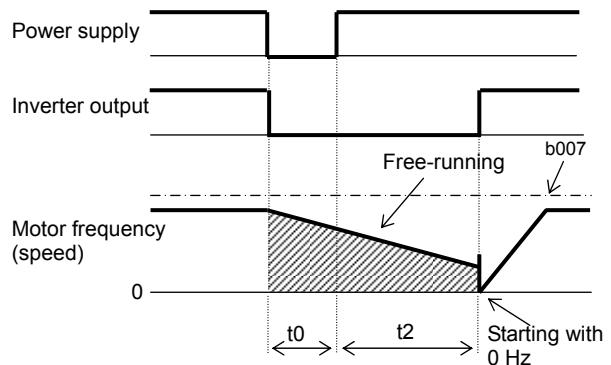

(2) Output of the alarms for undervoltage in the stopped state

Use function "b004" to specify whether to output an alarm when undervoltage occurs. The inverter outputs the alarm providing the control power remains in the inverter.

Output of the alarms for undervoltage in the stopped state:

Examples 5 to 7 show the alarm output operations with standard settings.

Example 5 b004=00

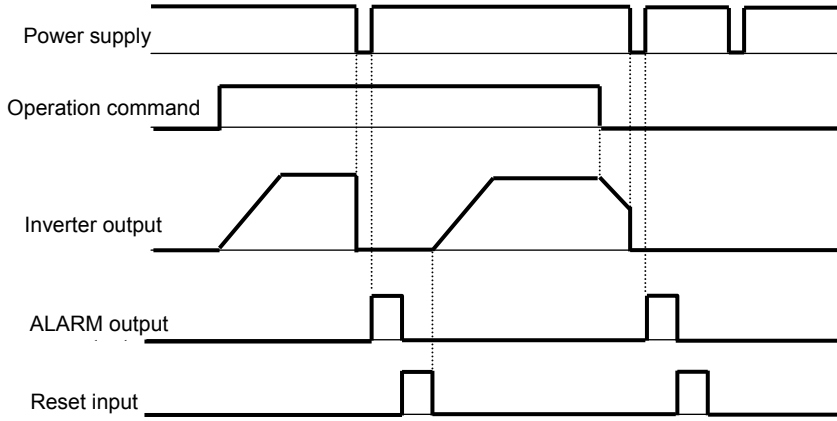

Example 6 b004=01

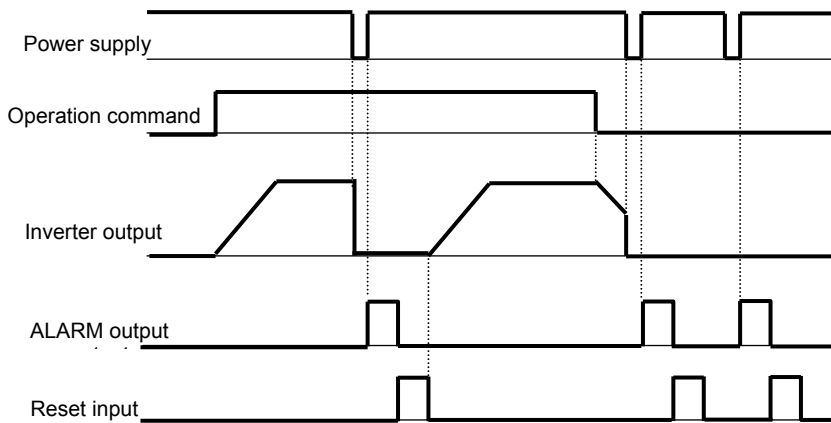

Example 7 b004=02

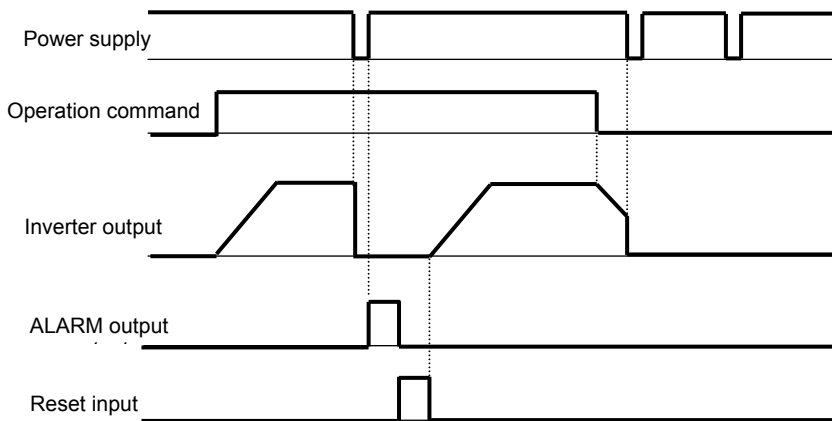

Chapter 7 Explanation of Functions

(3) Restarting methods

- Restart with an active matching frequency

The inverter starts the output with the frequency specified for the start frequency selection (b030), searches for the point where the frequency and voltage are balanced while keeping the current at the restart current level (b028), and then restarts the motor.

If the inverter trips when it restarts the motor in this way, reduce the setting of "b028".

- After the inverter output has been shut off, the digital operator continues to display until the inverter restarts the motor operation.

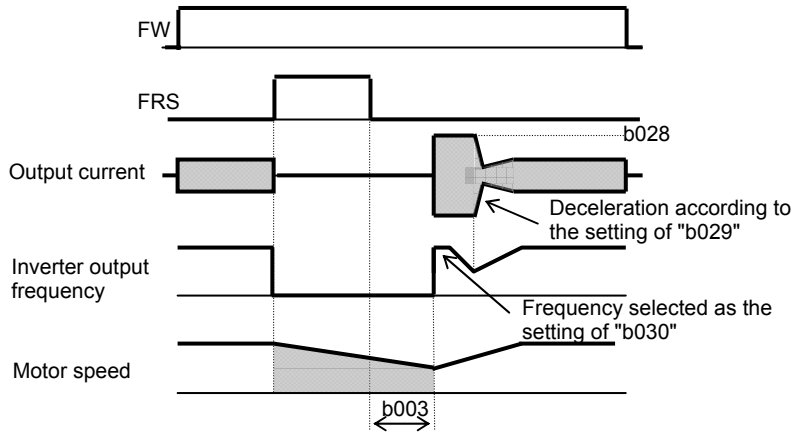

7.7.2 Reset (RS) function

The reset function allows you to recover the inverter from a tripped state.

To perform resetting, press the STOP/RESET key of the digital operator or turn the RS terminal ON.

To use the control circuit terminal for resetting, assign function "18" (RS) to an intelligent input terminal. You can select the restart mode to apply after resetting with the restart mode after reset (C103). When C102 =02, starting with 0 Hz is selected regardless to C103 setting.

If the inverter trips because of overcurrent when it starts the motor with matching frequency, increase the retry wait time before motor restart (b003).

You can select the alarm reset timing with the reset mode selection (C102). You can also enable the reset signal to be output only when resetting an error alarm.

The RS terminal can be configured only as an a-contact (NO).

Do not use the RS terminal for the purpose of shutting off the inverter output. The reset operation clears the electronic thermal data in the inverter, and, without this data, the inverter may be damaged during operation.

Item	Function code	Data or range of data	Description
Retry wait time before motor restart	b003	0.3 to 100. (s)	Time to wait after reset until restarting the motor
Restart frequency threshold	b007	0.00 to 400.0 (Hz)	Restarting the motor with 0 Hz if the frequency becomes less than the frequency set here during motor free-running.
Reset mode selection	C102	00	Resetting the trip when the RS signal is turned on (See example 1.) (When operation is normal) Shutting off the inverter output (When an error has occurred) Resetting the trip
		01	Resetting the trip when the RS signal is turned off (See example 2.) (When operation is normal) Shutting off the inverter output (When an error has occurred) Resetting the trip
		02	Resetting the trip when the RS signal is turned on (See example 1.) (When operation is normal) Disabling the inverter output (When an error has occurred) Resetting the trip
Restart mode after reset	C103	00	Start with 0 Hz
		01	Start with active matching frequency (See example 3.)

(Example 1)

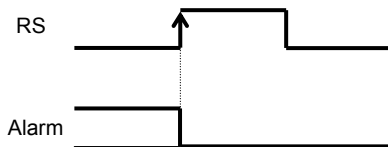

(Example 2)

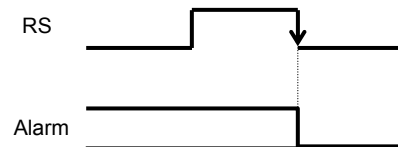

(Example 3) Restarting with active matching frequency

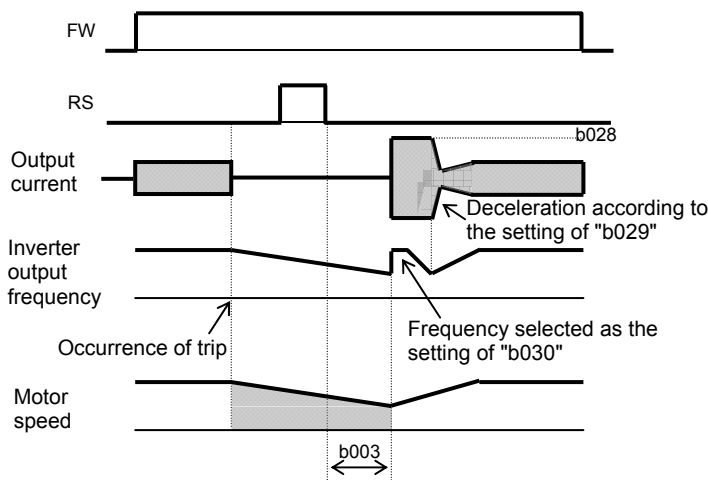

After the retry wait time (b003), the inverter restarts the motor with the frequency set as "b030". The inverter subsequently decelerates the motor according to the setting of "b029" while maintaining the output current at the level specified for "b029".

When the output voltage matches the frequency, the inverter re-accelerates the motor up to the frequency that was set when the inverter shut off the output to the motor before the restart.

If the inverter trips because of overcurrent when it restarts the motor with input frequency, reduce the setting of "b028".

(note) Inverter starts from 0Hz when reset signal is given during retry waiting because the frequency stored in inverter is cleared.

Chapter 7 Explanation of Functions

7.7.3 Free-run stop (FRS) function

The free-run stop (FRS) function allows you to shut off the inverter output to let the motor start free-running.

You can effectively use this function when stopping the motor with a mechanical brake (e.g., electromagnetic brake). If an attempt is made to forcibly stop the motor with a mechanical brake while the inverter keeps its output, the inverter may trip because of overcurrent.

To use this function, assign function "11" (FRS) to one of the terminal [1] to [5] functions (C001 to C005). The free-run stop (FRS) function operates as long as the FRS terminal is on. When the FRS terminal is turned off, the inverter restarts the motor after the retry wait time (b003). However, the inverter does not restart the motor if the digital operator (O2) has been specified for the run command source setting (A002). To restart the motor in such status, enter a new operation command.

You can select the inverter output mode for restarting with the restart mode after FRS (b088) from starting the motor with 0 Hz and restarting with active matching frequency. (See examples 1, 2.)

Even when restarting with active matching frequency has been selected, the inverter restarts the motor with 0 Hz if it detects a frequency lower than the restart frequency threshold (b007).

The settings, including that of the FRS terminal, which you make for this function will affect the inverter operation at recovery of the motor from the free-running status.

Item	Function code	Data or range of data	Description
Restart mode after FRS	b088	00	Start with 0 Hz (See example 1.)
		01	Restart with active matching frequency (See example 2.)
Retry wait time before motor restart	b003	0.3 to 100. (s)	Time to wait until restarting the motor
Restart frequency threshold	b007	0.00 to 400.0 (Hz)	Setting of the minimum level for frequency adjustment
Active frequency matching, scan start frequency	b028	"0.20 x rated current" to "2.00 x rated current"	Current limit for restarting with active matching frequency
Active frequency matching, scan-time constant	b029	0.10 to 3000.0 (s)	Duration of frequency lowering when restarting with active matching frequency
Active frequency matching, restart frequency select	b030	00	Frequency set when the inverter output has been shut off
		01	Maximum frequency
		02	Newly set frequency

(Example 1) Restarting with 0 Hz

(Example 2) Restarting with active matching frequency

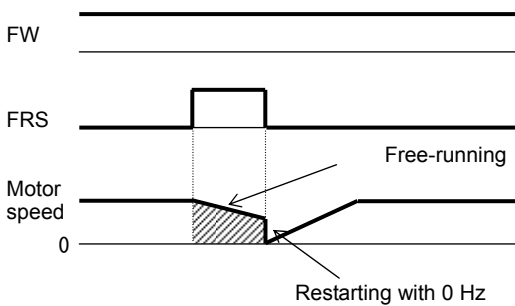

The inverter restarts the motor with 0 Hz regardless of the motor speed. The setting of retry wait time is ignored. If the inverter restarts the motor with 0 Hz when the motor speed is high, the inverter may trip because of overcurrent.

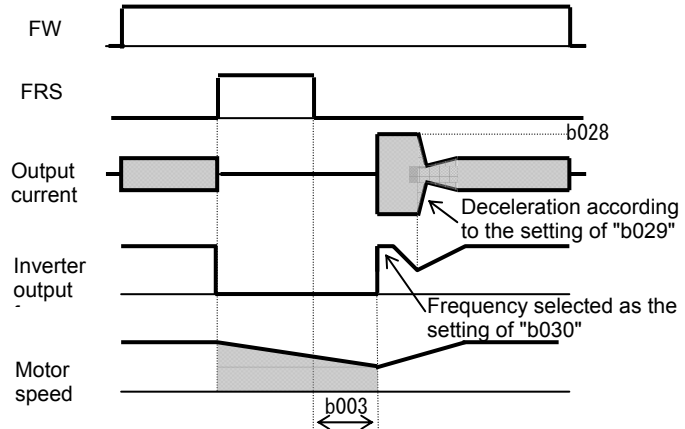

After the retry wait time (b003), the inverter restarts the motor with the frequency set as "b030". The inverter subsequently decelerates the motor according to the setting of "b029" while maintaining the output current at the level specified for "b029". When the output voltage matches the frequency, the inverter re-accelerates the motor up to the frequency that was set when the inverter shut off the output to the motor before the restart. If the inverter trips because of overcurrent when it restarts the motor with input frequency, reduce the setting of "b028".

7.7.4 Unattended start protection (USP) function

The unattended start protection function allows you to make the inverter trip with error code "E13" displayed if the inverter power is turned on when an operation command has been turned on. You can recover the inverter from tripping by performing the reset operation or turning the operation command off. (See example 1.)

If the inverter is recovered from tripping with the operation command left turned on, the inverter will start operation immediately after recovery. (See example 2.)

The inverter can operate normally when an operation command is turned on after the inverter power is turned on. (See example 3.)

To use this function, assign function "13" (USP) to one of the terminal [1] to [5] functions (C001 to C005). This function is invalid with the standard operation panel (RUN/STOP/RESET key).

When it is input a run command from the operator or Modbus within two seconds after the power supply injection, the inverter trip(E13).

The following charts show examples of the timing of the unattended start protection operation:

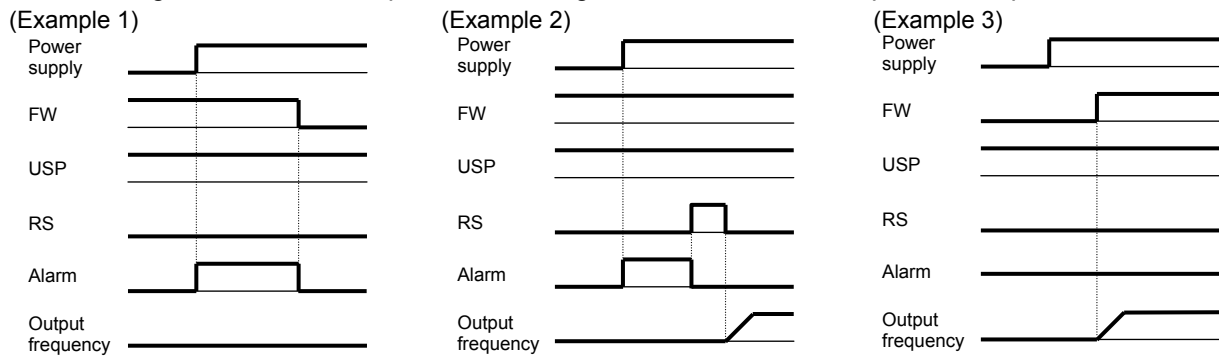

Item	Function code	Data	Description
Terminal [1] to [5] functions	C001 to C005	13	USP: Unattended start protection

Chapter 7 Explanation of Functions

7.7.5 Deceleration and stopping at power failure (nonstop deceleration at instantaneous power failure)

The nonstop deceleration at instantaneous power failure is the function making the inverter decelerate and stop the motor while maintaining the voltage below the overvoltage level when an instantaneous power failure occurs during the inverter operation.

You can select three modes with controller deceleration and stop on power loss (b050).

Item	Function code	Data or range of data	Description
Controller deceleration and stop on power loss	b050	00	Disabling the nonstop deceleration function
		01	Enabling the nonstop deceleration function (DEC & STOP)
		02	Enabling the nonstop deceleration function (DC voltage constant control, no restoration)
		03	Enabling the nonstop deceleration function (DC voltage constant control, Restoration to be done)
DC bus voltage trigger level during power loss	b051	0.0 to 400.0 (V)	Selectable on 200 V class inverter models
		0.0 to 800.0 (V)	Selectable on 400 V class inverter models
Over-voltage threshold during power loss (*1)	b052	0.0 to 400.0 (V)	Selectable on 200 V class inverter models
		0.0 to 800.0 (V)	Selectable on 400 V class inverter models
Deceleration time setting during power loss	b053	0.01 to 300.0 (s)	
Initial output frequency decrease during power loss	b054	0.00 to 10.00 (Hz)	

<1> nonstop deceleration at instantaneous power failure (b050=01)

- The nonstop deceleration at instantaneous power failure is the function making the inverter decelerate and stop the motor while maintaining the voltage below the overvoltage level (over-voltage threshold during power loss [b052]) when an instantaneous power failure occurs during the inverter operation.
- If an instantaneous power failure has occurred while the inverter is operating the motor and the output voltage falls to the DC bus voltage trigger level during power loss (b051) or less, the inverter reduces the output frequency by the initial output frequency decrease during power loss (b054) once, and then decelerates the motor for the deceleration time setting during power loss (b053).
- If the voltage increases to an overvoltage level (exceeding the over-voltage threshold during power loss [b052]) because of regeneration, the inverter enters the LAD stop state until the voltage falls below the overvoltage level.

Note1: If the over-voltage threshold during power loss (b052) is less than the DC bus voltage trigger level during power loss (b051), the over-voltage threshold during power loss will be increased to the DC bus voltage trigger level during power loss when the stop level is applied. (However, the stored setting will not be changed.)

And, in case b052 is less than the supply voltage (equivalent to rectified DC voltage which is square root 2 times supply AC voltage), when power recovers while this function is activated, inverter will be in the LAD stop status and cannot decelerate. (Stop command and frequency change command are not accepted until deceleration is completed). Be sure to set b052 more than the standard supply voltage.

Note2: This nonstop deceleration function cannot be canceled until the nonstop deceleration operation is completed. To restart the inverter operation after power recovery, wait until the inverter stops, enter a stop command, and then enter an operation command.

Note3: Setting higher initial output frequency decrease during power loss (b054) results in over current trip due to sudden deceleration. Setting lower b054, or longer deceleration time during power loss (b053) results in undervoltage trip due to less regeneration power.

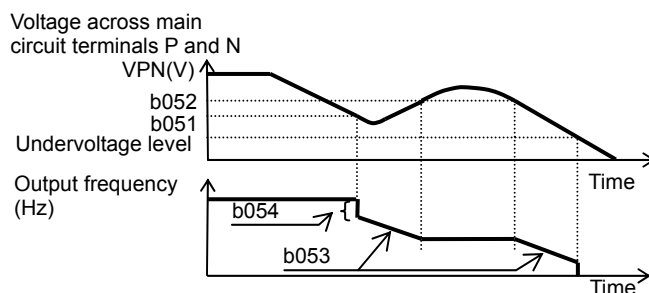

<2> DC voltage constant control during nonstop operation at momentary power failure (b050 = 02: no restoration, b050 = 03: restoration to be done)

- If momentary power failure occurs or the main circuit DC voltage drops during inverter operation, the inverter decelerates the motor while maintaining the main circuit DC voltage at the level specified as the target nonstop operation voltage at momentary power failure (0V-LAD stop level) (b052).
- This function starts operating when all the following conditions are met:
 - "02" or "03" has been specified for b050.
 - The inverter is running. (This function does not operate if the inverter has been tripped, is in undervoltage status or stopped.)
 - The control power fails momentarily or the main circuit DC voltage drops to the DC bus voltage trigger level during power loss (b051) or less.
- If momentary power failure only lasts a short time, the inverter can continue operation without stopping its output. Conversely, if momentary power failure causes undervoltage, the inverter stops its output immediately and ends the operation of this function. When power is subsequently restored, the inverter operates according to the selection of restart mode (b001).
- When "03" is specified for b050, the inverter can be restored to normal operation if the input power is recovered from momentary power failure before the inverter stops its output. The inverter, however, may decelerate and stop the motor if a specific setting has been made for b051. The table below lists the differences in operation according to the setting of b051.

b050	b051	Operation
02 (No restoration)	b052 > Main circuit DC voltage at input power recovery	Decelerating and stopping the motor (DC voltage constant control) (Example 1)
	b052 < Main circuit DC voltage at input power recovery	Decelerating and stopping the motor (Example 2)
03 (Restoration to be done)	b052 > Main circuit DC voltage at input power recovery	Decelerating and stopping the motor (DC voltage constant control) (Example 1)
	b052 < Main circuit DC voltage at input power recovery	Decelerating and stopping the motor (Example 2)

- When this function operates and the inverter decelerates and stops the motor, the motor is forcibly stopped even if the FW signal is on. To restart the motor, turn on the FW signal again after confirming the recovery of inverter input power.

Note 4: Each of the values of b051 and b052 must be the undervoltage 175V(200V class),350V(400V class)level or more. This function does not operate when undervoltage occurs. The value of b051 must be less than that of b052.

Note 5: When "02" or "03" is specified for b050, PI control is performed so that the internal DC voltage is maintained at a constant level. PI-gain (P-Gain,I-Gain) can adjust by b133(P) and b134(I).

(Example 1)

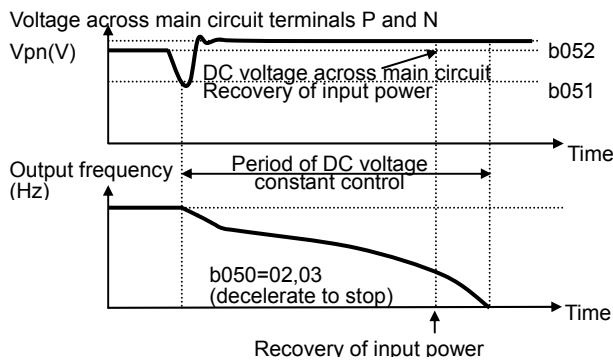

(Example 2)

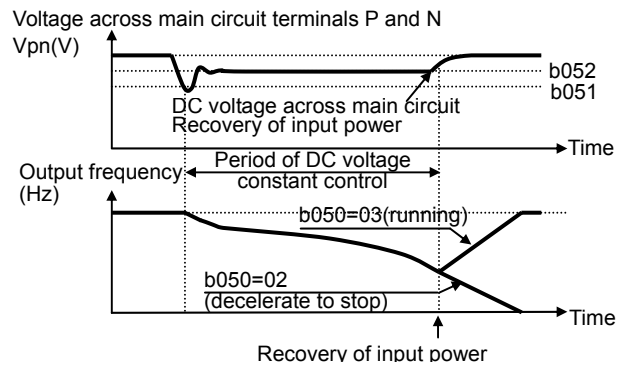

Chapter 7 Explanation of Functions

7.8 Set functions related to protection and warning, each output signal

7.8.1 Trip signal (AL)

When it detects an anomaly, the inverter output is shut off, the inverter outputs a trip signal. This is called a trip.

If you reset, the inverter deactivate trip state. Trip signal is turned OFF at the same time. How to Reset.

- 1) Pressing the STOP/RESET key.
 - 2) To use the reset terminal (18:RS).
- (Part of the cause of trip can not be released by a reset. In this case, it is required a power cycle.)

Trip signal(05:AL) is assigned to the output terminal 11(C021) or Alarm relay (C026).

(Initial data C026 = 05[AL])

Alarm relay contacts are 1c.(Refer to 7.3.5)

Item	Function code	Data	Description
Output [11] function	C021	05	AL : Trip signal
Alarm relay function	C026		
Terminal [1] to [5] functions	C001 to C005	18	RS : Reset signal

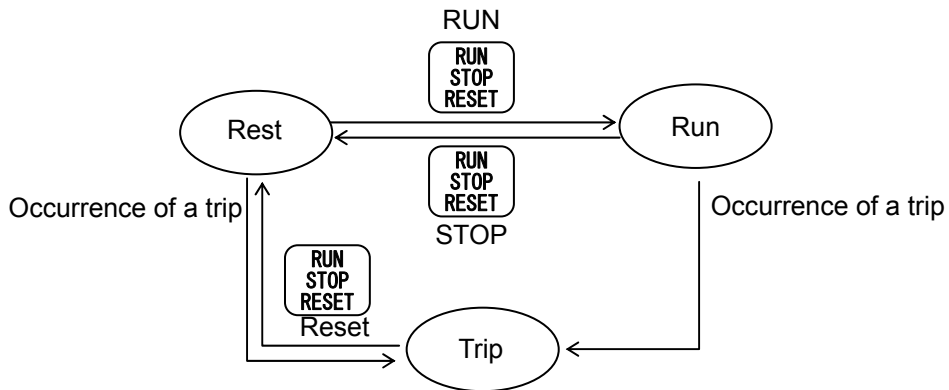
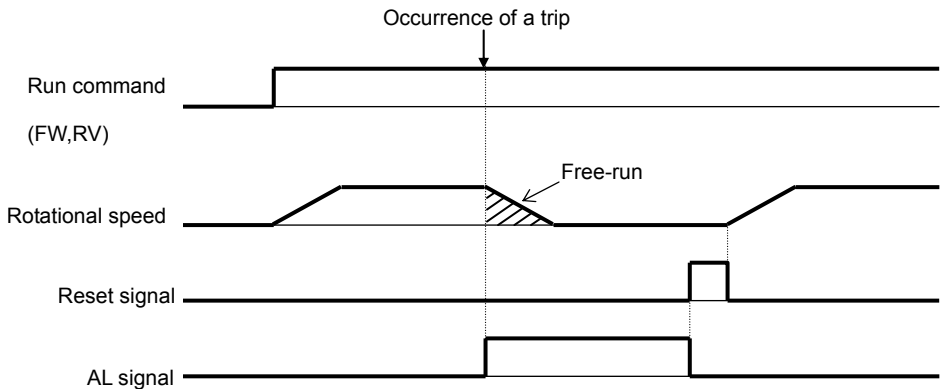

7.8.2 Electronic thermal protection

The electronic thermal protection function allows you to protect the motor against overheating. Make settings of this function based on the rated current of the motor. The inverter will trip for overheat protection according to the settings.

This function provides optimum overheat protection that is also designed with the lowering of the motor's cooling performance at low speeds in mind.

You can configure this function so that the inverter outputs a warning signal before it trips for electronic thermal protection.

(1) Electronic thermal level

Item	Function code	Range of data	Description
Electronic thermal setting (calculated within the inverter from current output)	b012/b212	"0.2 x rated current" to "1.0 x rated current"	See the example below.

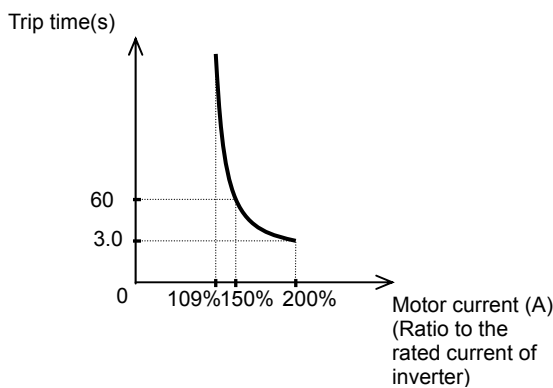

(2) Electronic thermal characteristic

The frequency characteristic set as the electronic thermal characteristic is integrated with the value of "b012" or "b212".

The cooling-fan performance of a general-purpose motor lowers when the motor speed is low. So load (current) is decreased.

The reduced-torque characteristic is designed to match the heat generation by Hitachi's general-purpose motors.

Item	Function code	Data	Description
Electronic thermal characteristic	b013/b213	00	Reduced-torque characteristic
		01	Constant-torque characteristic
		02	Free setting of electronic thermal characteristic

(a) Reduced-torque characteristic

The time-limit characteristic determined by the value of "b012" or "b212" is integrated with each frequency multiplied by reduction scales.

(Example) 015L**, Base frequency 60Hz, (rated current 7.1A = b012)

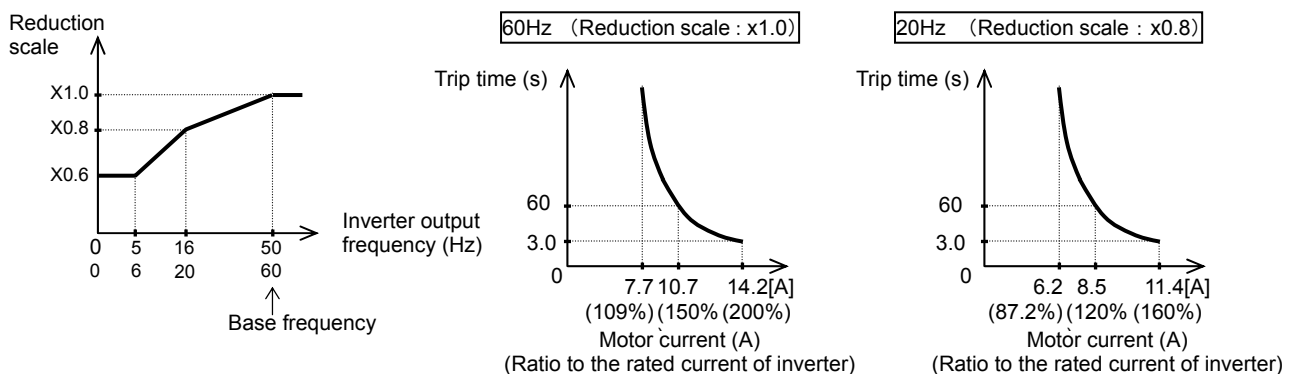

Chapter 7 Explanation of Functions

(b) Constant-torque characteristic

Make this setting when driving a constant-torque motor with the inverter.

(Example) 015L**, Base frequency 60Hz, (rated current 7.1A = b012)

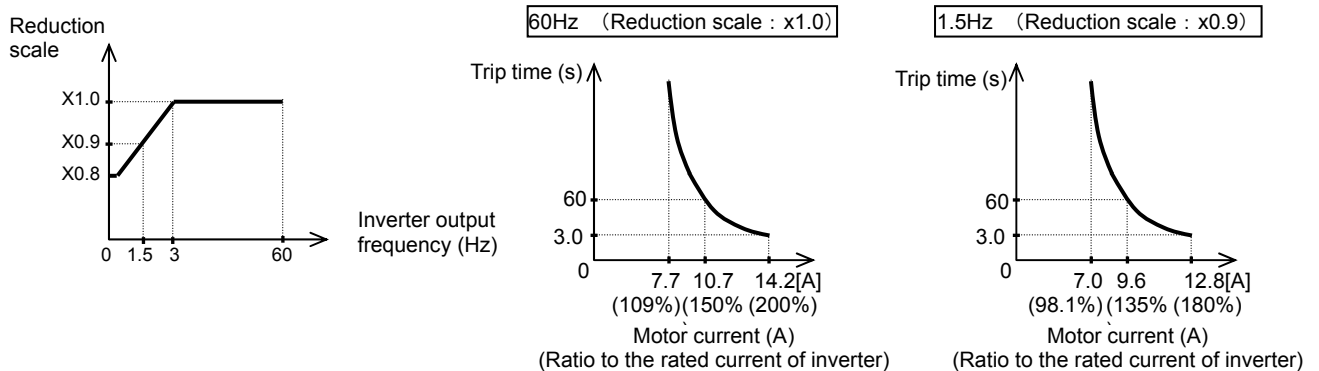

(c) Free setting of electronic thermal characteristic

To protect the motor against overheating, you can set the electronic thermal characteristic freely according to the load on the motor.

The range of setting is shown in the figures below.

Item	Function code	Range of data	Description
Free setting, electronic thermal frequency (1) (2) (3)	b015/b017/ b019	0. to 400. (Hz)	Setting of frequency at each breakpoint
Free setting, electronic thermal current (1) (2) (3)	b016/b018/ b020	"0.2 x rated current" to "1.0 x rated current"	Setting of the current at each breakpoint

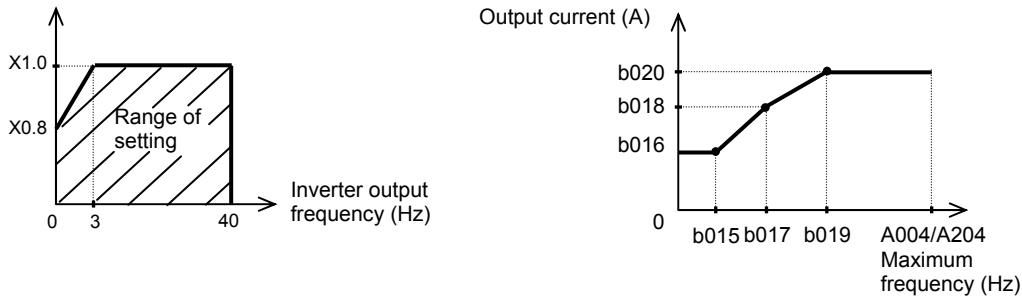

(3) Thermal warning

You can configure this function so that the inverter outputs a warning signal before the electronic thermal protection operates against motor overheat. You can also set the threshold level to output a warning signal with the electronic thermal warning level setting (C061).

To output the warning signal, assign function "13" (THM) to one of the intelligent output terminal [11] (C021) and the alarm relay terminal (C026).

And electronic thermal overload monitor is displayed on "d104".

Item	Function code	Data	Description
Electronic thermal warning level setting	C061	0.	Disabling the warning output
		1. to 100. (%) (*1)	Setting of the threshold level to output the thermal warning signal

*1 Set the ratio (%) of the warning level to the integrated value of the electronic thermal characteristic. A setting of 100% corresponds to the inverter trip due to overload (error code "E05").

7.8.3 Overload restriction/overload notice

(1) Overload restriction function

- The overload restriction function allows you to make the inverter monitor the motor current during acceleration or constant-speed operation and automatically reduce the output frequency according to the deceleration rate at overload restriction when the motor current reaches the overload restriction level.
- This function prevents the moment of inertia from excessively increasing during motor acceleration and prevents the inverter from tripping because of overcurrent, even when the load changes suddenly during the constant-speed operation of the motor.
- You can specify two types of overload restriction operation by setting functional items "b021", "b022", and "b023" and functional items "b024", "b025", and "b026" separately.
- To switch the overload restriction operation between the two settings (setting with b021, b022, and b023 and setting with b024, b025, and b026), assign function "39" (OLR) to an intelligent input terminal. Turn the OLR signal on and off to switch between the two settings.
- The overload restriction level specifies the current at which to trigger the overload restriction function.
- The deceleration rate at overload restriction specifies the length of time to decelerate the motor from the maximum frequency to 0 Hz.
- When this function operates during deceleration, the acceleration time is prolonged over the set time.
- If the value set as the deceleration rate at overload restriction (b023/b223/b026) is too small, the inverter automatically decelerates the motor even during acceleration because of the overload restriction, and may trip because of the overvoltage caused by the energy regenerated by the motor.
- If this function operates during acceleration and the output frequency cannot reach the target frequency, try to make the following adjustments:
 - Increase the acceleration time.
 - Increase the overload restriction setting (b022/b222/b025).

Item	Function code	Data or range of data	Description
Overload restriction operation mode	b021/b221 b024	00	Disabling the overload restriction
		01	Enabling the overload restriction during acceleration and constant-speed operation
		02	Enabling the overload restriction during constant-speed operation
Overload restriction setting	b022/b222 b025	"Rated current x 0.2" to "rated current x 2.0" (A)	Current at which to trigger the overload restriction
Deceleration rate at overload restriction	b023/b223 b026	0.1 to 3000. (s)	Deceleration time to be applied when the overload restriction operates
Terminal function	C001 to C005	39	Terminal to switch the overload restriction setting

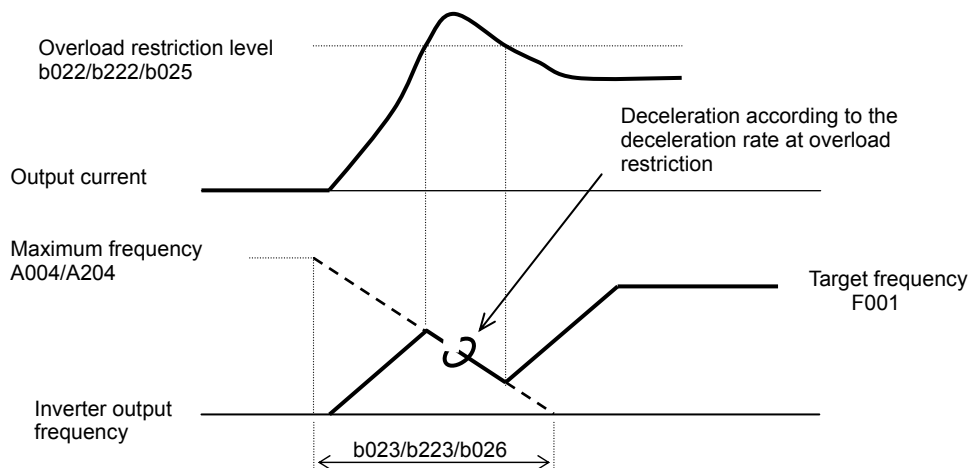

Chapter 7 Explanation of Functions

(2) Overload notice function

The overload notice function allows you to make the inverter output an overload notice signal before tripping because of overload.

You can use this function effectively to prevent the machine (e.g., a conveyor) driven by the inverter from being overloaded and prevent the conveyor from being stopped by the overload protection of the inverter. To use this function, assign function "03" (OL) to one of the intelligent output terminal [11] (C021) and the alarm relay terminal (C026).

Item	Function code	Data or range of data	Description
Overload signal output mode	C040	00	Enabling the warning output during acceleration, deceleration, and constant
		01	Enabling the warning output during constant
		0.0	Disabling the warning output
Overload level setting	C041/C241	0.0 to "2.0 x rated current" (A)	Specifying the current at which to output the OL signal (overload notice advance signal).

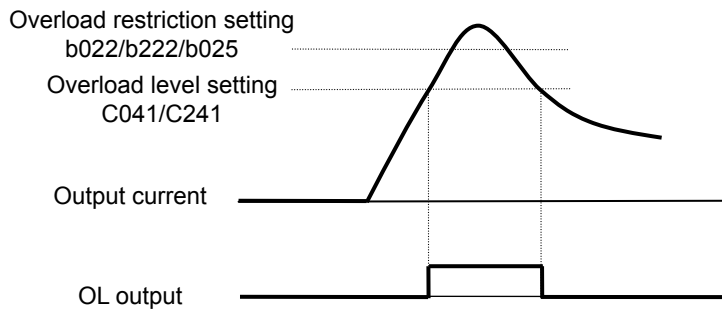

7.8.4 Overcurrent restraint [b027]

The overcurrent restraint function allows you to restrain the overcurrent that can occur when the output current sharply increases because of rapid acceleration.

You can enable or disable the function by setting the overcurrent suppression enable (b027).

Item	Function code	Data or range of data	Description
Overcurrent suppression enable	b027	00	Disabling the overcurrent restraint
		01	Enabling the overcurrent restraint

Note: When using the inverter for a lift, disable the overcurrent restraint function. If the overcurrent restraint functions during the lift operation, the lift may slide down because of insufficient torque.

Note: When an acceleration time is extremely short for the load, overcurrent trip may occur. In this case please adjust an acceleration time.

Note: In the case of Disabling the overcurrent restraint, may become Inverter Trip at the time of Overcurrent restraint function movement depending on a motor.

7.8.5 Over voltage suppression during deceleration

- The over voltage suppression function allows you to prevent the inverter from tripping because of the overvoltage that can be caused by the energy regenerated by the motor during deceleration.
- You can enable or disable the function by setting the overvoltage suppression enable (b130).
- When "01" (enabling the over voltage suppression [with deceleration stop]) is specified for the overvoltage suppression enable (b130), the inverter will decelerate by keeping the voltage of the main circuit DC section at over voltage suppression level (b131).
- When "02" (enabling the overvoltage suppression [with acceleration]) is specified for the overvoltage suppression enable (b130), the inverter will start acceleration according to the acceleration and deceleration rate at overvoltage suppression (b132) if the voltage of the main circuit DC section exceeds the overvoltage suppression level (b131). Subsequently, the inverter will restart deceleration when the voltage falls below the level (b131).

Item	Function code	Data or range of data	Description
Overvoltage suppression enable	b130	00	Disable
		01	Enabling the overvoltage suppression (with controlled deceleration) (See example 1.) (note5)
		02	Enabling the overvoltage suppression (with acceleration) (See example 2.)
		03	Enabling the overvoltage suppression (It is effective at the constant/deceleration)
Overvoltage suppression level (See Note 4.)	b131	330 to 390 (V)	Level setting for 200 V class models
		660 to 780 (V)	Level setting for 400 V class models
Acceleration rate at overvoltage suppression	b132	0.10 to 30.00 (s)	Specifying the acceleration rate to be applied when the function is enabled (valid when b130=02)
Overvoltage suppression proportional gain	b133	0.00 to 5.00	Overvoltage suppression proportional gain setting (valid when b130=01)
Overvoltage suppression integral time	b134	0.0 to 150.0 (s)	Overvoltage suppression integral time setting (valid when b130=01)

(Example 1) When "b130" is "01":

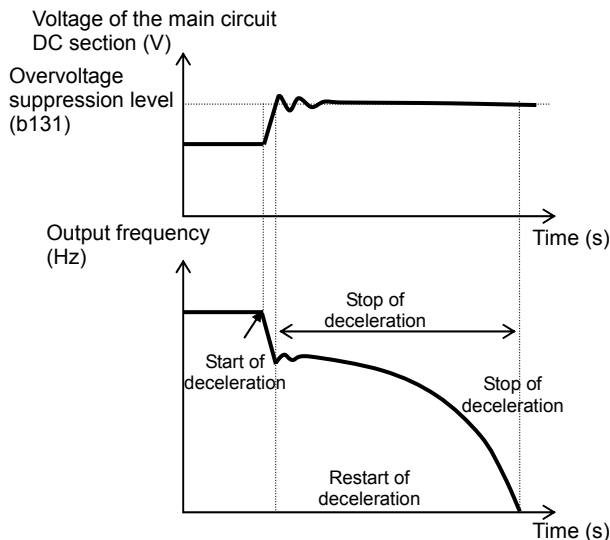

(Example 2) When "b130" is "02":

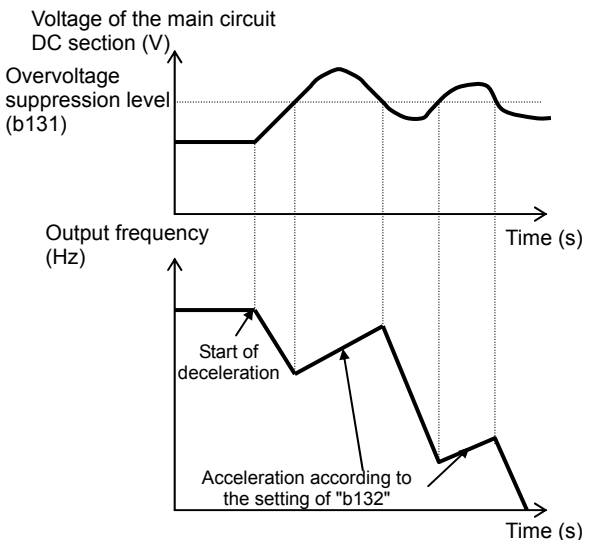

Note 1: When this function is enabled, the actual acceleration time may be prolonged over the set time.

Note particularly that the motor may not be decelerated if the setting of "b131" is too small when "02" or "03" is specified for the overvoltage suppression enable (b130).

Note 2: This overcurrent restraint function does not maintain the DC voltage at a constant level. Therefore, inverter trips due to overvoltage may be caused by the setting of the deceleration rate or by a specific load condition.

Note 3: When this function is enabled, the inverter may require a long time to decelerate and stop the motor if the load on the motor or the moment of inertia on the motor is under a specific condition.

Note 4: If a voltage lower than the input voltage is specified for b131, the motor cannot be stopped.

Note 5: When "01" is specified for b130, PI control is performed so that internal DC voltage is maintained at a constant level.

- Setting a higher proportional gain (b133) results in a faster response. However, an excessively high proportional gain causes control to diverge and results in the inverter easily tripping.

- Setting a shorter integral time (b134) results in a faster response. However, an excessively short integral time results in the inverter easily tripping.

Chapter 7 Explanation of Functions

7.8.6 External trip (EXT) function

The external trip function allows you to make the inverter trip according to the error (trip) signal generated by an external system.

To use this function, assign function "12" (EXT) to one of the terminal [1] to [5] functions (C001 to C005). When the EXT terminal is turned on, the inverter trips with error code "E12" displayed and stops the output.

After the inverter trips with error code "E12" displayed, it will not be recovered from tripping, even when the error signal from the external system is reset (i.e., the EXT terminal is turned off).

To recover the inverter from tripping, reset the inverter or turn the inverter power off and on.

Item	Function code	Data	Description
Terminal [1] to [5] functions	C001 to C005	12	EXT: External trip

Note: Do not turn on the EXT terminal after the inverter power is shut off. Otherwise, the error history may not be stored correctly.

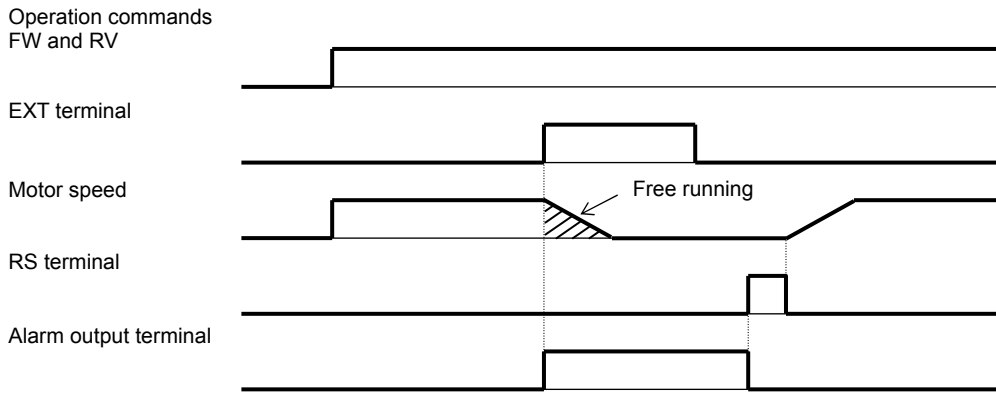

7.8.7 Automatic carrier frequency reduction [b089]

- The automatic carrier frequency reduction function automatically reduces the carrier frequency according to the increase in output current.
- To enable this function, specify "01" for automatic carrier frequency reduction selection (b089).

Item	Function code	Range of data	Description
Automatic carrier frequency reduction	b089	00/01/02	00: Disabled, 01: Enabled, depending on the output current, 02: Enabled, depending on the heat-sink temperature

- ex.) b089=01

When the output current increases to 60%, 72%, 84%, or 96% of the rated current, this function reduces the carrier frequency to 12, 9, 6, or 3 kHz, respectively. This function restores the original carrier frequency when the output current decreases to 5% lower than each reduction start level.

Carrier frequency reduction start level(Restoration level)		Carrier frequency after reduction (kHz)
Current dependence [b089=01]	Heat-sink temperature dependence [b089=02]	
Less than 60% of rated current	Less than 45°C	15.0
60% (55%) of rated current	45°C(40°C)	12.0
72% (67%) of rated current	55°C(50°C)	9.0
84% (79%) of rated current	65°C(60°C)	6.0
96% (91%) of rated current	75°C(70°C)	3.0

Action of b089 = 01

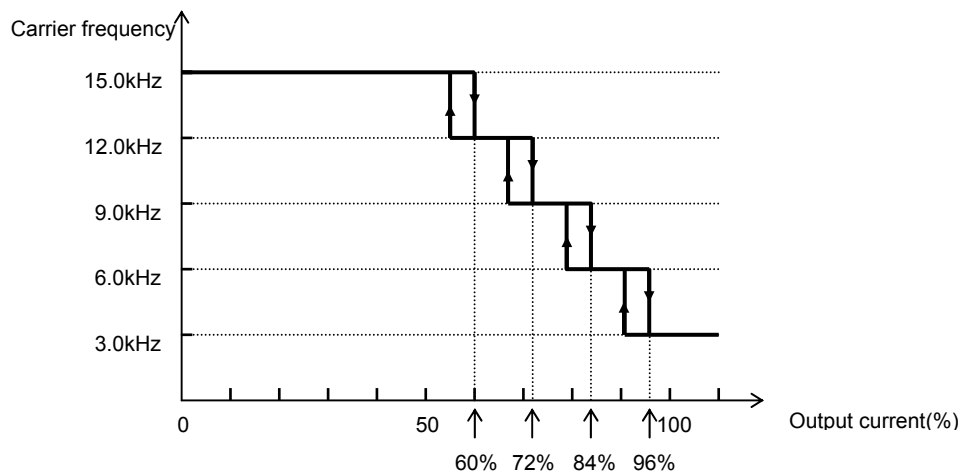

Action of b089 = 02

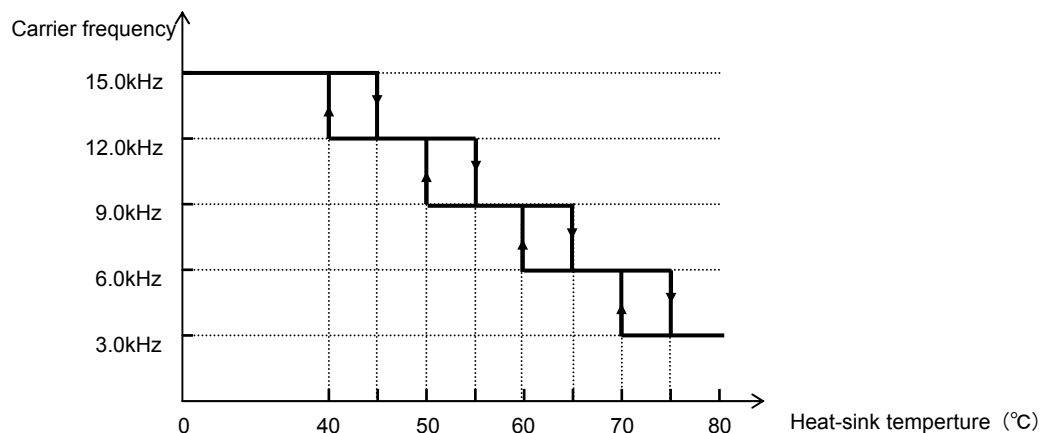

- The rate of carrier frequency reduction is 2 kHz per second.
- The maximum limit of carrier frequency change by this function is the value specified for the carrier frequency setting (b083); the minimum limit is 3 kHz. If 3 kHz or less frequency has been specified for b083, this function is disabled regardless of the setting of b089.

Chapter 7 Explanation of Functions

7.8.8 Running signal (RUN)

While the inverter is operating, it outputs the running (RUN) signal via an intelligent output terminal ([11]) or the alarm relay terminal.

To use this signal function, assign function "00" (RUN) to one of the intelligent output terminals [11] (C021) and the alarm relay terminal (C026).

The inverter outputs the RUN signal even while operating the DC brake. The following figure shows a timing chart for the signal output:

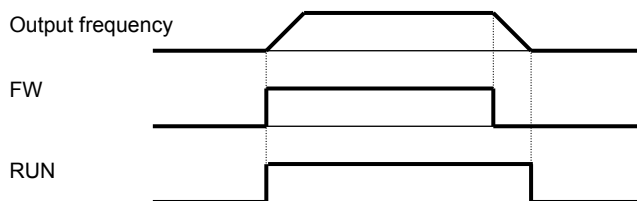

7.8.9 Frequency arrival signals (FA1, FA2, FA3)

The inverter outputs a frequency-arrival signal when the inverter output frequency reaches a set frequency. Assign the following functions to three of the intelligent output terminals [11] (C021) and the alarm relay terminal (C026):

"01" (FA1: constant-speed reached), "02" (FA2: set frequency overreached), "06" (FA3: set frequency reached)

The hysteresis of each frequency-arrival signal is as follows:

When the signal is on: ("set frequency" - "1% of maximum frequency") (Hz)

When the signal is off: ("set frequency" - "2% of maximum frequency") (Hz)

The signal hysteresis at acceleration with function "06" (FA3) set is as follows:

When the signal is on: ("set frequency" - "1% of maximum frequency") (Hz)

When the signal is off: ("set frequency" + "2% of maximum frequency") (Hz)

The signal hysteresis at deceleration with function "06" (FA3) set is as follows:

When the signal is on: ("set frequency" + "1% of maximum frequency") (Hz)

When the signal is off: ("set frequency" - "2% of maximum frequency") (Hz)

Item	Function code	Range of data	Description
Frequency arrival setting for accel.	C042	0.0 (Hz)	Disabling the output of frequency
		0.01 to 400.0 (Hz)	Enabling the output of frequency
Frequency arrival setting for decel.	C043	0.0 (Hz)	Disabling the output of frequency
		0.01 to 400.0 (Hz)	Enabling the output of frequency

(1) Signal output when the constant-speed frequency is reached (01: FA1)

The inverter outputs the signal when the output frequency reaches the frequency specified by a frequency setting (F001, A020, A220) or multispeed setting (A021 to A027).

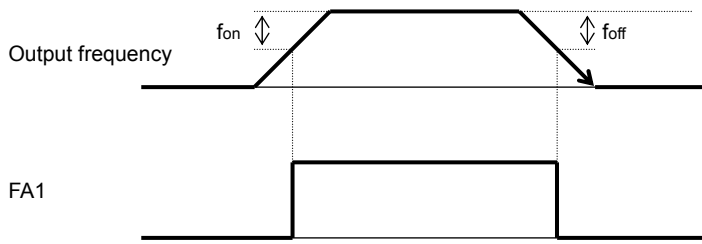

Set frequency {
 fon: 1% of maximum frequency
 foff: 2% of maximum frequency

(Example)

Maximum frequency (fmax) = 120 Hz

Set frequency (fset) = 60 Hz

fon = 120 x 0.01 = 1.2 (Hz)

foff = 120 x 0.02 = 2.4 (Hz)

At acceleration, the signal turns on when the output frequency reaches 58.8 Hz (60 - 1.2 = 58.8).

At deceleration, the signal turns off when the output frequency reaches 57.6 Hz (60 - 2.4 = 57.6).

(2) Signal output when the set frequency is exceeded (02: FA2)

The inverter outputs the signal when the output frequency exceeds the acceleration or deceleration frequency specified by a frequency setting ("C042" or "C043" [FA2]).

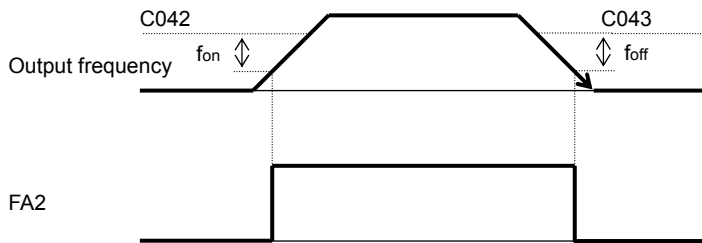

fon: 1% of maximum frequency
 foff: 2% of maximum frequency

(3) Signal output only when the set frequency is reached (06: FA3)

The inverter outputs the signal only when the output frequency reaches the frequency specified by a frequency setting ("C042" or "C043" [FA3]).

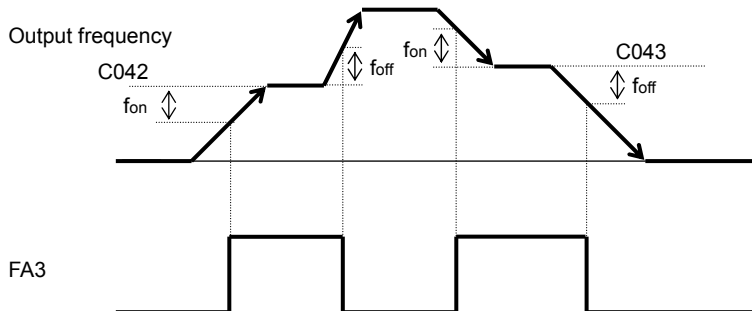

fon: 1% of maximum frequency
 foff: 2% of maximum frequency

Chapter 7 Explanation of Functions

7.8.10 Running time over and power-on time over signals (RNT and ONT) [b034]

The inverter outputs the operation time over (RNT) signal or the plug-in time over (ONT) signal when the time specified as the run/power-on warning time (b034) is exceeded.

Item	Function code	Range of data	Description
Run/power-on warning time	b034	0.	Disabling the signal output
		1. to 9999.	Setting in units of 10 hours (range: 10 to 99,990 hours)
		1000 to 6553	Setting in units of 100 hours (range: 100,000 to 655,300 hours)

(1) Operation time over (RNT) signal

To use this signal function, assign function "11" (RNT) to one of the intelligent output terminals [11] (C021) and the alarm relay terminal (C026).

Specify the run/power-on warning time (b034).

(2) Plug-in time over (ONT) signal

To use this signal function, assign function "12" (ONT) to one of the intelligent output terminals [11] (C021) and the alarm relay terminal (C026).

Specify the run/power-on warning time (b034).

7.8.11 0Hz speed detection signal (ZS)

The inverter outputs the 0 Hz speed detection signal when the inverter output frequency falls below the threshold frequency specified as the zero speed detection level (C063).

To use this signal function, assign function "21" (ZS) to one of the intelligent output terminals [11] (C021) and the alarm relay terminal (C026).

Item	Function code	Data or range of data	Description
Zero speed detection level	C063	0.00 to 100.0 (Hz)	Setting of the frequency to be determined as 0 Hz

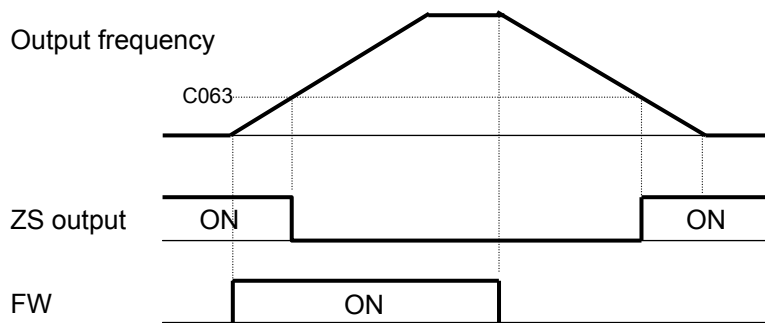

7.8.12 Logical output signal operation function (LOG1)

The logical output signal operation function allows you to make the inverter internally perform a logical operation of output signals.

This function applies to all output signals, except to logical operation results (LOG1) and allocation none (NO).

Three types of operators (AND, OR, and XOR) are selectable.

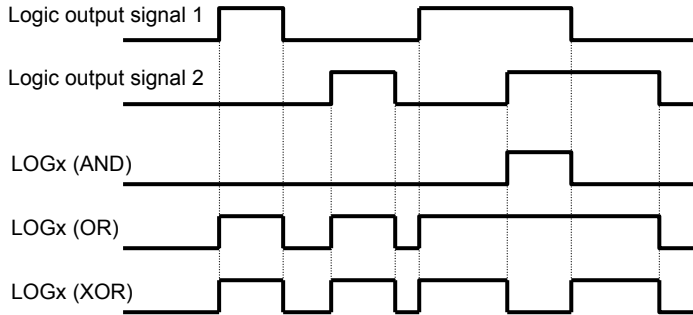

Selected signal	Operation-target 1 selection	Operation-target 2 selection	Operator selection
33: Logical output signal 1 (LOG1)	C142	C143	C144

(Example) To output the AND of the running signal (00: RUN) and set the frequency overreached signal (02: FA2) as the logical output signal 1 (LOG1) to the intelligent output terminal [11]:

- Intelligent output terminal [11] (C021): 33 (LOG1)
- Logical output signal 1 selection 1 (C142): 00 (RUN)
- Logical output signal 1 selection 2 (C143): 02 (FA2)
- Logical output signal 1 operator (C144): 00 (AND)

Item	Function code	Data or range of data	Description
Logical output signal selection 1	C142	Selection of "00" to "60" from the data (except LOG1,no) output to intelligent output terminals	Selection of operation-target 1
Logical output signal selection 2	C143	Selection of "00" to "60" from the data (except LOG1,no) output to intelligent output terminals	Selection of operation-target 2
Logical output signal operator selection	C144	00	AND
		01	OR
		02	XOR

Chapter 7 Explanation of Functions

7.8.13 Communication line disconnection signal (NDc)

This signal function is enabled when ModBus-RTU has been selected for the RS485 communication. If a reception timeout occurs, the inverter continues to output the communication line disconnection signal until it receives the next data.

Specify the limit time for reception timeout by setting the communication trip time (C077).

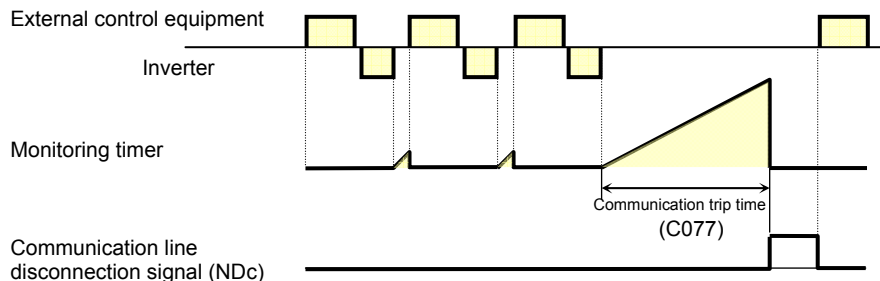

Item	Function code	Data or range of data	Description
Terminal function	C021	32	NDc: Communication line disconnection signal
Alarm relay terminal function	C026		
Communication trip time	C077	0.00 to 99.99 (s)	Setting of the limit time for reception timeout

7.8.14 Starting contact signal (FR)

The inverter outputs the starting contact (FR) signal while it is receiving an operation command.

The FR signal is output, regardless of the setting of the run command source setting (A002).

If the forward operation (FW) and reverse operation (RV) commands are input at the same time, the inverter stops the motor operation.

Item	Function code	Data	Description
Terminal function	C021	41	FR: Starting contact signal
Alarm relay terminal function	C026		

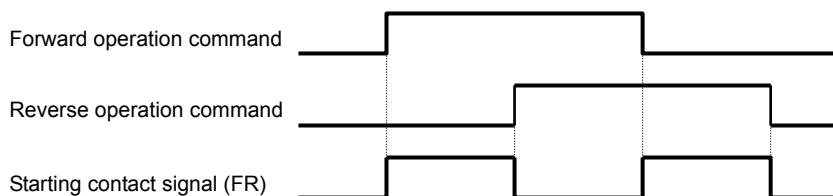

7.8.15 Heat sink overheating warning signal (OHF) [C064]

The inverter monitors the temperature of its internal heat sink, and outputs the heat sink overheating warning (OHF) signal when the temperature exceeds the heat sink overheating warning level (C064).

Item	Function code	Data or range of data	Description
Terminal function	C021	42	OHF: Heat sink overheating warning signal
Alarm relay terminal function	C026		
Heat sink overheating warning level	C064	0. to 110. (°C)	Setting of the threshold temperature at which to output the heat sink overheating warning signal

7.8.16 Low-current indication (LOC) signal

The inverter outputs the low-current indication (LOC) signal when the inverter output current falls to the low-current indication signal detection level (C039) or less.

You can select one of the two signal output modes with the low-current indication signal output mode selection (C038). In one mode, the LOC signal output is always enabled during the inverter operation. In the other mode, the LOC signal output is enabled only while the inverter is driving the motor for constant-speed operation.

Item	Function code	Data or range of data	Description
Terminal function	C021	43	LOC: Low-current indication signal
Alarm relay terminal function	C026		
Low-current indication signal output mode selection	C038	00	Enabling the signal output during operation
		01	Enabling the signal output only during constant-speed operation (*1)
Low-current indication signal detection level	C039	0.0 to "2.0 x rated current" (A)	Setting of the threshold current level at which to output the low-current indication signal

(*1) When 01 (control circuit terminal) is selected as frequency source setting (A001), there is a case that inverter does not recognize the speed as constant value due to sampling. In this case, adjusting is to be made by setting C038=00 (valid during operation) or increasing analogue input filter (A016).

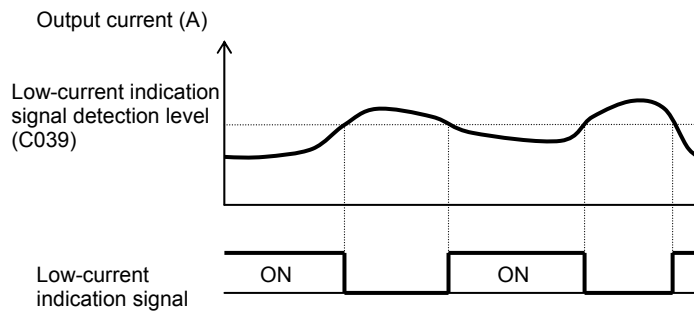

7.8.17 Inverter ready signal (IRDY)

The inverter outputs the inverter ready (IRDY) signal when it is ready for operation (i.e., when it can receive an operation command).

- The inverter can recognize only the operation command that is input while the IRDY signal is output.
- If the IRDY signal is not output, check whether the input power supply voltage (connected to the R, S, and T terminals) is within the range of specification.

Item	Function code	Data or range of data	Description
Terminal function	C021	50	IRDY: Inverter ready signal
Alarm relay terminal function	C026		

7.8.18 Forward rotation signal (FWR)

The inverter continues to output the forward rotation (FWR) signal while it is driving the motor for forward operation. The FWR signal is turned off while the inverter is driving the motor for reverse operation or stopping the motor.

Item	Function code	Data or range of data	Description
Terminal function	C021	51	FWR: Forward rotation signal
Alarm relay terminal function	C026		

Chapter 7 Explanation of Functions

7.8.19 Reverse rotation signal (RVR)

The inverter continues to output the forward rotation (RVR) signal while it is driving the motor for reverse operation.

The RVR signal is turned off while the inverter is driving the motor for forward operation or stopping the motor.

Item	Function code	Data or range of data	Description
Terminal function	C021	52	RVR: Reverse rotation signal
Alarm relay terminal function	C026		

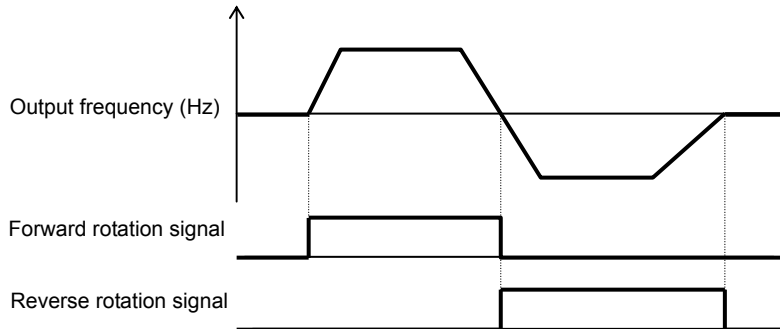

7.8.20 Major failure signal (MJA)

The inverter outputs the major failure (MJA) signal in addition to an alarm signal when it trips because of one of the errors listed below.

No.	Error code	Description
1	E08.*	Memory error
2	E10.*	Current detection error
3	E11.*	CPU error
4	E14.*	Ground-fault protection
5	E19.*	Inverter thermal detection system error

Item	Function code	Data or range of data	Description
Terminal function	C021	53	MJA: Major failure signal
Alarm relay terminal function	C026		

7.8.21 Window comparators (WC) (detection of terminal disconnection:Dc)

- The window comparator function outputs signals when the values of analog inputs O/OI is within the maximum and minimum limits specified for the window comparator. You can monitor analog inputs with reference to arbitrary levels (to find input terminal disconnection and other errors).
- You can specify a hysteresis width for the maximum-limit and minimum-limit levels of the window comparator.
- You can specify limit levels and a hysteresis width individually for analog inputs O/OI.
- You can fix the analog input data to be applied to an arbitrary value when WC is output. For this purpose, specify a desired value as the operation level at O/OI disconnection (b070). When "no" is specified, the analog input data is reflected as input.
- Output values of Dc is the same as those of WC respectively.

Item	Function code	Range of data	Description
Terminal [11] functions	C021 C026	27	Dc: Detection of analog input disconnection
Alarm relay terminal function		54	WC: Window comparator
Maximum-limit level of window comparators O/OI	b060	"Minimum-limit level + hysteresis width*2 (minimum of 0)" to 100. (%)	Setting of maximum-limit level
Minimum-limit level of window comparators O/OI	b061	0 to "maximum-limit level - hysteresis width*2 (maximum of 100)" (%)	Setting of minimum-limit level
Hysteresis width of window comparators O/OI	b062	0 to "(maximum-limit level - minimum-limit level)/2 (maximum of 10)" (%)	Setting of hysteresis width for maximum-limit and minimum-limit levels
Operation level at O/OI disconnection	b070	0 to 100 (%) or "no" (ignore)	Setting of the analog input value to be applied when WC (Dc) is output.

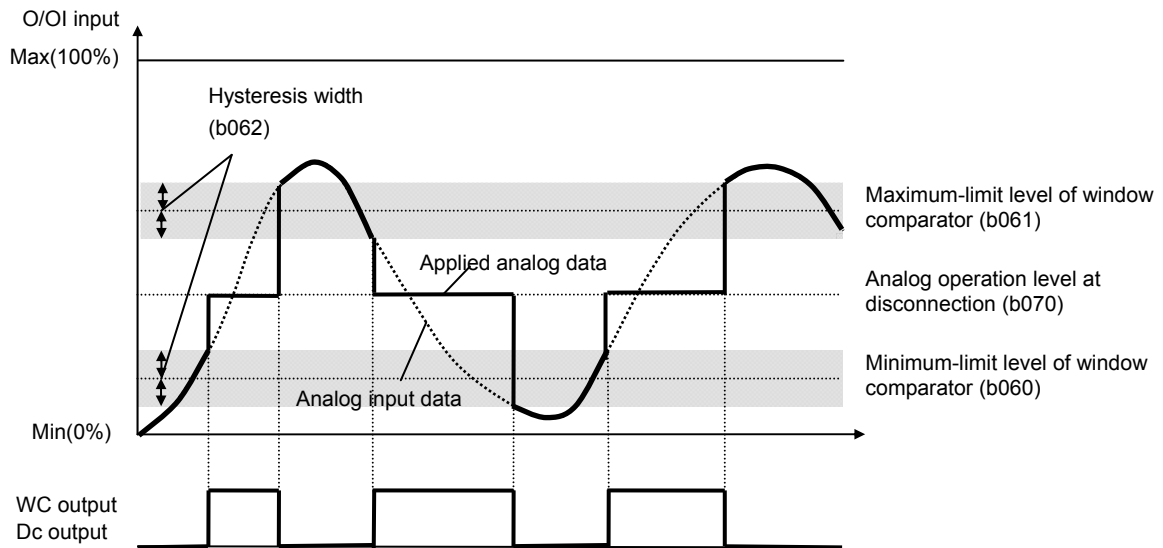

Chapter 7 Explanation of Functions

7.8.22 Frequency command source (FREF)

This function outputs a signal when the (A001 = 02). However, this function is disabled when the second control mode.

The rest of the time (A001 = 02) the signal is turned OFF.

Item	Function code	Data	Description
Terminal [11] functions	C021	58	FREF : Frequency reference
Alarm relay terminal function	C026		

7.8.23 RUN command source (REF)

This function outputs a signal when the (A002 = 02). However, this function is disabled when the second control mode.

The rest of the time (A002 = 02) the signal is turned OFF.

Item	Function code	Data	Description
Terminal [11] functions	C021	59	REF : Run reference
Alarm relay terminal function	C026		

7.8.24 2nd Motor in operation (SETM)

When SET terminal of intelligent input is ON, it output signal.

Item	Function code	Data	Description
Terminal [11] functions	C021	60	SETM : 2 nd motor in operation
Alarm relay terminal function	C026		

7.8.25 Ground fault detection [C155]

When the power is turned on, then select whether to ground fault detection.

Ground fault detection might be detected when the power is turned while the motor is rotating.

Item	Function code	Data	Description
Ground fault detection	C155	00,01	00 : OFF、01 : ON

7.8.26 Out phase loss detection [C157]

This function is to choose whether to perform output phase loss detection.

This function works when the output frequency for not less than 5Hz but not more than 100Hz.

In some cases depending on the state of the output current is low or not detected, this function doesn't work. In addition, this function may be detected when hunting.

Item	Function code	Data	Description
Out phase loss detection	C157	00,01	00 : OFF、01 : ON

7.9 Initializing

7.9.1 Initialization setting

The initialization function allows you to initialize the adjusted settings on the inverter to restore the factory (default) settings. You can also clear the trip history data alone.

The Cumulative operation RUN time / Power on time are not cleared.

Item	Function code	Data	Description
Initialization mode (parameters or trip history)	b084	00	Disabling
		01	Clearing the trip history
		02	Initializing the data
		03	Clearing the trip history and Initializing the data
Initialization target data setting	b094	00	All parameters
		01	All parameters except in/output terminals and communication (Note1)
Restricted Distribution code for initialization (Note1)	b085	00	Mode 0 (Restricted Distribution Code : Oher(Standard))
		01	Mode 1 (Restricted Distribution Code : Europe)
		03	Mode 3 (Restricted Distribution Code : China)
Initialization trigger	b180	00	No action
		01	Initialize

Note1: Refer to the Parameter List of Chapter 13 for the difference between Mode 0(00) in Restricted Distribution (b085) , Mode 2(01), and Mode 3(03).

Note2: The parameters to be related to are as follows.

Data of b094	Function code	Description
Parameters for in/output terminals	C001 to C005	Input terminal [1] to [5] function
	C011 to C015	Input terminal [1] to [5] active state
	C021	Output terminal [11] function
	C026	Reray terminal function
	C031	Output terminal [11] active state
	C036	Reray terminal active state
Parameters for communication	C070	Selection of OPE/Modbus
	C071	Communication speed selection
	C072	Communication node allocation
	C074	Communication parity selection
	C075	Communication stop bit selection
	C076	Communication error mode
	C077	Communication error time
	C078	Communication wait time

To initialize the inverter, follow the steps below.

- (1) Select initialization mode in **b084**.
- (2) If **b084=02** or **03**, select initialization target data in **b094**.
- (3) If **b084=02** or **03**, select country code in **b085**.
- (4) Set **01** in **b180**.
- (5) The following display appears for a few seconds, and initialization is completed with **d001** displayed.

Display during initialization

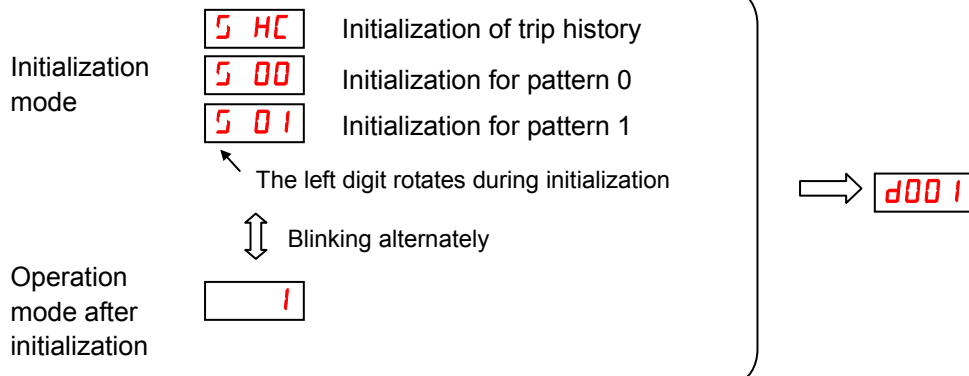

Note3 : Data of b084,b180 are not saved in the memory to avoid unintentional initializing.

Note4 : b085,b094, C081(O/OI input span calibration) is not initialized.

Chapter 8 Communication Functions

This chapter describes the Communication functions. (Modbus-RTU)

8.1	Communication Specification	8 - 1
8.2	Connecting the Inverter to Modbus	8 - 2
8.3	Modbus setting procedure	8 - 3
8.4	Modbus Communication parameter	8 - 4
8.5	Modbus Protocol Reference	8 - 5
8.6	Explanation of function codes	8 - 9
8.7	Re-calculate the internal variable	8 - 18
8.8	Modbus Data Listing	8 - 19

8.1 Communication Specification

NE-S1 Series inverters have built-in RS-485 serial communications, featuring the Modbus RTU protocol. The inverters can connect directly to existing factory networks or work with new networked applications, without any extra interface equipment. The specifications are in the following table.

Item	Specifications	User-selectable
Transmission speed	4800 / 9600 / 19.2k / 38.4k bps	✓
Communication mode	Asynchronous	✗
Character code	Binary	✗
LSB placement	Transmits LSB first	✗
Electrical interface	RS-485 differential transceiver	✗
Data bits	8-bit (Modbus RTU mode)	✗
Parity	None / even / odd	✓
Stop bits	1 or 2 bits	✓
Startup convention	One-way start from host device	✗
Wait time for response	0 to 1000 msec.	✓
Connections	Station address numbers from 1 to 247	✓
Connector	Terminal connector	–
Error check	Overrun, Framing block check code, CRC-16, or horizontal parity	–
Cable length	500m maximum	

The network diagram below shows a series of inverters communicating with a host computer. Each inverter must have a unique address, from 1 to 247, on the network. In a typical application, a host computer or controller is the master and each of the inverter(s) or other devices is a slave.

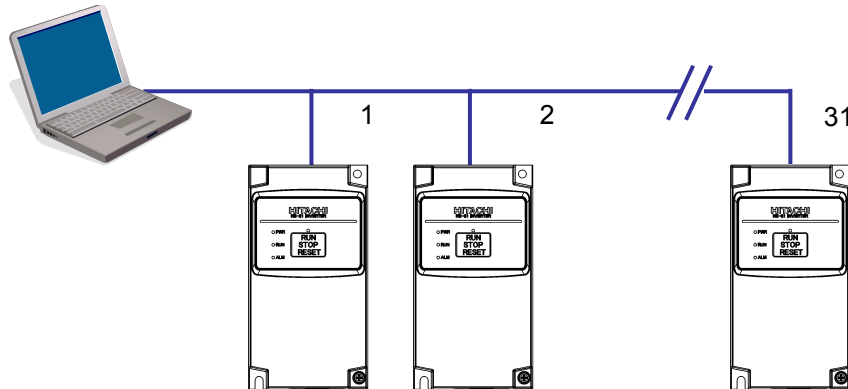

Chapter 8 Communication Functions

8.2 Connecting the Inverter to Modbus

The Modbus communication uses a pin of RJ45 as below.
 The the RJ45 connector is used for the external operator and Modbus communication.

Pin No:	Signal Symbol	Description
1	DC+5V	For Operator. Do not connect.
2	—	For Operator. Do not connect.
3	—	For Operator. Do not connect.
4	SG(GND)	Signal Ground
5	S P	Send Data Positive
6	S N	Send Data Negative
7	(GND)	For Operator. Do not connect.
8	—	Not used. Do not connect.

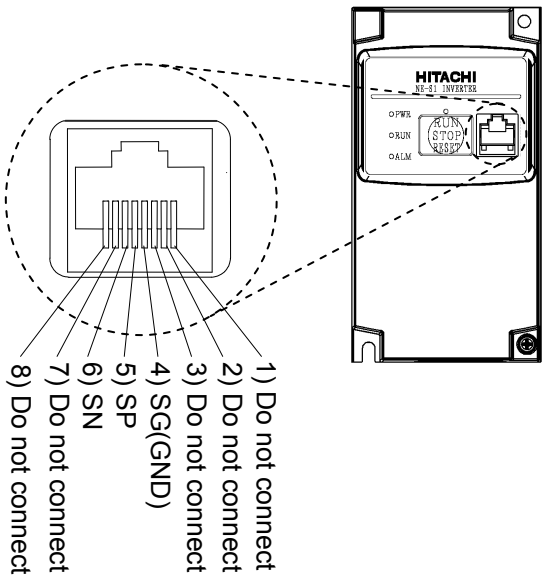

Please connect each inverter like the chart below in parallel.

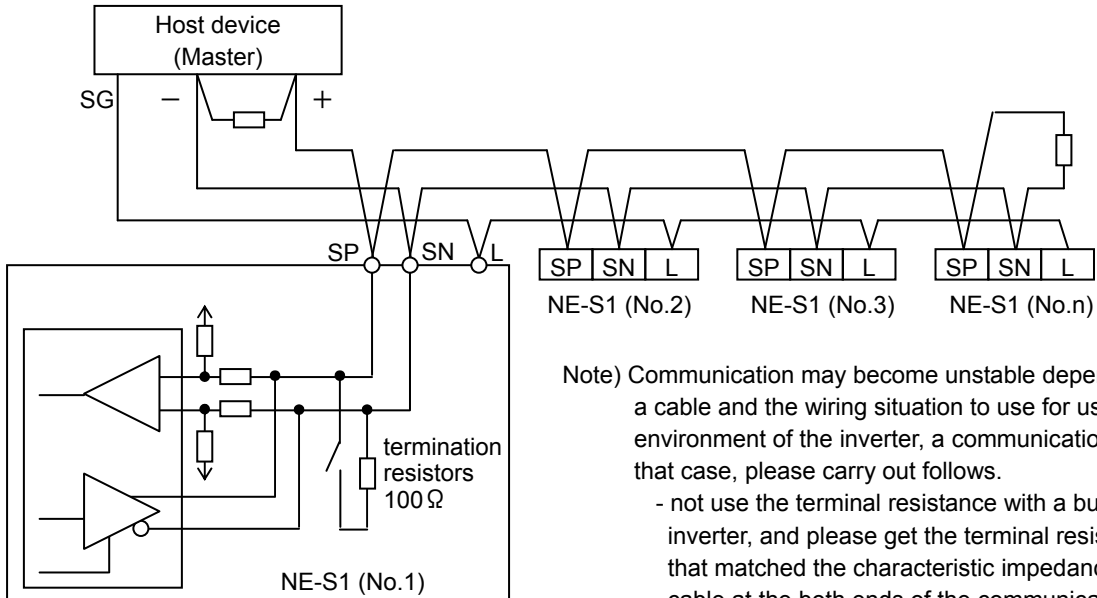

- Note) Communication may become unstable depending on a cable and the wiring situation to use for use environment of the inverter, a communication line. In that case, please carry out follows.
- not use the terminal resistance with a built-in inverter, and please get the terminal resistance that matched the characteristic impedance of the cable at the both ends of the communications cable.(the terminal resistance having built-in to inverter is 100 Ω.)
 - Please connect a signal ground of each inverter to external equipment (master).
 - Please lower a transfer speed.
 - Please insert a repeater.

8.3 Modbus setting procedure

1. Changes from an operator mode to Modbus

- 1) Set a parameter (cf. 8.4) for Modbus communication by the exclusive operator (NES1-OP), remote operator (OPE-S/SR/SBK/SRmini,WOP), or ProDriveNext. (It is necessary to be set the operator side (OFF, right side) in RS485 communication / operator switch (SW5) when use the remote operator (OPE-S/SR/SBK/SRmini,WOP) or ProDriveNext. (default))
- 2) Inverter power OFF and take off the connection cable of the remote operator or ProDriveNext ,etc.
- 3) Remove the front cover.
- 4) Change RS485 communication / operator switch (SW5) to RS485 side (ON, left side).
- 5) When terminal resistance is necessary, Change terminal resistance switch (SW4) to effective (ON, right side).
- 6) Attach the front cover.
- 7) The communications cable connected to bus line of Modbus.
- 8) Inverter power ON and start Modbus communication.

2. Changes from Modbus to an operator mode

- 1) Inverter power OFF and take off a communications cable of Modbus.
- 2) Remove the front cover.
- 3) Change RS485 communication / operator switch (SW5) to operator side (OFF, right side).
- 4) Attach the front cover.
- 5) Connect the connection cable of the remote operator or ProDriveNext ,etc.
- 6) Inverter power ON while pushing the RUN/STOP/RESET key to standard operation panel. (please keep pushing key about 5 seconds.
- 7) After the operator available, change setting of communication choice (C070) to 01(Modbus) → 00(OPE) and inverter power OFF.
- 8) Inverter power ON again. The operator is available.

Note) The exclusive operator (NES1-OP) is available at the time of the Modbus communication use.

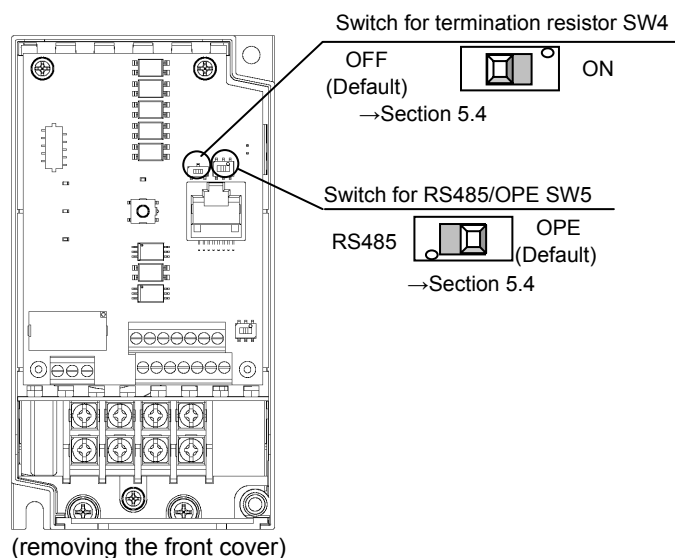

Chapter 8 Communication Functions

8.4 Modbus Communication parameter

Inverter Parameter Setup - The inverter has several settings related to Modbus communications. The table below lists them together. The *Required* column indicates which parameters *must* be set properly to allow communications. You may need to refer to the host computer documentation in order to match some of its settings.

Func. Code	Name	Required	Settings
A001	Frequency source	✓	00...Keypad potentiometer 01...Control terminal 02...Function F001 setting 03...Modbus network input 10 ...Calculate function output
A002	Run command source	✓	01...Control terminal 02...Run key on keypad, or digital operator 03 ... Modbus network input
C070	Selection of OPE/Modbus	✓	00... Operator 01....Modbus-RTU
C071	Communication speed	✓	04...4800 bps 05 9600 bps 06 19.2k bps 07...38.4k bps
C072	Modbus Address	✓	Network address, range is 1 to 247
C074	Communication parity	✓	00...No parity 01...Even parity 02...Odd parity
C075	Communication stop bit	✓	Range is 1 or 2
C076	Communication error select	-	00...Trip (Error code E60) 01...Decelerate to a stop and trip 02...Disable 03...Free run stop (coasting) 04...Decelerate to a stop
C077	Communication error time-out	-	Comm. Watchdog timer period, range is 0.00 to 99.99 sec.
C078	Communication wait time	✓	Time the inverter waits after receiving a message before it transmits. Range is 0. to 1000. ms

Note) When you change any of the parameters above, the inverter power must be rebooted in order to activate new parameters.

8.5 Modbus Protocol Reference

Transmission procedure

The transmission between the external control equipment and the inverter takes the procedure below.

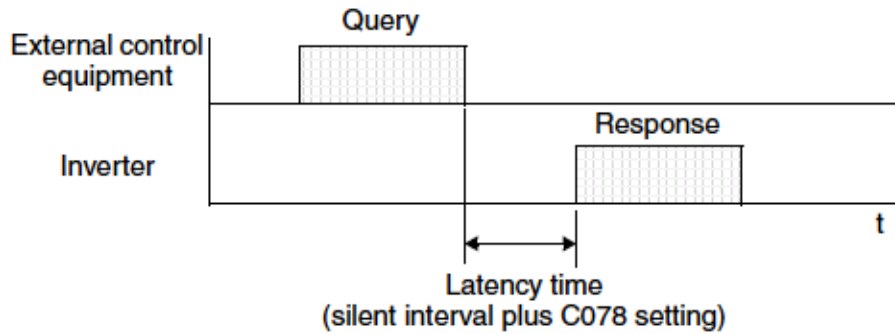

- Query - A frame sent from the external control equipment to the inverter
- Response - A frame returned from inverter to the external control equipment

The inverter returns the response only after the inverter receives a query from the external control equipment and does not output the response positively. Each frame is formatted (with commands) as follows:

Frame Format
Header (silent interval)
Slave address
Function code
Data
Error check
Trailer (silent interval)

Chapter 8 Communication Functions

Message Configuration: Query

Slave address:

- This is a number of 1 to 247 assigned to each inverter (slave). (Only the inverter having the address given as a slave address in the query can receive the query.)
- When slave address "0" is specified, the query can be addressed to all inverters simultaneously. (Broadcasting)
- In broadcasting, you cannot call and loop back data.

Data:

- A function command is set here.
- The data format used in the NE-S1 series is corresponding to the Modbus data format below.

Name of Data	Description
Coil	Binary data that can be referenced and changed (1 bit long)
Holding Register	16-bit data that can be referenced and changed

- The negative data use 2 complements.

Function code:

Specify a function you want to make the inverter execute. Function codes available to the NE-S1 series are listed below.

Function Code	Function	Maximum data size (bytes available per message)	Maximum number of data elements available per message
0 1 h	Read Coil Status	4	32 coils (in bits)
0 3 h	Read Holding Resistor	32	16 registers (in bytes)
0 5 h	Write in Coil	2	1 coil (in bits)
0 6 h	Write in Holding Register	2	1 register (in bytes)
0 8 h	Loopback Test	–	–
0 F h	Write in Coils	4	32 coils (in bits)
1 0 h	Write in Registers	32	16 registers (in bytes)
1 7h	Read/Write Holding Register	32	16 registers (in bytes)

Error check:

Modbus-RTU uses CRC (Cyclic Redundancy Check) for error checking.

- The CRC code is 16-bit data that is generated for 8-bit blocks of arbitrary length.
- The CRC code is generated by a generator polynomial CRC-16 (X¹⁶+ X¹⁵+ X²+ 1).

Header and trailer (silent interval):

Latency is the time between the reception of a query from the master and transmission of a response from the inverter.

- 3.5 characters (24 bits) are always required for latency time. If the latency time shorter than 3.5 characters, the inverter returns no response.
- The actual transmission latency time is the sum of silent interval (3.5 characters long) + C078 (transmission latency time).

Message Configuration: Response

Transmission time required:

- A time period between reception of a query from the master and transmission of a response from the inverter is the sum of the silent interval (3.5 characters long) + C078 (transmission latency time).
- The master must provide a time period of the silent interval (3.5 characters long or longer) before sending another query to an inverter after receiving a response from the inverter.

Normal response:

- When receiving a query that contains a function code of Loopback (08h), the inverter returns a response of the same content of the query.
- When receiving a query that contains a function code of Write in Register or Coil (05h, 06h, 0Fh, or 10h), the inverter directly returns the query as a response.
- When receiving a query that contains a function code of Read Register or Coil (01h or 03h), the inverter returns, as a response, the read data together with the same slave address and function code as those of the query.

Response when an error occurs:

- When finding any error in a query (except for a transmission error), the inverter returns an exception response without executing anything.
- You can check the error by the function code in the response. The function code of the exception response is the sum of the function code of the query and 80h.
- The content of the error is known from the exception code.

Field Configuration
Slave address
Function code
Exception code
CRC-16

Exception Code	Description
0 1 h	The specified function is not supported.
0 2 h	The specified function is not found.
0 3 h	The format of the specified data is not acceptable.
2 1 h	The data to be written in a holding register is outside the inverter.
2 2 h	The specified functions are not available to the inverter. <ul style="list-style-type: none"> • Function to change the content of a register that cannot be changed while the inverter is in service • Function to submit an ENTER command during running (UV) • Function to write in a register during tripping (UV) • Function to change the I/O terminal configuration which is not allowed. • Function to change active state of RS (reset) terminal • Function to write in a register locked by softlock
2 3h	The register (or coil) to be written in is read-only

Chapter 8 Communication Functions

No response occurs:

In the cases below, the inverter ignores a query and returns no response.

- When receiving a broadcasting query
- When detecting a transmission error in reception of a query
- When the slave address set in the query is not equal to the slave address of the inverter
- When a time interval between data elements constituting a message is shorter than 3.5 characters
- When the data length of the query is invalid
- When the reception space is more than 1.5 characters in the frame
- When an error check cord of query is incongruous (CRC error)

Note) Provide a timer in the master and make the master retransmit the same query when no response is made within a preset time period after the preceding query was sent.

8.6 Explanation of function codes

(A) Read Coil Status [01h]

This function reads the status (ON/OFF) of selected coils. An example follows below.

- Read intelligent input terminals [1] to [5] of an inverter having a slave address “8.”
- This example assumes the intelligent input terminals have terminal states listed below.

Item	Data				
Intelligent input terminal	[1]	[2]	[3]	[4]	[5]
Coil number	7	8	9	10	11
Coil Status	ON	OFF	ON	OFF	OFF

Query:

No.	Field Name	Example (Hex)
1	Slave address *1	08
2	Function code	01
3	Coil start address *4 (high order)	00
4	Coil start address *4 (low order)	06
5	Number of coils (high order *2)	00
6	Number of coils (low order *2)	05
7	CRC-16 (high order)	1C
8	CRC-16 (low order)	91

Response:

No.	Field Name	Example (Hex)
1	Slave address	08
2	Function code	01
3	Data size (in bytes)	01
4	Coil data *3	05
5	CRC-16 (high order)	92
6	CRC-16 (low order)	17

Note 1: Broadcasting is disabled.

Note 2: When 0 or more than 31 is specified as a number of coils, error code “03h” is returned.

Note 3: Data is transferred by the specified number of data bytes (data size).

Note 4: The PDU Coils are addressed starting at zero. Therefore coils numbered 1-86 are addressed as 0-85. Coil address value (transmitted on Modbus line) is 1 less than the Coil Number.

- The data set in the response shows terminal state of coils 0007h~000Dh.
- Data “05h = 0000101b” indicates the following assuming coil 7 is the LSB.

Item	Data							
Coil Number	14	13	12	11	10	9	8	7
Coil Status	OFF	OFF	OFF	OFF	OFF	ON	OFF	ON

- When a read coil is outside the defined coils, the final coil data to be transmitted contains “0” as the status of the coil outside the range.
- When the Read Coil Status command cannot be executed normally, see the exception response.

Chapter 8 Communication Functions

(B) Read Holding Register [03h]

This function reads the contents of the specified number of consecutive holding registers (of specified register addresses). An example follows below.

- Reading Trip monitor 1 factor and trip frequency, current, and voltage from an inverter having a slave address "1"
- This example assumes the previous six trip factors are as follows:

NE-S1 Command	D081 (factor)	D081 (status)	D081 (frequency)	D081 (output current)	D081 (DC-bus Voltage)
Register Number	0012h	0013h	0014h	0016h	0017h
Trip factor	Over-Current (E03)	04h	9.9Hz	3.0A	284V

Query:

No.	Field Name	Example (Hex)
1	Slave address *1	01
2	Function code	03
3	Register start address *3 (high order)	00
4	Register start address *3 (low order)	11
5	Number of holding registers (high order)	00
6	Number of holding registers (low order)	06
7	CRC-16 (high order)	95
8	CRC-16 (low order)	CD

Response:

No.	Field Name	Example (Hex)
1	Slave address	01
2	Function code	03
3	Data size (in bytes) *2	0C
4	Register data 1 (high order)	00
5	Register data 1 (high order)	03
6	Register data 2 (high order)	00
7	Register data 2 (low order)	04
8	Register data 3 (high order)	00
9	Register data 3 (low order)	00
10	Register data 4 (high order)	00
11	Register data 4 (low order)	63
12	Register data 5 (high order)	00
13	Register data 5 (low order)	1E
14	Register data 6 (high order)	01
15	Register data 6 (low order)	1C
16	CRC-16 (high order)	0A
17	CRC-16 (low order)	A3

Note 1: Broadcasting is disabled.

Note 2: Data is transferred by the specified number of data bytes (data size). In this case, 12 bytes are used to return the content of six holding registers.

Note 3: The PDU Register Number are addressed starting at zero. Therefore register numbered "0012h" are addressed as "0011h". Register address value (transmitted on Modbus line) is 1 less than the Register Number.

The data set in the response is as follows:

Response Buffer	4-5		6-7		8-9	
Register Number	12+0 (high order)	12+0 (low order)	12+1 (high order)	12+1 (low order)	12+2 (high order)	12+2 (low order)
Register Data	0003h		04h		0000h	
Trip data	Trip factor (E03)		Status		Frequency (9.9Hz)	
Response Buffer	10-11		12-13		14-15	
Register Number	12+3 (high order)	12+3 (low order)	12+4 (high order)	12+4 (low order)	12+5 (high order)	12+5 (low order)
Register Data	0063h		001Eh		011Ch	
Trip data	Frequency (9.9Hz)		Output current (3.0A)		DC-bus voltage (284V)	

When the Read Holding Register command cannot be executed normally, refer to the exception response.

(C) Write in Coil [05h]

This function writes data in a single coil. Coil status changes are as follows:

Data	Coil Status	
	OFF to ON	ON to OFF
Change data (high order)	FFh	00h
Change data (low order)	00h	00h

An example follows (note that to command the inverter, set A002=03):

- Sending a RUN command to an inverter having slave address “8”
- This example writes in coil number “1.”

Query:

No.	Field Name	Example (Hex)
1	Slave address *1	08
2	Function code	05
3	Coil start address *2 (high order)	00
4	Coil start address *2 (low order)	00
5	Change data (high order)	FF
6	Change data (low order)	00
7	CRC-16 (high order)	8C
8	CRC-16 (low order)	A3

Response:

No.	Field Name	Example (Hex)
1	Slave address	08
2	Function code	05
3	Coil start address *2 (high order)	00
4	Coil start address *2 (low order)	00
5	Change data (high order)	FF
6	Change data (low order)	00
7	CRC-16 (high order)	8C
8	CRC-16 (low order)	A3

Note 1: No response is made for a broadcasting query.

Note 2: The PDU Coils are addressed starting at zero. Therefore coils numbered 1-86 are addressed as 0-85. Coil address value (transmitted on Modbus line) is 1 less than the Coil Number.

When writing in a selected coil fails, see the exception response.

Chapter 8 Communication Functions

(D) Write in Holding Register [06h]

This function writes data in a specified holding register. An example follows:

- Write “50Hz” as the first Multi-speed 0 (A020) in an inverter having slave address “5.”
- This example uses change data “500(1F4h)” to set “50Hz” as the data resolution of the register “1019h” holding the first Multi-speed 0 (A020) is 0.1Hz

Query:

No.	Field Name	Example (Hex)
1	Slave address *1	05
2	Function code	06
3	Register start address *2 (high order)	12
4	Register start address *2 (low order)	16
5	Change data (high order)	01
6	Change data (low order)	F4
7	CRC-16 (high order)	6C
8	CRC-16 (low order)	E5

Response:

No.	Field Name	Example (Hex)
1	Slave address	05
2	Function code	06
3	Register start address *2 (high order)	12
4	Register start address *2 (low order)	16
5	Change data (high order)	01
6	Change data (low order)	F4
7	CRC-16 (high order)	6C
8	CRC-16 (low order)	E5

Note 1: No response is made for a broadcasting query.

Note 2: The PDU Register Number are addressed starting at zero. Therefore register numbered “1217h” are addressed as “1216h”. Register address value (transmitted on Modbus line) is 1 less than the Register Number.

When writing in a selected holding register fails, see the exception response.

(E) Loopback Test [08h]

This function checks a master-slave transmission using any test data. An example follows:

- Send test data to an inverter having slave address "1" and receiving the test data from the inverter (as a loopback test).

Query:

No.	Field Name	Example (Hex)
1	Slave address *1	01
2	Function code	08
3	Test subcode (high order)	00
4	Test subcode (low order)	00
5	Data (high order)	Any
6	Data (low order)	Any
7	CRC-16 (high order)	CRC
8	CRC-16 (low order)	CRC

Response:

No.	Field Name	Example (Hex)
1	Slave address *1	01
2	Function code	08
3	Test subcode (high order)	00
4	Test subcode (low order)	00
5	Data (high order)	Any
6	Data (low order)	Any
7	CRC-16 (high order)	CRC
8	CRC-16 (low order)	CRC

Note 1: Broadcasting is disabled.

When test subcode is for echo (00h, 00h) only and not available to the other commands.

Chapter 8 Communication Functions

(F) Write in Coils [0Fh]

This function writes data in consecutive coils. An example follows:

- Change the state of intelligent input terminal [1] to [5] of an inverter having a slave address "8."
- This example assumes the intelligent input terminals have terminal states listed below.

Item	Data				
Intelligent input terminal	[1]	[2]	[3]	[4]	[5]
Coil Number	7	8	9	10	11
Terminal status	ON	ON	ON	OFF	ON

Query:

No.	Field Name	Example (Hex)
1	Slave address *1	08
2	Function code	0F
3	Coil start address *3 (high order)	00
4	Coil start address *3 (low order)	06
5	Number of coils (high order)	00
6	Number of coils (low order)	05
7	Byte number *2	02
8	Change data (high order)	17
9	Change data (low order)	00
10	CRC-16 (high order)	83
11	CRC-16 (low order)	EA

Response:

No.	Field Name	Example (Hex)
1	Slave address	08
2	Function code	0F
3	Coil start address *3 (high order)	00
4	Coil start address *3 (low order)	06
5	Number of coils (high order)	00
6	Number of coils (low order)	05
7	CRC-16 (high order)	75
8	CRC-16 (low order)	50

Note 1: Broadcasting is disabled.

Note 2: The change data is a set of high-order data and low-order data. So when the size (in bytes) of data to be changed is an odd start coil number ("7"), add "1" to the data size (in bytes) to make it an even number.

Note 3: The PDU Coils are addressed starting at zero. Therefore coils numbered 1-86 are addressed as 0-85. Coil address value (transmitted on Modbus line) is 1 less than the Coil Number.

Note 4: Intelligent input monitor (d005) cannot monitor the terminal information by communication.

(G) Write in Holding Registers [10h]

This function writes data in consecutive holding registers. An example follows:

- Write “3000 seconds” as the first acceleration time 1 (F002) in an inverter having a slave address “8.”
- This example uses change data “300000(493E0h)” to set “3000 seconds” as the data resolution of the registers “1103h” and “1104h” holding the first acceleration time 1 (F002) is 0.01 second.

Query:

No.	Field Name	Example (Hex)
1	Slave address *1	08
2	Function code	10
3	Start address *3 (high order)	11
4	Start address *3 (low order)	02
5	Number of holding registers (high order)	00
6	Number of holding registers (low order)	02
7	Byte number *2	04
8	Change data 1 (high order)	00
9	Change data 1 (low order)	04
10	Change data 2 (high order)	93
11	Change data 2 (low order)	E0
12	CRC-16 (high order)	B0
13	CRC-16 (low order)	03

Response:

No.	Field Name	Example (Hex)
1	Slave address	08
2	Function code	10
3	Start address *3 (high order)	11
4	Start address *3 (low order)	02
5	Number of holding registers (high order)	00
6	Number of holding registers (low order)	02
7	CRC-16 (high order)	E5
8	CRC-16 (low order)	AD

Note 1: Broadcasting is disabled.

Note 2: This is not the number of holding registers. Specify the number of bytes of data to be changed.

Note 3: The PDU Register Number are addressed starting at zero. Therefore register numbered “1103h” are addressed as “1102h”. Register address value (transmitted on Modbus line) is 1 less than the Register Number.

When writing in selected holding registers fails, see the exception response.

Chapter 8 Communication Functions

(H) Write in Holding Registers [17h]

This function is to read and write data in consecutive holding registers. An example follows:

- Write “50.0Hz” as the set frequency (F001) in an inverter having a slave address “1” and then to read out the output frequency (d001).

Query:

No.	Field Name	Example (Hex)
1	Slave address *1	01
2	Function code	17
3	Start address to read *3 (high order)	10
4	Start address to read *3 (low order)	00
5	Number of holding registers to read (high order)	00
6	Number of holding registers to read (low order)	02
7	Start address to write *3 (high order)	00
8	Start address to write *3 (low order)	00
9	Number of holding registers to write (high order)	00
10	Number of holding registers to write (low order)	02
11	Byte number to write*2	04
12	Change data 1 (high order)	00
13	Change data 1 (low order)	00
14	Change data 2 (high order)	13
15	Change data 2 (low order)	88
16	CRC-16 (high order)	F4
17	CRC-16 (low order)	86

Response:

No.	Field Name	Example (Hex)
1	Slave address	01
2	Function code	17
3	Byte number n	04
4	Register Data 1 (high order)	00
5	Register Data 1 (low order)	00
6	Register Data 2 (high order)	13
7	Register Data 2 (low order)	88
8	CRC-16 (high order)	F4
9	CRC-16 (low order)	71

Note 1: Register address value (transmitted on Modbus line) is 1 less than the Register Number.

When writing in selected holding registers fails, see the exception response.

(I) Exception Response

When sending a query (excluding a broadcasting query) to an inverter, the master always requests a response from the inverter. Usually, the inverter returns a response according to the query. However, when finding an error in the query, the inverter returns an exception response. The exception response consists of the fields shown below.

Field Configuration
Slave address
Function code
Exception code
CRC-16

The content of each field is explained below. The function code of the exception response is the sum of the function code of the query and 80h. The exception code indicates the factor of the exception response.

Function Code	
Query	Exception Response
0 1 h	8 1 h
0 3 h	8 3 h
0 5 h	8 5 h
0 6 h	8 6 h
0 F h	8 F h
1 0 h	9 0 h
1 7 h	9 7 h

Exception Code	
Code	Description
0 1 h	The specified function is not supported.
0 2 h	The specified function is not found.
0 3 h	The format of the specified data is not acceptable.
2 1 h	The data to be written in a holding register is outside the inverter.
2 2 h	The specified functions are not available to the inverter. <ul style="list-style-type: none"> • Function to change the content of a register that cannot be changed while the inverter is in service • Function to submit an ENTER command during running (UV) • Function to write in a register during tripping (UV) • Function to write in a read-only register (or coil) • to write in a register during softlock • to change the input/output terminal which could not be changed • to change NO->NC of Reset terminal
2 3 h	To write a register/coil for READ ONLY

Chapter 8 Communication Functions

8.7 Re-calculate the internal variable

There are necessary data of the recomputation.
In this case, use the ENTER command.

(A) ENTER Command

When recalculate the internal value, Set 0000h to the register(0900h) by the Write in Holding Register command [06h].

Value	Description
0000h	recalculate the internal value

List of parameters needing the recalculation of the internal variable

code	Function name	code	Function name
A003/A203	Base frequency	H003/H203	Motor capacity
A004/A204	Maximum frequency	H004/H204	Motor poles setting
A044/A244	V/f characteristic curve		
A082/A282	AVR voltage select		
b112	Free V/F setting, freq.7		

Note) NE-S1 series does not have a data store command/register because the data of all parameters store at the time of power supply OFF. Therefore, it is necessary to put back data before power supply OFF when need to use the data before the change in next power supply injection.

8.8 Modbus Data Listing

(A) Modbus Coil List

The following tables list the primary coils for the inverter interface to the network. The table legend is given below.

- **Coil No.** - The network *register address offset* for the coil. The coil data is a single bit (binary) value.
- **Item** - The functional name of the coil
- **R/W** - The read-only (R) or read-write (R/W) access permitted to the inverter data
- **Setting** - The meaning of each of the states of the coils

Coil No.	Item	R/W	Setting
0000h	unused	-	(Inaccessible)
0001h	Operation command	R/W	1: Run, 0: Stop (valid when A002/A202 = 03)
0002h	Rotation direction command	R/W	1: Reverse rotation, 0: Forward rotation (valid when A002/A202 = 03)
0003h	External trip (EXT)	R/W	1: Trip
0004h	Trip reset (RS)	R/W	1: Reset
0005h	(Reserved)	-	-
0006h	(Reserved)	-	-
0007h	Intelligent input terminal [1]	R/W	1: ON, 0: OFF (*1)
0008h	Intelligent input terminal [2]	R/W	1: ON, 0: OFF (*1)
0009h	Intelligent input terminal [3]	R/W	1: ON, 0: OFF (*1)
000Ah	Intelligent input terminal [4]	R/W	1: ON, 0: OFF (*1)
000Bh	Intelligent input terminal [5]	R/W	1: ON, 0: OFF (*1)
000Ch to 000Eh	(Reserved)	-	-
000Fh	Operation status	R	1: Run, 0: Stop (interlocked to "d003")
0010h	Rotation direction	R	1: Reverse rotation, 0: Forward rotation (interlocked to "d003")
0011h	Inverter ready (IRDY)	R	1: Ready, 0: Not ready (Same as Coil No.0045h)
0012h	(Reserved)	-	-
0013h	RUN (running)	R	1: ON, 0: OFF
0014h	FA1 (constant-speed reached)	R	1: ON, 0: OFF
0015h	FA2 (set frequency overreached)	R	1: ON, 0: OFF
0016h	OL (overload advance notice (1))	R	1: ON, 0: OFF
0017h	OD (output deviation for PID control)	R	1: ON, 0: OFF
0018h	AL (alarm signal)	R	1: ON, 0: OFF
0019h	FA3 (set frequency reached)	R	1: ON, 0: OFF
001Ah	(Reserved)	-	-
001Bh	(Reserved)	-	-
001Ch	UV (undervoltage)	R	1: ON, 0: OFF
001Dh	(Reserved)	-	-
001Eh	RNT (operation time over)	R	1: ON, 0: OFF
001Fh	ONT (plug-in time over)	R	1: ON, 0: OFF
0020h	THM (thermal alarm signal)	R	1: ON, 0: OFF
0021h to 0027h	(Reserved)	-	-
0028h	ZS (0 Hz detection signal)	R	1: ON, 0: OFF
0029h to 002Dh	(Reserved)	-	-

Chapter 8 Communication Functions

Coil No.	Item	R/W	Setting
002Eh	Odc: Analog O disconnection detection	-	1: ON, 0: OFF
002Fh to 0031h	(Reserved)	-	-
0032h	FBV (PID feedback comparison)	R	1: ON, 0: OFF
0033h	NDc (communication train disconnection)	R	1: ON, 0: OFF
0034h	LOG1 (logical operation result 1)	R	1: ON, 0: OFF
0035h to 003Bh	(Reserved)	-	-
003Ch	FR (starting contact signal)	R	1: ON, 0: OFF
003Dh	OHF (heat sink overheat warning)	R	1: ON, 0: OFF
003Eh	LOC (low-current indication signal)	R	1: ON, 0: OFF
003Fh to 0044h	(Reserved)	-	-
0045h	IRDY (inverter ready)	R	1: ON, 0: OFF (Same as Coil No.0011h)
0046h	FWR (forward rotation)	R	1: ON, 0: OFF
0047h	RVR (reverse rotation)	R	1: ON, 0: OFF
0048h	MJA (major failure)	R	1: ON, 0: OFF
0049h	(Reserved)	-	-
004Ah	CRC error	R	1: Error detected, 0: No error (*3)
004Bh	Overrun	R	1: Error detected, 0: No error (*3)
004Ch	Framing error	R	1: Error detected, 0: No error (*3)
004Dh	Parity error	R	1: Error detected, 0: No error (*3)
004Eh	(Reserved)	-	-
004Fh	(Reserved)	-	-
0050h	WCO (window comparator O)	R	1: ON, 0: OFF
0051h to 0053h	(Reserved)	-	-
0054h	FREF (FQ command source)	R	1: Operator, 0: Others
0055h	REF (RUN command source)	R	1: Operator, 0: Others
0056h	SETM (2nd motor selected)	R	1: 2nd motor selected, 0: 1st motor selected
0057h	(Reserved)	-	-
0058h	(Reserved)	-	-
0059h-	unused	R	inaccessible

- *1 The input terminal function can do ON/OFF by Modbus communication. If either the coil of the input terminal or the signal of the control circuit is ON, the inverter recognize it to be ON. But ON by the communication does not display on the input terminal monitor (d005), because (d005) is a monitor for the signal of the control circuit only.
- *2 The writable coil is cleared (0(OFF)) by the reset input. When you do not want to clear, please set C102(reset choice) = 02. (but cleared by the reset at the time of the trip.)
- *3 Communication error data is retained until an error reset command is input. (In the case of (C102(reset choice) = 02), error is cleared at the time of a trip only.)
(Reset: terminal reset function, reset of coil (coil No.0004h))

(B) Modbus Holding Registers

The following tables list the holding registers for the inverter interface to the network. The table legend is given below.

- **Function name** - The standard functional name of the parameter or function for the inverter
- **Function code** - The inverter's reference code for the parameter or function (same as inverter keypad display)
- **R/W** - The read-only(R) or read-write access(R/W) permitted to the data in the inverter
- **Monitoring and setting items** - How the parameter or setting works (same as Chapter 3 description).
- **Register No.** - The network *register address offset* for the value. Some values have a high-byte and low-byte address.
- **Resolution** - This is the quantity represented by the LSB of the network value, in engineering units. When the network data range is greater than the inverter's internal data range, this 1-bit resolution will be fractional.

Note): The network values are binary integers. Since these values cannot have an embedded decimal point, for many parameters it represents the actual value (in engineering units) multiplied by a factor of 10 or 100. Network communications must use the listed range for network data. The inverter automatically divides received values by the appropriate factor in order to establish the decimal point for internal use. Likewise, the network host computer must apply the same factor when it needs to work in engineering units. However, when sending data to the inverter, the network host computer must scale values to the integer range listed for network communications

(1) Registers (frequency, status, trip monitor)

Register No.	Function name	Function code	R/W	Monitoring and setting items	Data resolution
0000h	unused	-	-	Inaccessible	
0001h	Frequency source	F001 (high)	R/W	0 to 40000 (valid when A001/A201 = 03)	0.01 [Hz]
0002h		F001 (low)	R/W		
0003h	Inverter status A	-	R	0: Initial status 2: Stopping 3: Running 4: Free-run stop 5: Jogging 6: DC braking 7: Retrying 8: Tripping 9: Undervoltage (UV)	-
0004h	Inverter status B	-	R	0: Stopping, 1: Running, 2: Tripping	-
0005h	Inverter status C	-	R	0: --- 1: Stopping 2: Decelerating 3: Constant-speed operation 4: Accelerating 5: Forward rotation 6: Reverse rotation 7: Switching from fwd. to rev. rotation, 8: Switching from rev. to fwd. rotation, 9: Starting fwd. 10: Starting rev.	-
0006h	PID feedback	-	R/W	0 to 10000	0.01 [%]
0007h to 0010h	(Reserved)	-	R	-	-

Chapter 8 Communication Functions

Register No.	Function name	Function code	R/W	Monitoring and setting items	Data resolution		
0011h	Trip Counter	d080	R	0 to 65530	1 [time]		
0012h	Trip info. 1 (factor)	d081	R	See the list of inverter trip factors below	-		
0013h	Trip info. 1 (inverter status)			See the list of inverter trip factors below	-		
0014h	Trip info. 1 (frequency) (high)			0 to 40000	0.01[Hz]		
0015h	Trip info. 1 (frequency) (low)						
0016h	Trip info. 1 (current)			Output current at tripping	0.01[A]		
0017h	Trip info. 1 (voltage)			DC input voltage at tripping	0.1[V]		
0018h	Trip info. 1 (running time) (high)			Cumulative running time at tripping	1[h]		
0019h	Trip info. 1 (running time) (low)						
001Ah	Trip info. 1 (power-on time) (high)			Cumulative power-on time at tripping	1[h]		
001Bh	Trip info. 1 (power-on time) (low)						
001Ch	Trip info. 2 (factor)			d082	R	See the list of inverter trip factors below	-
001Dh	Trip info. 2 (inverter status)					See the list of inverter trip factors below	-
001Eh	Trip info. 2 (frequency) (high)	0 to 40000	0.01[Hz]				
001Fh	Trip info. 2 (frequency) (low)						
0020h	Trip info. 2 (current)	Output current at tripping	0.01[A]				
0021h	Trip info. 2 (voltage)	DC input voltage at tripping	0.1[V]				
0022h	Trip info. 2 (running time) (high)	Cumulative running time at tripping	1[h]				
0023h	Trip info. 2 (running time) (low)						
0024h	Trip info. 2 (power-on time) (high)	Cumulative power-on time at tripping	1[h]				
0025h	Trip info. 2 (power-on time) (low)						
0026h	Trip info. 3 (factor)	d083	R			See the list of inverter trip factors below	-
0027h	Trip info. 3 (inverter status)					See the list of inverter trip factors below	-
0028h	Trip info. 3 (frequency) (high)			0 to 40000	0.01[Hz]		
0029h	Trip info. 3 (frequency) (low)						
002Ah	Trip info. 3 (current)			Output current at tripping	0.01[A]		
002Bh	Trip info. 3 (voltage)			DC input voltage at tripping	0.1[V]		
002Ch	Trip info. 3 (running time) (high)			Cumulative running time at tripping	1[h]		
002Dh	Trip info. 3 (running time) (low)						
002Eh	Trip info. 3 (power-on time) (high)			Cumulative power-on time at tripping	1[h]		
002Fh	Trip info. 3 (power-on time) (low)						
0030h	Trip info. 4 (factor)			d084	R	See the list of inverter trip factors below	-
0031h	Trip info. 4 (inverter status)					See the list of inverter trip factors below	-
0032h	Trip info. 4 (frequency) (high)	0 to 40000	0.01[Hz]				
0033h	Trip info. 4 (frequency) (low)						
0034h	Trip info. 4 (current)	Output current at tripping	0.01[A]				
0035h	Trip info. 4 (voltage)	DC input voltage at tripping	0.1[V]				
0036h	Trip info. 4 (running time) (high)	Cumulative running time at tripping	1[h]				
0037h	Trip info. 4 (running time) (low)						
0038h	Trip info. 4 (power-on time) (high)	Cumulative power-on time at tripping	1[h]				
0039h	Trip info. 4 (power-on time) (low)						
003Ah	Trip info. 5 (factor)	d085	R			See the list of inverter trip factors below	-
003Bh	Trip info. 5 (inverter status)					See the list of inverter trip factors below	-
003Ch	Trip info. 5 (frequency) (high)			0 to 40000	0.01[Hz]		
003Dh	Trip info. 5 (frequency) (low)						
003Eh	Trip info. 5 (current)			Output current at tripping	0.01[A]		
003Fh	Trip info. 5 (voltage)			DC input voltage at tripping	0.1[V]		
0040h	Trip info. 5 (running time) (high)			Cumulative running time at tripping	1[h]		
0041h	Trip info. 5 (running time) (low)						
0042h	Trip info. 5 (power-on time) (high)			Cumulative power-on time at tripping	1[h]		
0043h	Trip info. 5 (power-on time) (low)						
0044h	Trip info. 6 (factor)			d086	R	See the list of inverter trip factors below	-
0045h	Trip info. 6 (inverter status)					See the list of inverter trip factors below	-
0046h	Trip info. 6 (frequency) (high)	0 to 40000	0.01[Hz]				
0047h	Trip info. 6 (frequency) (low)						
0048h	Trip info. 6 (current)	Output current at tripping	0.01[A]				
0049h	Trip info. 6 (voltage)	DC input voltage at tripping	0.1[V]				
004Ah	Trip info. 6 (running time) (high)	Cumulative running time at tripping	1[h]				
004Bh	Trip info. 6 (running time) (low)						
004Ch	Trip info. 6 (power-on time) (high)	Cumulative power-on time at tripping	1[h]				
004Dh	Trip info. 6 (power-on time) (low)						
004Eh	Programming error monitoring	d090	R			See the list of warning data	-
004Fh to 08EFh	(reserved)	-	-			-	-
0900h	recalculate the internal value	-	W	0: recalculate	-		
0901h to 1000h	(reserved)	-	-	Inaccessible	-		

i) List of inverter trip factors

Upper part of trip factor code (indicating the factor)		Lower part of trip factor code (indicating the inverter status)	
Name	Code	Name	Code
No trip factor	0	Resetting	0
Over-current event while at constant speed	1	Stopping	1
Over-current event during deceleration	2	Decelerating	2
Over-current event during acceleration	3	Constant-speed operation	3
Over-current event during other conditions	4	Accelerating	4
Overload protection	5	Operating at zero frequency	5
Overvoltage protection	7	Starting	6
Memory error	8	DC braking	7
Undervoltage protection	9	Overload restricted	8
Current detection error	10		
CPU error	11		
External trip	12		
USP error	13		
Ground-fault protection	14		
Input overvoltage protection	15		
Inverter thermal trip	21		
CPU error	22		
Driver error	30		
Output phase loss protection	34		
Low-speed overload protection	38		
Operator connection	40		
Modbus communication error	41		

Chapter 8 Communication Functions

ii) List of warning data

Modbus data	Operator display	Condition		
1	H 001	Frequency upper limit setting (A061)	>	Maximum frequency setting (A004)
2	H 002	Frequency lower limit setting (A062)	>	Maximum frequency setting (A004)
3	H 005	Output frequency setting (F001), multispeed 0 (A020) (note 1)	>	Maximum frequency setting (A004)
10	H 015	Output frequency setting (F001), multispeed 0 (A020) (note 1)	>	Frequency upper limit setting (A061)
17	H 025	Frequency lower limit setting (A062)	>	Output frequency setting (F001), multispeed 0 (A020) (note 1)
23	H 031	Start frequency adjustment (b082)	>	Frequency upper limit setting (A061)
25	H 032	Start frequency adjustment (b082)	>	Frequency lower limit setting (A062)
27	H 035	Start frequency adjustment (b082)	>	Output frequency setting (F001), multispeed 0 (A020) (note 1)
30	H 037	Start frequency adjustment (b082)	>	Jog frequency setting (A038)
31	H 085	Output frequency setting (F001), multispeed 0 (A020) (note 1)	=	Jump (center) frequency settings 1/2/3 ± " Jump (hysteresis) frequency width settings 1/2/3" A063 ± A064, A065 ± A066, A067 ± A068
33	H 086	Multispeed 1 to 7 settings (A021 to A027)	=	
34	H 091	Free-setting V/f frequency (7) (b112)	<	Frequency upper limit setting (A061)
36	H 092	Free-setting V/f frequency (7) (b112)	<	Frequency lower limit setting (A062)
38	H 095	Free-setting V/f frequency (7) (b112)	<	Output frequency setting (F001), multispeed 0 (A020) (note 1)
5	H 201	Frequency upper limit setting (A261)	>	Maximum frequency setting (A204)
6	H 202	Frequency lower limit setting (A262)	>	Maximum frequency setting (A204)
7	H 205	Output frequency setting (F001), multispeed 0 (A220) (note 1)	>	Maximum frequency setting (A204)
14	H 215	Output frequency setting (F001), multispeed 0 (A220) (note 1)	>	Frequency upper limit setting (A261)
21	H 225	Frequency lower limit setting (A262)	>	Output frequency setting (F001), multispeed 0 (A220) (note 1)
24	H 231	Start frequency adjustment (b082)	>	Frequency upper limit setting (A261)
26	H 232	Start frequency adjustment (b082)	>	Frequency lower limit setting (A262)
28	H 235	Start frequency adjustment (b082)	>	Output frequency setting (F001), multispeed 0 (A220) (note 1)
32	H 285	Output frequency setting (F001), multispeed 0 (A220) (note 1)	=	Jump (center) frequency settings 1/2/3 ± " Jump (hysteresis) frequency width settings 1/2/3" A063 ± A064, A065 ± A066, A067 ± A068
35	H 291	Free-setting V/f frequency (7) (b112)	<	
37	H 292	Free-setting V/f frequency (7) (b112)	<	Frequency lower limit setting (A262)
39	H 295	Free-setting V/f frequency (7) (b112)	<	Output frequency setting (F001), multispeed 0 (A220) (note 1)

Note) The warning data of the Modbus communication do not accord with the warning cord of the operator.

(2) Registers (monitoring group d)

Register No.	Function name	Function code	R/W	Monitoring and setting items	Data resolution
1001h	Output frequency monitor	d001 (high)	R	0 to 40000	0.01 [Hz]
1002h		d001 (low)			
1003h	Output current monitor	d002	R	0 to 65530	0.01 [A]
1004h	Rotation direction monitoring	d003	R	0: Stopping, 1: Forward rotation, 2: Reverse rotation	0.1 [Hz]
1005h	Process variable (PV), PID feedback monitoring	d004 (high)	R	0 to 999900	0.1
1006h		d004 (low)			
1007h	Intelligent input terminal status	d005	R	2^0: Terminal 1 to 2^4: Terminal 5	1 bit
1008h	Intelligent output terminal status	d006	R	2^0: Terminal 11 to 2^1: Relay Terminal	1 bit
1009h	Scaled output frequency monitor	d007 (high)	R	0 to 399960	0.01
100Ah		d007 (low)			
100Bh to 1010h	(Reserved)	-	-	Inaccessible	-
1011h	Output voltage monitor	d013	R	0 to 6000	0.1 [V]
1012h	Power monitor	d014	R	0 to 1000	0.1 [kW]
1013h	Watt-hour monitor	d015 (high)	R	0 to 9999000	0.1
1014h		d015 (low)			
1015h	Elapsed RUN time monitor	d016 (high)	R	0 to 999900	1 [h]
1016h		d016 (low)			
1017h	Elapsed power-on time monitor	d017 (high)	R	0 to 999900	1 [h]
1018h		d017 (low)			
1019h	Heat sink temperature monitor	d018	R	-200 to 1500	0.1 [°c]
101Ah to 1025h	(Reserved)	-	-	Inaccessible	-
1026h	DC voltage monitoring (across P and N)	d102	R	0 to 10000	0.1 [V]
1027h	(Reserved)	-	-	Inaccessible	-
1028h	Electronic thermal overload monitoring	d104	R	0 to 1000	0.1 [%]
1029h to 1057h	(Reserved)	-	-	Inaccessible	-
1058h to 1102h	unused	-	-	Inaccessible	-

(3) Registers (group F)

Register No.	Function name	Function code	R/W	Monitoring and setting items	Data resolution
1103h	Acceleration time (1)	F002 (high)	R/W	0 to 360000	0.01 [s]
1104h		F002 (low)			
1105h	Deceleration time (1)	F003 (high)	R/W	0 to 360000	0.01 [s]
1106h		F003 (low)			
1107h	Keypad Run key routing	F004	R/W	0 (forward rotation), 1 (reverse rotation)	-
1108h to 1200h	Unused	-	-	Inaccessible	-

Chapter 8 Communication Functions

(3) Registers (group A)

Register No.	Function name	Function code	R/W	Monitoring and setting items	Data resolution
1201h	Frequency source	A001	R/W	0 (keypad potentiometer), 1 (control circuit terminal block), 2 (digital operator), 3 (Modbus), 10 (operation function result)	-
1202h	Run command source (*)	A002	R/W	1 (control circuit terminal block), 2 (digital operator), 3 (Modbus)	-
1203h	Base frequency	A003	R/W	300 to "maximum frequency"	0.1 [Hz]
1204h	Maximum frequency	A004	R/W	300 to 4000	0.1 [Hz]
1205h to 120Ah	(Reserved)	-	-	-	-
120Bh	(Reserved)	-	-	-	-
120Ch	[O/OI] input active range start frequency	A011	R/W	0 to 40000	0.01 [Hz]
120Dh	(Reserved)	-	-	-	-
120Eh	[O/OI] input active range end frequency	A012	R/W	0 to 40000	0.01 [Hz]
120Fh	[O/OI] input active range start voltage/current	A013	R/W	0 to "[O/OI]-[L] input active range end voltage/current"	1 [%]
1210h	[O/OI] input active range end voltage/current	A014	R/W	"[O/OI]-[L] input active range start voltage/current" to 100	1 [%]
1211h	[O/OI] input start frequency select	A015	R/W	0 (external start frequency), 1 (0 Hz)	-
1212h	Analog input filter.	A016	R/W	1 to 30 or 31 (500 ms filter ± 0.1 Hz with hysteresis)	1
1213h	(Reserved)	-	-	-	-
1214h	(Reserved)	-	-	-	-
1215h	Multi speed operation selection	A019	R/W	0 (binary), 1 (bit)	-
1216h	(Reserved)	-	-	-	-
1217h	Multi-speed freq. 0	A020	R/W	0 or "start frequency" to "maximum frequency"	0.01 [Hz]
1218h	(Reserved)	-	-	-	-
1219h	Multi-speed freq. 1	A021	R/W	0 or "start frequency" to "maximum frequency"	0.01 [Hz]
121Ah	(Reserved)	-	-	-	-
121Bh	Multi-speed freq. 2	A022	R/W	0 or "start frequency" to "maximum frequency"	0.01 [Hz]
121Ch	(Reserved)	-	-	-	-
121Dh	Multi-speed freq. 3	A023	R/W	0 or "start frequency" to "maximum frequency"	0.01 [Hz]
121Eh	(Reserved)	-	-	-	-
121Fh	Multi-speed freq. 4	A024	R/W	0 or "start frequency" to "maximum frequency"	0.01 [Hz]
1220h	(Reserved)	-	-	-	-
1221h	Multi-speed freq. 5	A025	R/W	0 or "start frequency" to "maximum frequency"	0.01 [Hz]
1222h	(Reserved)	-	-	-	-
1223h	Multi-speed freq. 6	A026	R/W	0 or "start frequency" to "maximum frequency"	0.01 [Hz]
1224h	(Reserved)	-	-	-	-
1225h	Multi-speed freq. 7	A027	R/W	0 or "start frequency" to "maximum frequency"	0.01 [Hz]

*)After changing the setting, keep the time 40ms or longer before actually give run command.

Chapter 8 Communication Functions

Register No.	Function name	Function code	R/W	Monitoring and setting items	Data resolution
1226h to 1237h	(Reserved)	-	-	-	-
1238h	Jog frequency	A038	R/W	"Start frequency" to 999	0.01 [Hz]
1239h	Jog stop mode	A039	R/W	0 (free-running after jogging stops [disabled during operation]) 1 (deceleration and stop after jogging stops [disabled during operation]) 2 (DC braking after jogging stops [disabled during operation]) 3 (free-running after jogging stops [enabled during operation]) 4 (deceleration and stop after jogging stops [enabled during operation]) 5 (DC braking after jogging stops [enabled during operation])	-
123Ah	(Reserved)	-	-	-	-
123Bh	Torque boost method selection	A041	R/W	0 (manual torque boost), 1 (automatic torque boost)	-
123Ch	Manual torque boost value	A042	R/W	0 to 200	0.1 [%]
123Dh	Manual torque boost frequency	A043	R/W	0 to 500	0.1 [%]
123Eh	V/F characteristic curve selection, 1st motor	A044	R/W	0 (VC), 1 (VP), 2 (free V/f)	-
123Fh	V/f gain	A045	R/W	20 to 100	1 [%]
1240h	Voltage compensation gain setting for automatic torque boost, 1st motor	A046	R/W	0 to 255	1 [%]
1241h	Slippage compensation gain setting for automatic torque boost, 1st motor	A047	R/W	0 to 255	1 [%]
1242h to 1244h	(Reserved)	-	-	-	-
1245h	DC braking enable	A051	R/W	0 (disabling), 1 (enabling), 2 (output freq < [A052])	-
1246h	DC braking frequency	A052	R/W	0 to 6000	0.01 [Hz]
1247h	DC braking wait time	A053	R/W	0 to 50	0.1 [s]
1248h	DC braking force during deceleration	A054	R/W	0 to 100	1 [%]
1249h	DC braking time for deceleration	A055	R/W	0 to 100	0.1 [s]
124Ah	DC braking/edge or level detection for [DB] input	A056	R/W	0 (edge operation), 1 (level operation)	-
124Bh	DC braking force for starting	A057	R/W	0 to 100	1 [%]
124Ch	DC braking time for starting	A058	R/W	0 to 100	0.1 [s]
124Dh	DC braking carrier frequency setting	A059	R/W	20 to 150	0.1 [kHz]
124Eh	(Reserved)	-	-	-	-

Chapter 8 Communication Functions

Register No.	Function name	Function code	R/W	Monitoring and setting items	Data resolution
124Fh	(Reserved)	-	-	-	-
1250h	Frequency upper limit	A061	R/W	0 or "maximum frequency limit" to "maximum frequency"	0.01 [Hz]
1251h	(Reserved)	-	-	-	-
1252h	Frequency lower limit	A062	R/W	0 or "maximum frequency limit" to "maximum frequency"	0.01 [Hz]
1253h	(Reserved)	-	-	-	-
1254h	Jump freq. (center) 1	A063	R/W	0 to 40000	0.01 [Hz]
1255h	Jump freq. width(hysteresis) 1	A064	R/W	0 to 1000	0.01 [Hz]
1256h	(Reserved)	-	-	-	-
1257h	Jump freq. (center) 2	A065	R/W	0 to 40000	0.01 [Hz]
1258h	Jump freq. width(hysteresis) 2	A066	R/W	0 to 1000	0.01 [Hz]
1259h	(Reserved)	-	-	-	-
125Ah	Jump freq. (center) 3	A067	R/W	0 to 40000	0.01 [Hz]
125Bh	Jump freq. width(hysteresis) 3	A068	R/W	0 to 1000	0.01 [Hz]
125Ch	(Reserved)	-	-	-	-
125Dh	Acceleration hold frequency	A069	R/W	0 to 40000	0.01 [Hz]
125Eh	Acceleration hold time	A070	R/W	0 to 600	0.1 [s]
125Fh	PID Function Enable	A071	R/W	0 (disabling), 1 (enabling), 2 (enabling inverted-data output)	-
1260h	PID proportional gain	A072	R/W	0 to 2500	0.01
1261h	PID integral time constant	A073	R/W	0 to 36000	0.1 [s]
1262h	PID derivative gain	A074	R/W	0 to 10000	0.01 [s]
1263h	PV scale conversion	A075	R/W	1 to 9999	0.01
1264h	PV source	A076	R/W	1 (input via O/OI), 2 (external communication), 10 (operation result output)	-
1265h	Reverse PID	A077	R/W	00 (disabling), 01 (enabling)	-
1266h	PID output limiter	A078	R/W	0 to 1000	0.1 [%]
1267h	(Reserved)	-	-	-	-
1268h	(Reserved)	-	-	-	-
1269h	AVR function select	A081	R/W	0 (always on), 1 (always off), 2 (off during deceleration)	-
126Ah	AVR voltage select	A082	R/W	200 V class: 0 (200)/1 (215)/2 (220)/3 (230)/4 (240) 400 V class: 5(380)/ 6(400)/ 7(415)/ 8(440)/ 9(460)/ 10(480)	-
126Bh	AVR filter time constant	A083	R/W	0 to 1000	0.001[s]
126Ch	AVR deceleration gain	A084	R/W	50 to 200	1[%]
126Dh	Energy-saving operation mode	A085	R/W	0 (normal operation), 1 (energy-saving operation)	-
126Eh	Energy-saving mode tuning	A086	R/W	0 to 1000	0.1 [%]

Register No.	Function name	Function code	R/W	Monitoring and setting items	Data resolution
126Fh to 1273h	(Reserved)	-	-	-	
1274h	Acceleration time (2)	A092 (high)	R/W	0 to 360000	0.01 [s]
1275h		A092 (low)	R/W		
1276h	Deceleration time (2)	A093 (high)	R/W	0 to 360000	0.01 [s]
1277h		A093 (low)	R/W		
1278h	Select method to switch to Acc2/Dec2 profile	A094	R/W	0 (switching by 2CH terminal), 1 (switching by setting) 2 (Forward and reverse)	-
1279h	(Reserved)	-	-	-	-
127Ah	Acc1 to Acc2 frequency transition point	A095	R/W	0 to 40000	0.01 [Hz]
127Bh	(Reserved)	-	-	-	-
127Ch	Dec1 to Dec2 frequency transition point	A096	R/W	0 to 40000	0.01 [Hz]
127Dh	Acceleration curve selection	A097	R/W	0 (linear), 1 (S curve), 2 (U curve), 3 (inverted-U curve)	-
127Eh	Deceleration curve setting	A098	R/W	0 (linear), 1 (S curve), 2 (U curve), 3 (inverted-U curve)	-
127Fh to 12A4h	(Reserved)	-	-	-	-
12A5h	Acceleration curve constant	A131	R/W	1 (smallest swelling) to 10 (largest swelling)	-
12A6h	Deceleration curve constant	A132	R/W	1 (smallest swelling) to 10 (largest swelling)	-
12A7h to 12AEh	(Reserved)	-	-	-	-
12AFh	Operation-target frequency selection 1	A141	R/W	0 (digital operator), 1 (keypad potentiometer), 2 (input via O/OI), 4 (external communication)	-

Chapter 8 Communication Functions

Register No.	Function name	Function code	R/W	Monitoring and setting items	Data resolution
12B0h	Operation-target frequency selection 2	A142	R/W	0 (digital operator), 1 (keypad potentiometer), 2 (input via O/OI), 4 (external communication)	-
12B1h	Operator selection	A143	R/W	0 (addition: A141 + A142), 1 (subtraction: A141 - A142), 2 (multiplication: A141 x A142)	-
12B2h	(Reserved)	-	-	-	-
12B3h	(Reserved)	-	-	-	-
12B4h	Frequency to be added	A145	R/W	0 to 40000	0.01 [Hz]
12B5h	Sign of the frequency to be added	A146	R/W	00 (frequency command + A145), 01 (frequency command - A145)	-
12B6h to 12BCh	(Reserved)	-	-	-	-
12BDh	(Reserved)	-	-	-	-
12BEh	Deceleration hold frequency	A154	R/W	0~40000	0.01 [Hz]
12BFh	Deceleration hold time	A155	R/W	0~600	0.1 [s]
12C0h	(Reserved)	-	-	-	-
12C1h	PID sleep function triggering level	A156	R/W	0~40000	0.01 [Hz]
12C2h	PID sleep function action delay time	A157	R/W	0~255	0.1 [s]
12C3h to 12C5h	(Reserved)	-	-	-	-
12C6h	(Reserved)	-	-	-	-
12C7h	[VR] input active range start frequency	A161	R/W	0~40000	0.01 [Hz]
12C8h	(Reserved)	-	-	-	-
12C9h	[VR] input active range end frequency	A162	R/W	0~40000	0.01 [Hz]
12CAh	[VR] input active range start %	A163	R/W	0~100	1 [%]
12CBh	[VR] input active range end %	A164	R/W	0~100	1 [%]
12CC	[VR] input start frequency select	A165	R/W	0(start frequency A161) / 1(0Hz)	-
12CDh to 1300h	unused	-	-	Inaccessible	-

(4) Registers (group B)

Register No.	Function name	Function code	R/W	Monitoring and setting items	Data resolution
1301h	Restart mode on power failure / under-voltage trip	b001	R/W	0 (tripping), 1 (starting with 0 Hz), 2 (starting with matching frequency), 3 (tripping after deceleration and stopping with matching frequency)	-
1302h	Allowable under-voltage power failure time	b002	R/W	3 to 250	0.1 [s]
1303h	Retry wait time before motor restart	b003	R/W	3 to 1000	0.1 [s]
1304h	Instantaneous power failure/under-voltage trip alarm enable	b004	R/W	0 (disabling), 1 (enabling), 2 (disabling during stopping and decelerating to stop)	-
1305h	Number of restarts on power failure/under-voltage trip events	b005	R/W	0 (16 times), 1 (unlimited)	-
1306h	(Reserved)	-	-	-	-
1307h	(Reserved)	-	-	-	-
1308h	Restart frequency threshold	b007	R/W	0 to 40000	0.01 [Hz]
1309h	Restart mode on over voltage / over current	b008	R/W	0 (tripping), 1 (starting with 0 Hz), 2 (starting with matching frequency), 3 (tripping after deceleration and stopping with matching frequency)	-
130Ah	(Reserved)	-	-	-	-
130Bh	Number of retry on over voltage / over current	b010	R/W	1 to 3	1 [times]
130Ch	Retry wait time on over voltage / over current	b011	R/W	3 to 1000	0.1 [s]
130Dh	Level of electronic thermal	b012	R/W	2000 to 10000	0.01 [%]
130Eh	Electronic thermal characteristic	b013	R/W	0 (reduced-torque characteristic), 1 (constant-torque characteristic), 2 (free setting)	-
130Fh	(Reserved)	-	-	Inaccessible	-
1310h	Free setting, electronic thermal frequency (1)	b015	R/W	0 to 400	1 [Hz]
1311h	Free setting, electronic thermal current (1)	b016	R/W	0 to 10000	0.01 [%]
1312h	Free setting, electronic thermal frequency (2)	b017	R/W	0 to 400	1 [Hz]
1313h	Free setting, electronic thermal current (2)	b018	R/W	0 to 10000	0.01 [%]
1314h	Free setting, electronic thermal frequency (3)	b019	R/W	0 to 400	1 [Hz]
1315h	Free setting, electronic thermal current (3)	b020	R/W	0 to 10000	0.01 [%]
1316h	Overload restriction operation mode	b021	R/W	0 (disabling), 1 (enabling during acceleration and constant-speed operation), 2 (enabling during constant-speed operation)	-
1317h	Overload restriction level	b022	R/W	2000 to 20000	0.01 [%]
1318h	Deceleration rate at overload restriction	b023	R/W	1 to 30000	0.1 [s]
1319h	Overload restriction operation mode (2)	b024	R/W	0 (disabling), 1 (enabling during acceleration and constant-speed operation), 2 (enabling during constant-speed operation)	-
131Ah	Overload restriction level 2	b025	R/W	2000 to 20000	0.01 [%]
131Bh	Deceleration rate at overload restriction (2)	b026	R/W	1 to 30000	0.1 [s]
131Ch	Over current suppression enable	b027	R/W	0 (disabling), 1 (enabling)	-
131Dh	Current level of active freq. matching	b028	R/W	1000 to 20000	0.01 [%]
131Eh	Deceleration rate of active freq. matching	b029	R/W	1 to 30000	0.1 [s]

Chapter 8 Communication Functions

Register No.	Function name	Function code	R/W	Monitoring and setting items	Data resolution
131Fh	Start freq. of active frequency matching	b030	R/W	0 (frequency at the last shutoff), 1 (maximum frequency), 2 (set frequency)	-
1320h	Software lock mode selection	b031	R/W	0 (disabling change of data other than "b031" when SFT is on), 1 (disabling change of data other than "b031" and frequency settings when SFT is on), 2 (disabling change of data other than "b031"), 3 (disabling change of data other than "b031" and frequency settings), 10 (enabling data changes during operation)	-
1321h	(Reserved)	-	-	-	-
1322h	(Reserved)	-	-	-	-
1323h	Run/power-on warning time	b034 (high)	R/W	0 to 65535	1 [10h]
1324h		b034 (low)	R/W		
1325h	Rotation direction restriction	b035	R/W	0 (Enable for both dir)/ 1 (Enable for forward only)/ 2 (Enable for reverse only)	-
1326h	Reduced voltage start selection	b036	R/W	0 (minimum reduced voltage start time) to 250 (maximum reduced voltage start time)	-
1327h	Function code display restriction	b037	R/W	0 (full display), 1 (function-specific display), 3 (data comparison display), 4 (basic display), 5 (monitor display)	-
1328h	Initial display selection	b038	R/W	000,001-060/201/202	-
1329h to 1333h	(Reserved)	-	-	-	-
1334h	Controlled deceleration on power loss	b050	R/W	0 (disabling), 1 (enabling), 2, (nonstop operation at momentary power failure (no restoration)) 3, (nonstop operation at momentary power failure (restoration to be done))	-
1335h	DC bus voltage trigger level of ctrl. decel.	b051	R/W	0 to 4000	0.1 [V]
1336h	Over-voltage threshold of ctrl. decel.	b052	R/W	0 to 4000	0.1 [V]
1337h	Deceleration time of ctrl. decel.	b053 (high)	R/W	1 to 30000	0.01 [s]
1338h		b053 (low)	R/W		
1339h	Initial freq. drop of ctrl. decel.	b054	R/W	0 to 1000	0.01 [Hz]
133Ah to 133Eh	(Reserved)	-	-	-	-
133Fh	Maximum-limit level of window comparators O	b060	R/W	0. to 100. (lower limit : b061 + b062 *2) (%)	1 [%]
1340h	Minimum-limit level of window comparators O	b061	R/W	0. to 100. (lower limit : b060 - b062*2) (%)	1 [%]
1341h	Hysteresis width of window comparators O	b062	R/W	0. to 10. (lower limit : b061 - b062 / 2) (%)	1 [%]

Register No.	Function name	Function code	R/W	Monitoring and setting items	Data resolution
1342h to 1348h	(Reserved)	-	-	-	-
1349h	Operation level at O disconnection	b070	R/W	0. to 100. (%) or "no" (ignore)	1 [%]
134Ah to 1350h	(reserved)	-	-	-	-
1351h	Cumulative input power data clearance	b078	R/W	Clearance by setting "1"	-
1352h	Watt-hour display gain	b079	R/W	1 to 1000	1
1353h to 1354h	(Reserved)	-	-	-	-
1355h	Start frequency	b082	R/W	1 to 999	0.01 [Hz]
1356h	Carrier frequency	b083	R/W	20 to 150	0.1 [kHz]
1357h	Initialization mode (parameters or trip history)	b084	R/W	0(disabling), 1 (clearing the trip history), 2 (initializing the data), 3 (clearing the trip history and initializing the data)	-
1358h	Country code for initialization	b085	R/W	0 (area A), 1 (area B), 3(area D)	-
1359h	Frequency scaling conversion factor	b086	R/W	1 to 9999	0.01
135Ah	STOP key enable	b087	R/W	0 :ON(enabling), 1 :OFF (disabling), 2 :Only Reset(disabling only stop)	-
135Bh	Restart mode after FRS	b088	R/W	0 (starting with 0 Hz), 1 (starting with matching frequency)	-
135Ch	Automatic carrier frequency reduction	b089	R/W	0(disabling)/1(enabling(output current controlled))	-
135Dh	(Reserved)	-	-	-	-
135Eh	Stop mode selection	b091	R/W	0 (deceleration until stop), 1 (free-run stop)	-
135Fh	(Reserved)	-	-	-	-
1360h	(Reserved)	-	-	-	-
1361h	Initialization target data	b094	R/W	0(All parameter) /1(expect terminal and communication)	-
1362h to 1366h	(Reserved)	-	-	-	-
1367h	Free-setting V/f frequency (1)	b100	R/W	0. to "free-setting V/f frequency (2)"	1 [Hz]
1368h	Free-setting V/f voltage (1)	b101	R/W	200V:0. to 3000 400 V:0. to 6000	0.1 [V]
1369h	Free-setting V/f frequency (2)	b102	R/W	0. to "free-setting V/f frequency (3)"	1 [Hz]
136Ah	Free-setting V/f voltage (2)	b103	R/W	200V:0. to 3000 400 V:0. to 6000	0.1 [V]
136Bh	Free-setting V/f frequency (3)	b104	R/W	0. to "free-setting V/f frequency (4)"	1 [Hz]
136Ch	Free-setting V/f voltage (3)	b105	R/W	200V:0. to 3000 400 V:0. to 6000	0.1 [V]
136Dh	Free-setting V/f frequency (4)	b106	R/W	0. to "free-setting V/f frequency (5)"	1 [Hz]
136Eh	Free-setting V/f voltage (4)	b107	R/W	200V:0. to 3000 400 V:0. to 6000	0.1 [V]
136Fh	Free-setting V/f frequency (5)	b108	R/W	0. to "free-setting V/f frequency (6)"	1 [Hz]
1370h	Free-setting V/f voltage (5)	b109	R/W	200V:0. to 3000 400 V:0. to 6000	0.1 [V]
1371h	Free-setting V/f frequency (6)	b110	R/W	0. to "free-setting V/f frequency (7)"	1 [Hz]
1372h	Free-setting V/f voltage (6)	b111	R/W	200V:0. to 3000 400 V:0. to 6000	0.1 [V]
1373h	Free-setting V/f frequency (7)	b112	R/W	0. to 400.	1 [Hz]
1374h	Free-setting V/f voltage (7)	b113	R/W	200V:0. to 3000 400 V:0. to 6000	0.1 [V]

Chapter 8 Communication Functions

Register No.	Function name	Function code	R/W	Monitoring and setting items	Data resolution
1375h to 1384h	(Reserved)	-	-	-	-
1385h	Deceleration over voltage suppression enable	b130	R/W	0 (disabling), 1 (enabling), 2 (enabling with acceleration), 3 (when Const/Dec)	-
1386h	Decel. over volt. suppress level	b131	R/W	200 V class: 330 to 390 (V) 400 V class: 660 to 780 (V)	1 [V]
1387h	Decel. over volt. suppress const.	b132	R/W	10 to 3000	0.01 [s]
1388h	Decel. overvolt. suppress propotional gain	b133	R/W	0 to 500	0.01
1389h	Decel. overvolt. suppress Integral time	b134	R/W	0 to 1500	0.1 [s]
138Ah to 1398h	(Reserved)	-	-	-	-
1399h	Display ex.operator connected	b150	R/W	1 to 60h(BCD) (d001 to d060) [exe. 15h : d015]	-
139Ah to 13A2h	(Reserved)	-	-	-	-
13A3h	1st parameter of Dual Monitor	b160	R/W	1 to 18h(BCD) (d001 to d018) [exe. 15h : d015]	-
13A4h	2nd parameter of Dual Monitor	b161	R/W	1 to 18h(BCD) (d001 to d018) [exe. 15h : d015]	-
13A5h	(Reserved)	-	-	-	-
13A6h	Freq. set in monitoring	b163	R/W	0 (disabling), 1 (enabling)	-
13A7h	Automatic return to the initial display	b164	R/W	0 (disabling), 1 (enabling)	-
13A8h	Ex. operator com. loss action	b165	R/W	0 (tripping), 1 (tripping after decelerating and stopping the motor), 2 (ignoring errors), 3 (stopping the motor after free-running), 4 (decelerating and stopping the motor)	-
13A9h	Data Read/Write select	b166	R/W	0 (Read/Write OK) / 1 (Protected)	-
13AAh to 13B6h	(Reserved)	-	-	-	-
13B7h	Initialization trigger	b180	R/W	0 (disabling), 1 (enabling)	-
13B8h to 1400h	unused	-	-	Inaccessible	-

(5) Registers (group C)

Register No.	Function name	Function code	R/W	Monitoring and setting items	Data resolution
1401h	Input [1] function	C001	R/W	0 (Forward Run), 1 (RV: Reverse RUN), 2 (CF1: Multispeed 1 setting), 3 (CF2: Multispeed 2 setting), 4 (CF3: Multispeed 3 setting), 6 (JG: Jogging), 7 (DB: external DC braking), 8 (SET: Set 2nd motor data), 9 (2CH: 2-stage acceleration/deceleration), 11 (FRS: free-run stop), 12 (EXT: external trip), 13 (USP: unattended start protection), 15 (SFT: software lock), 18 (RS: reset), 20 (STA: starting by 3-wire input), 21 (STP: stopping by 3-wire input), 22 (F/R: forward/reverse switching by 3-wire input), 23 (PID: PID disable), 24 (PIDC: PID reset), 27 (UP: remote control UP function), 28 (DWN: remote control DOWN function), 29 (UDC: remote control data clearing), 31 (OPE: forcible operation), 32 (SF1: multispeed bit 1), 33 (SF2: multispeed bit 2), 34 (SF3: multispeed bit 3), 39 (OLR: overload restriction selection), 50 (ADD: trigger for frequency addition [A145]), 51 (F-TM: forcible-terminal operation), 53 (KHC: cumulative power clearance), 65 (AHD: analog command holding), 83 (HLD: retain output frequency), 84 (ROK: permission of run command), 86 (DISP: Display limitation), 255 (no: no assignment),	-
1402h	Input [2] function	C002	R/W		-
1403h	Input [3] function	C003	R/W		-
1404h	Input [4] function	C004	R/W		-
1405h	Input [5] function	C005	R/W		-
1406h to 140Ah	(Reserved)	-	-	Inaccessible	-
140Bh	Input [1] active state	C011	R/W	0 (NO), 1 (NC)	-
140Ch	Input [2] active state	C012	R/W	0 (NO), 1 (NC)	-
140Dh	Input [3] active state	C013	R/W	0 (NO), 1 (NC)	-
140Eh	Input [4] active state	C014	R/W	0 (NO), 1 (NC)	-
140Fh	Input [5] active state	C015	R/W	0 (NO), 1 (NC)	-
1410h to 1414h	(Reserved)	-	-	Inaccessible	-

Chapter 8 Communication Functions

Register No.	Function name	Function code	R/W	Monitoring and setting items	Data resolution
1415h	Output [11] function	C021	R/W	0 (RUN: running), 1 (FA1: constant-speed reached), 2 (FA2: set frequency overreached), 3 (OL: overload notice advance signal (1)), 4 (OD: output deviation for PID control), 5 (AL: alarm signal), 6 (FA3: set frequency reached), 9 (UV: undervoltage), 11 (RNT: operation time over), 12 (ONT: plug-in time over), 13 (THM: thermal alarm signal), 21 (ZS: 0 Hz detection signal), 31 (FBV: PID feedback comparison), 32 (NDC: communication line disconnection), 33 (LOG1: logical operation result 1), 41 (FR: starting contact signal), 42 (OHF: heat sink overheat warning), 43 (LOC: low-current indication signal), 50 (IRDY: inverter ready), 51 (FWR: forward rotation), 52 (RVR: reverse rotation), 53 (MJA: major failure)	-
1416h to 1419h	(Reserved)	-	-	54 (WCO: window comparator O), 58 (FREF), 59 (REF), 60 (SETM), 255 (no: no assignment)	-
141Ah	Alarm relay function	C026	R/W	0 (output frequency), 1 (output current), 3 (digital output frequency), 4 (output voltage), 5 (input power), 6 (electronic thermal overload), 7 (LAD frequency), 8 (digital current monitoring), 10 (heat sink temperature)	-
141Bh	[FM] terminal selection	C027	R/W		-
141Ch	(reserved)	-	-		-
141Dh	(reserved)	-	-		-
141Eh	Digital current monitor reference value	C030	R/W	2000 to 20000	0.01 [%]
141Fh	Output [11] active state	C031	R/W	0 (NO), 1 (NC)	-
1420h to 1423h	(Reserved)	-	-		-
1424h	Alarm relay active state	C036	R/W	0 (NO), 1 (NC)	-
1425h	(Reserved)	-	-		-
1426h	Output mode of low current detection	C038	R/W	0 (output during acceleration/deceleration and constant-speed operation), 1 (output only during constant-speed operation)	-
1427h	Low current detection level	C039	R/W	0 to 20000	0.01 [%]
1428h	Overload signal output mode	C040	R/W	00 (output during acceleration/deceleration and constant-speed operation), 01 (output only during constant-speed operation)	-
1429h	Overload warning level	C041	R/W	0 to 20000	0.01 [%]

Chapter 8 Communication Functions

Register No.	Function name	Function code	R/W	Monitoring and setting items	Data resolution
142Ah	(Reserved)	-	-	-	-
142Bh	Frequency arrival setting for accel.	C042	R/W	0 to 40000	0.01 [Hz]
142Ch	(Reserved)	-	-	-	-
142Dh	Frequency arrival setting for decel.	C043	R/W	0 to 40000	0.01 [Hz]
142Eh	PID deviation level	C044	R/W	0 to 1000	0.1 [%]
142Fh to 1437h	(Reserved)	-	-	-	-
1438h	Maximum PID feedback data	C052	R/W	0 to 1000	0.1 [%]
1439h	Minimum PID feedback data	C053	R/W	0 to 1000	0.1 [%]
143Ah to 1440h	(Reserved)	-	-	-	-
1441h	Electronic thermal warning level	C061	R/W	0 to 100	1 [%]
1442h	(Reserved)	-	-	-	-
1443h	Zero speed detection level	C063	R/W	0 to 10000	0.01 [Hz]
1444h	Heat sink overheat warning level	C064	R/W	0 to 110	1 [°c]
1445h to 1449h	(Reserved)	-	-	-	-
144Ah	Selection of OPE/Modbus	C070	R/W	0 (OPE) / 1 (Modbus)	-
144Bh	Communication speed	C071	R/W	4(4800bps), 5(9600bps), 6(19.2kbps), 7(38.4kbps)	-
144Ch	Modbus address	C072	R/W	1. to 247.	-
144Dh	(Reserved)	-	-	-	-
144Eh	Communication parity	C074	R/W	0 (no parity), 1 (even parity), 2 (odd parity)	-
144Fh	Communication stop bit	C075	R/W	1 (1 bit), 2 (2 bits)	-
1450h	Selection of the operation after communication error	C076	R/W	0 (tripping), 1 (tripping after decelerating and stopping the motor), 2 (ignoring errors), 3 (stopping the motor after free-running), 4 (decelerating and stopping the motor)	-
1451h	Communication timeout limit	C077	R/W	0 to 9999	0.01 [s]
1452h	Communication wait time	C078	R/W	0 to 1000	1 [ms]
1453h to 1454h	(Reserved)	-	-	-	-
1455h	[O/O] input span calibration	C081	R/W	0 to 2000	0.1
1456h to 145Eh	(Reserved)	-	-	-	-
145Fh	Debug mode enable	C091	R	0/1	-
1460h to 1468h	(Reserved)	-	-	-	-

Chapter 8 Communication Functions

Register No.	Function name	Function code	R/W	Monitoring and setting items	Data resolution
1469h	Up/Down memory mode selection	C101	R/W	0 (not storing the frequency data), 1 (storing the frequency data)	-
146Ah	Reset mode selection	C102	R/W	0 (resetting the trip when RS is on), 1 (resetting the trip when RS is off), 2 (enabling resetting only upon tripping [resetting when RS is on])	-
146Bh	Restart mode after reset	C103	R/W	0 (starting with 0 Hz), 1 (starting with matching frequency)	-
146Ch	UP/DWN clear mode	C104	R/W	0 (0Hz) /1 (when power supply is turned on)	-
146Dh	FM gain adjustment	C105	R/W	50 to 200	1 [%]
146Eh to 1485h	(Reserved)	-	-	-	-
1486h	Output [11] on-delay time	C130	R/W	0 to 1000	0.1 [s]
1487h	Output [11] off-delay time	C131	R/W	0 to 1000	0.1 [s]
1488h to 148F	(Reserved)	-	-	-	-
1490h	Output RY on-delay time	C140	R/W	0 to 1000	0.1 [s]
1491h	Output RY off-delay time	C141	R/W	0 to 1000	0.1 [s]
1492h	Logic output 1 operand A	C142	R/W	Same as the settings of C021 to C026 (except those of LOG1,no)	-
1493h	Logic output 1 operand B	C143	R/W	Same as the settings of C021 to C026 (except those of LOG1,no)	-
1494h	Logical output 1 operator	C144	R/W	0 (AND), 1 (OR), 2 (XOR)	-
1495h to 149Ah	(Reserved)	-	-	-	-
149Bh	Button sensitivity selection	C151	R/W	0 to 250 / no(255)	-
149Ch	Scroll sensitivity selection	C152	R/W	1 to 20	-
149Dh to 14A3h	(Reserved)	-	-	-	-
14A4h	Input [1] response time	C160	R/W	0 to 200	
14A5h	Input [2] response time	C161	R/W	0 to 200	
14A6h	Input [3] response time	C162	R/W	0 to 200	
14A7h	Input [4] response time	C163	R/W	0 to 200	
14A8h	Input [5] response time	C164	R/W	0 to 200	
14A9h to 14ACh	(Reserved)	-	-	-	
14ADh	Multistage speed determination time	C169	R/W	0 to 200	
14A4h to 1500h	unused	-	-	Inaccessible	-

(6) Registers (group H)

Register No.	Function name	Function code	R/W	Monitoring and setting items	Data resolution
1501h	(Reserved)	-	-	-	
1502h	(Reserved)	-	-	-	
1503h	Motor capacity, 1st motor	H003	R/W	0(0.1kW)-11 (5.5kW)	-
1504h	Motor poles setting, 1st motor	H004	R/W	0 (2 poles), 1 (4 poles), 2 (6 poles), 3 (8 poles)	-
1505h	(Reserved)	-	-	-	
1506h	(Reserved)	-	-	-	
1507h	Motor stabilization constant, 1st motor	H006	R/W	0 to 255	1
1508h to 2102h	unused	-	-	Inaccessible	-

(7) Registers (2nd control settings F group)

Register No.	Function name	Function code	R/W	Monitoring and setting items	Data resolution
2103h	Acceleration time (1), 2nd motor	F202 (high)	R/W	0 to 360000	0.01 [s]
2104h		F202 (low)	R/W		
2105h	Deceleration time (1), 2nd motor	F203 (high)	R/W	0 to 360000	0.01 [s]
2106h		F203 (low)	R/W		
2107h to 2200h	unused	-	-	Inaccessible	-

(8) Registers (2nd control settings A,B,C,H group)

Register No.	Function name	Function code	R/W	Monitoring and setting items	Data resolution
2201h	Frequency source, 2nd motor	A201	R/W	0 (keypad potentiometer), 1 (control circuit terminal block), 2 (digital operator), 3 (Modbus), 10 (operation function result)	-
2202h	Frequency source, 2nd motor	A202	R/W	1 (control circuit terminal block), 2 (digital operator), 3 (Modbus)	-
2203h	Base frequency, 2nd motor	A203	R/W	300 to "maximum frequency, 2nd motor"	0.1 [Hz]
2204h	Maximum frequency, 2nd motor	A204	R/W	300 to 4000	0.1 [Hz]
2205h to 2215h	(Reserved)	-	-	Inaccessible	-
2216h	(Reserved)	-	-	Inaccessible	-
2217h	Multispeed frequency setting, 2nd motor	A220	R/W	0 or "start frequency" to "maximum frequency, 2nd motor"	0.01 [Hz]
2218h to 223Ah	(Reserved)	-	-	Inaccessible	-
223Bh	Torque boost method selection, 2nd motor	A241	R/W	0 (manual torque boost), 1 (automatic torque boost)	-
223Ch	Manual torque boost value, 2nd motor	A242	R/W	0 to 200	0.1 [%]
223Dh	Manual torque boost frequency, 2nd motor	A243	R/W	0 to 500	0.1 [%]
223Eh	V/F characteristic curve selection, 2nd motor	A244	R/W	0 (VC), 1 (VP), 2 (free V/f)	-
223Fh	V/f gain, 2nd motor	A245	R/W	20 to 100	1 [%]
2240h	Voltage compensation gain setting for automatic torque boost, 2nd motor	A246	R/W	0 to 255	1
2241h	Slippage compensation gain setting for automatic torque boost, 2nd motor	A247	R/W	0 to 255	1
2242h to 224Eh	(Reserved)	-	-	Inaccessible	-
224Fh	(Reserved)	-	-	Inaccessible	-
2250h	Frequency upper limit, 2nd motor	A261	R/W	00 or "2nd minimum frequency limit" to "maximum frequency, 2nd motor"	0.01 [Hz]
2251h	(Reserved)	-	-	Inaccessible	-
2252h	Frequency lower limit, 2nd motor	A262	R/W	00 or "start frequency" to "maximum frequency, 2nd motor limit"	0.01 [Hz]
2253h to 2268h	(Reserved)	-	-	Inaccessible	-
2269h	AVR function select, 2nd motor	A281	R/W	0 (always on), 1 (always off), 2 (off during deceleration)	-
226Ah	AVR voltage select, 2nd motor	A282	R/W	200 V class: 0 (200)/1 (215)/2 (220)/3 (230)/4 (240) 400V class: 5(380)/ 6(400)/ 7(415)/ 8(440)/ 9(460)/ 10(480)	-
226Bh to 226Eh	(Reserved)	-	-	Inaccessible	-

Chapter 8 Communication Functions

Register No.	Function name	Function code	R/W	Monitoring and setting items	Data resolution
226Fh	Acceleration time (2), 2nd motor	A292 (high)	R/W	0 to 360000	0.01 [s]
2270h		A292 (low)	R/W		
2271h	Deceleration time (2), 2nd motor	A293 (high)	R/W	0 to 360000	0.01 [s]
2272h		A293 (low)	R/W		
2273h	Select method to switch to Acc2/Dec2, 2nd motor	A294	R/W	0 (switching by 2CH terminal), 1 (switching by setting), 2 (switching only when the rotation is reversed)	-
2274h	(Reserved)	-	-	-	-
2275h	Acc1 to Acc2 frequency transition point, 2nd motor	A295	R/W	0 to 40000	0.01 [Hz]
2276h	(Reserved)	-	-	-	-
2277h	Dec1 to Dec2 frequency transition point, 2nd motor	A296	R/W	0 to 40000	0.01 [Hz]
2278h to 230Bh	(Reserved)	-	-	-	-
230Ch	Level of electronic thermal, 2nd motor	b212	R/W	2000 to 10000	0.01 [%]
230Dh	Electronic thermal characteristic, 2nd motor	b213	R/W	0 (reduced-torque characteristic), 1 (constant-torque characteristic), 2 (free setting)	-
230Eh to 2315h	(Reserved)	-	-	-	-
2316h	Overload restriction operation mode, 2nd motor	b221	R/W	0 (disabling), 1 (enabling during acceleration and constant-speed operation), 2 (enabling during constant-speed operation)	-
2317h	Overload restriction level, 2nd motor	b222	R/W	1000 to 20000	0.01[%]
2318h	Deceleration rate at overload restriction, 2nd motor	b223	R/W	1 to 30000	0.1[s]
2319h to 2428h	unused	-	-	Inaccessible	-
2429h	Overload warning level 2, 2nd motor	C241	R/W	0 to 20000	0.01[%]
242Ah to 2502h	Unused	-	-	Inaccessible	-
2503h	Motor capacity, 2nd motor	H203	R/W	0(0.1kW)- 11 (5.5kW)	-
2504h	Motor poles setting, 2nd motor	H204	R/W	0 (2 poles), 1 (4 poles), 2 (6 poles), 3 (8 poles)	-
2505h	(Reserved)	-	-	-	-
2506h	(Reserved)	-	-	-	-
2507h	Motor stabilization constant, 2nd motor	H206	R/W	0 to 255	1
2508h~	(Reserved)	-	-	Inaccessible	-

Chapter 9 Error Codes

This chapter describes the error codes of the inverter, error indications by the functions, and troubleshooting methods.

9.1	Indication of the error	9 - 1
9.2	Error Codes and Troubleshooting	9 - 3
9.3	Warning Codes for Digital operator	9 - 5
9.4	Other Display for Digital operator	9 - 6

9.1 Indication of the error

The microprocessor in the inverter detects a variety of fault conditions and captures the event, recording it in a history table. The inverter output turns OFF, or “trips” similar to the way a circuit breaker trips due to an over-current condition. Most faults occur when the motor is running (refer to the diagram to the right). However, the inverter could have an internal fault and trip in Stop Mode.

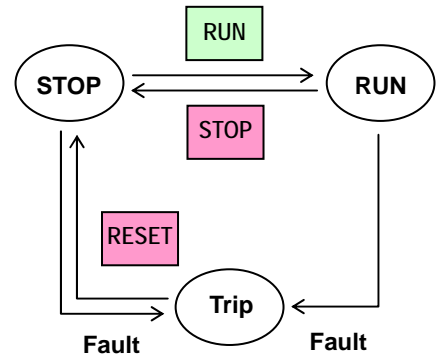

In either case, you can clear the fault by pressing the Reset key/terminal except some errors.

* How to remove the error condition

- a) Pressing the [RUN/STOP/RESET] key. ([STOP/RESET] key in the operator.)
- b) Intelligent input terminal is assigned reset(18:RS). And to operate the terminal.
- c) A power cycle of the inverter.

Note) Error by a factor may not be canceled by a reset a),b). In this case, please go to c).

[Standard panel]

The ALM (red) of the main body, LED indication of RUN (yellowish green) display it like a list shown below at the time of error outbreak.

Error contents	LED Lighting, Blinking	
	ALM LED	RUN LED
Over-current event	Lighting	Blinking
Over-voltage Note2)	Blinking : Same period	Blinking : Same period
Under-voltage Note3)	Blinking : Alternation	Blinking : Alternation
Over load	Lighting	Lighting
Major failure Note1)	Lighting	Lights out
Others Note4)	Blinking	Lights out

Note1) The Major fault : When a Memory error, Current detection error, CPU error, Ground fault , Thermal detection error

Note2) The blinking is a period for 1s. The condition of the blinking is blinking in Timing same as ALARM lamp, the RUN lamp.(At the time of the lighting, ALARM lamp, the RUN lamp turn on, too. At the time of lights out, be turned off the light by an ALARM lamp, RUN lamps.)

Note3) The blinking is a period for 1s. As for the condition of the blinking, ALARM lamp and RUN lamp repeat a flash in turn.(At the time of the ALARM lamp lighting, RUN lamp turns off the light. At the time of ALARM lamp lights out, RUN lamp turns on.)

Note4) As for other trips,Over-voltage protection,Inverter thermal detection system error,Driver error,Output single-phase error,Over-current event during low-speed,Operetor connection error(except NES1-OP), either of Modbus communication error .

Chapter 9 Error Codes

[Digital Operator (NES1-OP, OPE-S/SR/SBK/SRmini)]

Trip History and Inverter Status

We recommend that you first find the cause of the fault before clearing it. When a fault occurs, the inverter stores important performance data at the moment of the fault. To access the data, use the monitor function (dxxx) and select **d001** details about the present fault. The previous 5 faults are stored in **d002** to **d006**. Each error shifts **d001-d005** to **d002-d006**, and writes the new error to **d001**.

The following Monitor Menu map shows how to access the error codes. When fault(s) exist, you can review their details by first selecting the proper function: **d001** is the most recent, and **d006** is the oldest.

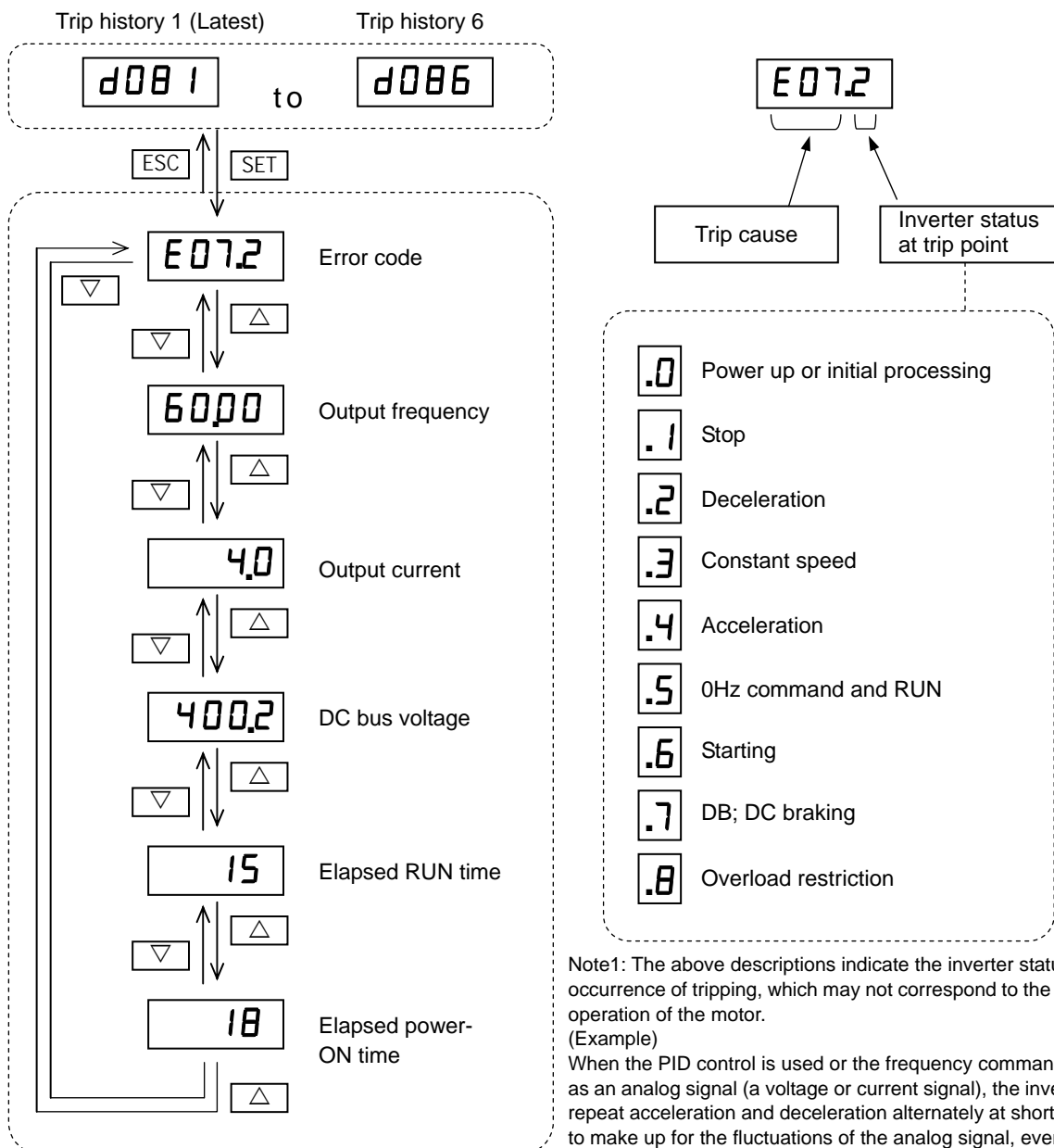











Note1: The above descriptions indicate the inverter status at the occurrence of tripping, which may not correspond to the apparent operation of the motor.
 (Example)
 When the PID control is used or the frequency command is input as an analog signal (a voltage or current signal), the inverter may repeat acceleration and deceleration alternately at short intervals to make up for the fluctuations of the analog signal, even if the motor is apparently running at constant speed.
 In such cases, the inverter status at tripping may not correspond to the apparent operation of the motor.

Note2: During undervoltage, detailed information of the trip (historical trail) is not stored.

9.2 Error Codes and Troubleshooting

It is not displayed with the standard panel.

Name	Description	Display on digital operator	Troubleshooting and corrective action	Reference page
Overcurrent protection	If the motor is constrained or suddenly accelerated or decelerated, a high current will flow in the inverter and the inverter may fail. To avoid this problem, the inverter shuts off its output and displays the error code shown on the right when it detects a current higher than a specified level. This protective function uses a DC current detector (CT) to detect overcurrent. When a current as high as about 235%(peak) of the inverter's rated output current is detected, the protective circuit operates and the inverter trips. (*4)	During constant-speed operation	 Check whether the load has fluctuated sharply. (Eliminate the load fluctuation.) Check for the short circuit of output connections. (Check the output cables.) Check for the ground fault. (Check the output cables and motor.)	7-8 7-22
		During deceleration	 Check whether the inverter has decelerated the motor quickly. (Increase the deceleration time.)	
		During acceleration	 Check whether the inverter has accelerated the motor quickly. (Increase the acceleration time.) Check whether the motor has been locked. (Check the motor and wiring.) Check whether the torque boost current has been set too high. (Reduce the boost current.)	
		Others	 Check whether the DC braking force is too high. (Reduce the braking force.) Check whether the current detector (CT) is normal. (Replace or repair the CT.)	7-41
Overload protection (*1)	This protective function monitors the inverter output current, and shuts off the inverter output and displays the error code shown on the right when the internal electronic thermal protection circuit detects a motor overload. If the error occurs, the inverter will trip according to the setting of the electronic thermal function.		Check whether the motor load is too high. (Reduce the load factor.) Check whether the thermal level is appropriate. (Adjust the level appropriately.) Note: The electronic thermal protection is easily triggered when the output frequency is 5 Hz or less. If the moment of inertia of the load is large, this protective function may operate when the inverter accelerates the motor and the acceleration may be disabled. If this problem occurs, increase the torque boost current or adjust other settings as needed.	7-61 7-63
Overvoltage protection	If the DC voltage across the P and N terminals rises too high, an inverter failure may result. To avoid this problem, this protective function shuts off the inverter output and displays the error code shown on the right when the DC voltage across the P and N terminals exceeds a specified level because of an increase in the energy regenerated by the motor or the input voltage (during operation). The inverter will trip if the DC voltage across the P and N terminals exceeds about 400 VDC (in case of the 200 V class models) or about 800 VDC (in case of the 400 V class models).		Check whether the inverter has decreased the motor quickly. (Increase the deceleration time.) Check for a ground fault. (Check the output cables and motor.) Check whether the motor has been rotated by the action of the load. (Reduce the regenerative energy.)	7-8
Memory error (*2) (*3)	When the built-in Memory is caused by external noise or an abnormal temperature rise, the inverter shuts off its output and displays the error code shown on the right. Note: A Memory error may cause a CPU error.		Check for the noise sources located near the inverter. (Remove noise sources.) Check whether the cooling efficiency has deteriorated. (Check the heat sink for clogging, and clean it.) (Replace the cooling fan.)	-
Under voltage	If the inverter input voltage drops, the control circuit of the inverter cannot function normally. Therefore, the inverter shuts off its output when the input voltage falls below a specified level. The inverter will trip if the DC voltage across the P and N terminals exceeds about 175 VDC (in case of the 200 V class models) or about 345 VDC (in case of the 400 V class models).		Check whether the power supply voltage has dropped. (Check the power supply.) Check whether the power supply capacity is sufficient. (Check the power supply.)	-
Current detection error	If an error occurs in the internal current detector (CT), the inverter will shut off its output and display the error code shown on the right.		Check whether the inverter has failed. (Repair the inverter.)	-
CPU error (*3)	If the internal CPU malfunctions or an error occurs in it, the inverter will shut off its output and display the error code shown on the right. Note: Reading an abnormal data from the built-in memory may result in a CPU error.		Check for the noise sources located near the inverter. (Remove noise sources.) Check whether the inverter has failed. (Repair the inverter.)	-

*1 The inverter will not accept any reset command within about 10 seconds after tripping (i.e., after the protective function operates).

*2 The inverter will not accept any reset command after a Memory error occurs with error code  displayed. Turn off the inverter power once. If error code "E08" is displayed when the inverter power is turned on subsequently, the internal memory device may have failed or parameters may have not been stored correctly. In such cases, initialize the inverter, and then re-set the parameters.

*3 The inverter will not accept reset commands input via the RS terminal or entered by the STOP/RESET key. Therefore, turn off the inverter power.

*4 At the time of trip occurrence, as for the effective-value electric current with the measuring instrument and the current value of the trip history, a low value may be displayed by timing of the data sampling.

Chapter 9 Error Codes

Name	Description	Display on digital operator	Troubleshooting and corrective action	Reference page
External trip	If an error occurs in the external equipment or device connected to the inverter, the inverter will fetch the error signal and shut off its output. (This protective function is enabled when the external trip function is enabled.)	E 12	Check whether an error has occurred in the external equipment (when the external trip function has been enabled). (Recover the external equipment from the error.)	-
USP error	A USP error is indicated when the inverter power is turned on with an input operation signal remaining in the inverter. (This protective function is enabled when the USP function is enabled.)	E 13	Check whether the inverter power has been turned on with an input operation signal remaining in the inverter (when the USP function has been enabled). (Reset the operation command, and then turn on the inverter power.)	7-57
Ground-fault protection (*3)	When the inverter power is turned on, this protective function detects the ground fault between the inverter output circuit and the motor to protect the inverter. (This function does not operate when a residual voltage remains in the motor.)	E 14	Check for the ground fault. (Check the output cables and motor.) Check the inverter itself for abnormality. (Remove the output cables from the inverter, and then check the inverter.)	7-76 11-4
Input overvoltage protection	This protective function determines an error if the input voltage is kept above the specification level for 100 seconds while the inverter is stopped.	E 15	Check whether the input voltage is high while the inverter is stopped. (Lower the input voltage, suppress the power voltage fluctuation, or connect an AC reactor between the power supply and the inverter input.)	-
Inverter thermal detection circuit error	When the thermal sensor in the inverter module is not function.	E 19	Check whether the inverter has failed. (Replace the inverter.)	-
Temperature error	If the main circuit temperature rises because of a high ambient temperature or for other reasons, the inverter will shut off its output.	E 21	Check whether the inverter is installed vertically. (Check the installation.) Check whether the ambient temperature is high. (Lower the ambient temperature.)	-
Driver error	If instantaneous overcurrent occurs, the main circuit element temperature is abnormal, or the main circuit element drive power drops, the inverter will shut off its output to protect the main circuit element. (After tripping because of this protective function, the inverter cannot retry the operation.)	E 30	Check the output circuit for a short circuit. (Check the output cables.) Check for the ground fault. (Check the output cables and motor.) Check the heat sink for clogging. (Clean the heat sink.)	5-7
Output phase loss protection	Output phase Loss Logic Detection.(There are undetectable terms of use)	E 34	Check for the output phase loss. (Check the Output Freq, carrier Freq current output cables and motor.)	7-76
Low-speed overload protection	If overload occurs during the motor operation at a very low speed, the electronic thermal protection circuit in the inverter will detect the overload and shut off the inverter output. (Note that a high frequency may be recorded as the error history data.)	E 38	Check whether the motor load is too high. (Reduce the load factor.)	-
Operator connection error	When the connection between inverter and operator keypad failed, inverter trips and displays the error code.	E 40	Check the operator cable.	-
Modbus communication error	If timeout occurs because of line disconnection during the communication in Modbus-RTU mode, the inverter will display the error code shown on the right. (The inverter will trip according to the setting of "C076".)	E 41	Check whether the communication speed setting is correct. Check whether the wiring distance is appropriate. (Check the connections.)	8-4

*3 The inverter will not accept reset commands input via the RS terminal or entered by the STOP/RESET key. Therefore, turn off the inverter power.

9.3 Warning Codes for Digital operator

The warning code for Digital operator is follows.

It is not displayed with the standard panel.

The inverter displays a warning code when the data set as a target function code satisfies the condition (specified in the Condition column) in relation to the data set as the corresponding basic function code.







Warning code	Condition		
H 001	Frequency upper limit setting (A061)	>	Maximum frequency setting (A004)
H 002	Frequency lower limit setting (A062)	>	Maximum frequency setting (A004)
H 005	Output frequency setting (F001), multispeed 0 (A020) (note 1)	>	Maximum frequency setting (A004)
H 015	Output frequency setting (F001), multispeed 0 (A020) (note 1)	>	Frequency upper limit setting (A061)
H 025	Frequency lower limit setting (A062)	>	Output frequency setting (F001), multispeed 0 (A020) (note 1)
H 031	Start frequency adjustment (b082)	>	Frequency upper limit setting (A061)
H 032	Start frequency adjustment (b082)	>	Frequency lower limit setting (A062)
H 035	Start frequency adjustment (b082)	>	Output frequency setting (F001), multispeed 0 (A020) (note 1)
H 037	Start frequency adjustment (b082)	>	Jog frequency setting (A038)
H 085	Output frequency setting (F001), multispeed 0 (A020) (note 1)	=	Jump (center) frequency settings 1/2/3 ± " Jump (hysteresis) frequency width settings 1/2/3" A063 ± A064, A065 ± A066, A067 ± A068
H 086	Multispeed 1 to 7 settings (A021 to A027)	=	
H 091	Free-setting V/f frequency (7) (b112)	<	Frequency upper limit setting (A061)
H 092	Free-setting V/f frequency (7) (b112)	<	Frequency lower limit setting (A062)
H 095	Free-setting V/f frequency (7) (b112)	<	Output frequency setting (F001), multispeed 0 (A020) (note 1)
H 201	Frequency upper limit setting (A261)	>	Maximum frequency setting (A204)
H 202	Frequency lower limit setting (A262)	>	Maximum frequency setting (A204)
H 205	Output frequency setting (F001), multispeed 0 (A220) (note 1)	>	Maximum frequency setting (A204)
H 215	Output frequency setting (F001), multispeed 0 (A220) (note 1)	>	Frequency upper limit setting (A261)
H 225	Frequency lower limit setting (A262)	>	Output frequency setting (F001), multispeed 0 (A220) (note 1)
H 231	Start frequency adjustment (b082)	>	Frequency upper limit setting (A261)
H 232	Start frequency adjustment (b082)	>	Frequency lower limit setting (A262)
H 235	Start frequency adjustment (b082)	>	Output frequency setting (F001), multispeed 0 (A220) (note 1)
H 285	Output frequency setting (F001), multispeed 0 (A220) (note 1)	=	Jump (center) frequency settings 1/2/3 ± " Jump (hysteresis) frequency width settings 1/2/3" A063 ± A064, A065 ± A066, A067 ± A068
H 291	Free-setting V/f frequency (7) (b112)	<	Frequency upper limit setting (A261)
H 292	Free-setting V/f frequency (7) (b112)	<	Frequency lower limit setting (A262)
H 295	Free-setting V/f frequency (7) (b112)	<	Output frequency setting (F001), multispeed 0 (A220) (note 1)

Note1)These parameters are checked, even when the digital operator (02) is not specified for the frequency source setting (A001).

Chapter 9 Error Codes

9.4 Other Display for Digital operator

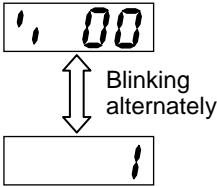
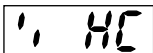
The other display for Digital operator is follows.
It is not displayed with the standard panel.

Name	Description	Display on digital operator
Reset	RS input is ON or STOP/RESET key is pressed.	Rotating 
Waiting in undervoltage status	If the input voltage falls, the inverter will shut off its output, display the code shown on the right, and wait for the recovery of the input voltage. The inverter will display the same error code also during an instantaneous power failure. (remark) Inverter trips with under voltage when this status continues for 40 seconds.	
Waiting for retry	When the retry after instantaneous power failure or tripping has been enabled, the inverter displays the code shown on the right while awaiting retry after an instantaneous power failure or tripping.	
Power-off	The inverter displays the code shown on the right when the inverter power is turned off.	
Restricted operation command	When an operation direction has been restricted by the setting of "b035", the inverter will display the code shown on the right if the operation command specifying the restricted operation direction is input.	
During Initialization for the parameter	Display during initialization for the parameter. In case of the b085=0 (pattern 0)	
	Display during initialization for the parameter. In case of the b085=1 (pattern 1)	
During Initialization for trip history	Display during initialization for the trip history.	
Empty trip history	If the inverter has not tripped before, the inverter displays.	
Communication error	If a problem occurs in the communication between the digital operator and inverter, the inverter will display the code shown on the right.	Blinking 

Chapter 10 Troubleshooting

This chapter describes the troubleshooting methods.

Troubleshooting Tips

The table below lists typical symptoms and the corresponding solution(s).

1. Inverter does not power up.

Possible Cause(s)	Corrective Action
Power cable is incorrectly wired.	Check input wiring
Short bar or DCL between [P] and [PD] is disconnected.	Install short bar or DCL between [P] and [PD] terminal.
Power cable is breaking.	Check input wiring.
Do not apply a normal voltage to terminal L1 and N terminal (single phase), R, S and T terminal (three-phase circuit) to supply power to.	Apply a normal voltage to terminal L1 and N terminal (single phase), R, S and T terminal (three-phase circuit) to supply power to.

2. Motor does not start.

Possible Cause(s)	Corrective Action
Incorrect RUN command source is selected.	Check RUN command source (A002) for correct source. Ex. Terminal (digital input) : 01 Operator (RUN key) : 02
Incorrect frequency source is selected.	Check frequency source (A001) for correct source. Ex. Terminal (analog input) : 01 Operator (F001) : 02
Frequency setting is 0Hz.	If frequency source is terminal (A001=01), check analog voltage or current signal at [O/OI] terminals. If frequency source is operator (A001=02), set frequency in F001. Depending on frequency source, input proper frequency reference. If frequency source is multi-speed operation, set frequency in A020 to A027 and A220.
RUN command is not set to input terminal.	If RUN command source is terminal (A002=01), set "forward" (00:FW) or "reverse" (01:RV) to any input terminals. In case of 3-wire control, set "3-wire start" (20:STA), "3-wire stop" (21:STP) and "3-wire FW/RV" (22:F/R) to any input terminals.
"Multi-speed input(s) (02 to 04:CF1 to CF3)" is (are) set to input terminal(s) and active.	Deactivate the input(s).
Both FWD and REV input are active.	If RUN command source is FWD/REV input, activate either FWD or REV input.
Rotation direction restriction (b035) is enabled.	Check b035.
Incorrect input wiring or short bar position	Wire inputs correctly and/or install short bar. (ON/OFF status of inputs are monitored in d005.)
Incorrect analog input or variable resistor wiring	Wire correctly. In case of analog voltage or variable resistor input, check voltage between [O/OI] and [L] terminal. In case of analog current, check current between current source and [O/OI] terminal.
RUN command source is operator, but input terminal is set to "Force terminal" and active.	Deactivate the input.
RUN command source is terminal, but input terminal is set to "Force operator" and active.	Deactivate the input.
Inverter is in trip status. (With ALARM LED and "Exxx" indication)	Reset inverter by STOP/RESET key and check error code or Power OFF the inverter.
"18:RS" or "11:FRS" is set to input terminal and the input is active.	Deactivate the input.
"84:ROK" is set to input terminal and the input is active.	Activate the input.
Cable between inverter and motor or internal cable of motor is breaking.	Check the wiring.
Excessive load.	Remove excessive load.
Motor is locked.	Unlock the motor.

Chapter 10 Troubleshooting

3. Motor does not accelerate to command speed.

Possible Cause(s)	Corrective Action
Bad connection of analog wiring.	Check the wiring. In case of analog voltage or variable resistor input, check voltage between [O/OI] and [L] terminal. In case of analog current, check current between current source and [O/OI] terminal. Check SW6. Once again, set the SW6 ON-OFF
Overload restriction or OC suppression function works.	Check the function level.
Max. frequency (A004) or upper limit (A061/A261) is lower than as expected.	Check the value.
Acceleration time is excessive.	Change acceleration time (F002/A092/A292).
"Multi-speed input(s) (02 to 04:CF1 to CF3)" is (are) set to input terminal(s) and active.	Deactivate the input(s).
"06:JG " is set to input terminal and the input is active.	Deactivate the input.
Excessive load.	Remove excessive load.
Motor is locked.	Unlock the motor.

4. Inverter does not respond to changes in frequency setting F001 display from operator.

Possible Cause(s)	Corrective Action
Incorrect frequency source is selected.	Check frequency source (A001=02).
"51:F-TM" is set to input terminal and the input is active.	Deactivate the input.

5. A part of function codes is not displayed.

Possible Cause(s)	Corrective Action
"Function code display restriction" (b037) is enabled.	Set 00 (all display) to b037.
"86:DISP" is set to input terminal and the input is active.	Deactivate the input.

6. Operator (keypad) does not respond.

Possible Cause(s)	Corrective Action
"86:DISP" is set to input terminal and the input is active.	Deactivate the input.

7. Parameter data does not change.

Possible Cause(s)	Corrective Action
Inverter is in RUN status.	Stop the inverter, make sure the motor stops and try again. If "RUN mode edit" is enabled, a part of function codes can be changed in RUN status.
Software lock function (b031) is enabled.	Disable software lock function.

8. Motor rotates reverse direction with forward command.

Possible Cause(s)	Corrective Action
Incorrect power wiring.	Exchange any two of U/T1, V/T2 or W/T3.
Incorrect logic of direction signal in 3-wire operation.	Check the logic of input set as "22:F/R".

9. Motor rotates reverse direction with RUN key of keypad.

Possible Cause(s)	Corrective Action
Keypad RUN key routing (F004) is incorrectly set.	Check F004.

10. .Overcurrent trip (E03)

Possible Cause(s)	Corrective Action
Acceleration time is short.	Change acceleration time (F002/A092/A292). Enable "acceleration hold" function (A069,A070)
Excess load.	Remove excess load. Enable torque boost function. Set free V/f in V/F characteristic curve selection (A044/A244=02)
Overload restriction (b021) is disabled (00).	Enable overload restriction (b021=01/02).
When the inverter trips due to Overcurrent(E03), despite overload restriction is enabled(b021=01/02).	
Overload restriction level (b022/b025) is high.	Set overload restriction level (b022/b025) lower.
Deceleration rate at overload restriction (b023/b026) is too short.	Set deceleration rate at overload restriction (b023/b026) longer.

11. STOP/RESET key does not respond.

Possible Cause(s)	Corrective Action
STOP/RESET key disabled.	Check "STOP key enable" function. (b087)
Deceleration overvoltage suppression (b130) or controlled deceleration on power loss (b050) function is enabled.	Check b130 and b050.

12. Sound noise of motor or machine.

Possible Cause(s)	Corrective Action
Carrier frequency is low.	Set carrier frequency (b083) higher. (This could cause electric noise and leak current higher.)
Machine frequency and motor frequency are resonated.	Change output frequency slightly. If resonating in accel/deceleration, use jump frequency function (A063-68) to avoid machine frequency.
Over excitation	Set base frequency (A003/A203) and AVR voltage (A082/A282) according to motor rating. If not improved, reduce V/f gain (A045/A245) slightly or change V/f curve (A044/A244) as free V/f.

13. Overload trip (E05).

Possible Cause(s)	Corrective Action
Improper electronic thermal level	Check electronic thermal setting (b012/b013)

14. Over voltage trip (E07).

Possible Cause(s)	Corrective Action
Short deceleration time	Change deceleration time. (F003/F203/A093/A293)
Overvoltage suppression during deceleration (b130) is disabled (00).	Enable overvoltage suppression (b130=01/02).

When the inverter trips due to over voltage, despite over voltage suppression is enabled.

Improper overvoltage suppression propotional gain (b134) or integral time (135).	Check overvoltage suppression proportional gain (b134) and integral time (b135).
Overvoltage suppression level (b131) is high.	Set Overvoltage suppression level (b131) lower. (Lower limit of parameter b131 must be (input voltage) × $\sqrt{2}$ × 1.1.)

15. Unstable output frequency.

Possible Cause(s)	Corrective Action
Improper parameters	Set output frequency slightly smaller or bigger value than power source frequency. Change motor stabilization constant (H006/H206). Reduce carrier frequency (b083). Reduce V-Gain (A045).
Load variation is excessive.	Change motor and inverter to one size bigger.
Power voltage variation is excessive.	Check power source.

Chapter 10 Troubleshooting

16. Output torque is not sufficient.

Possible Cause(s)	Corrective Action
Improper parameters [Acceleration]	Increase torque boost (A042/A242-A043/A243)
	Reduce carrier frequency (b083).
	Change torque boost select (A041/A241) to automatic.
Improper parameters [Deceleration]	Increase deceleration time (F003/F203/A093/A293).
	Disable AVR function (A081/A281).

17. If cable to operator is disconnected, inverter will trip or stop.

Possible Cause(s)	Corrective Action
Improper setting of b165.	Set ex.operator com loss action (b165) to 02.

18. No response over Modbus communication.

Possible Cause(s)	Corrective Action
New parameter is not updated.	If C070, C071, C074 or C075 is changed, cycle power or reset inverter by turning RS terminal ON and OFF.
Incorrect setting of RUN command source (A002/A202).	Set RUN command source (A002/A202) to 03.
Incorrect setting of Frequency source (A001/A201).	Set frequency source (A001/A201) to 03.
Incorrect setting of com. speed.	Check communication speed (C071).
Incorrect setting or duplication of Modbus address.	Check Modbus address (C072).
Incorrect setting of com. parity.	Check communication parity (C074).
Incorrect setting of com. stop bit.	Check communication stop bit (C075).
Incorrect wiring.	Check communication wiring at SP,SN .

19. When inverter starts, ECB (Earth leakage Circuit Breaker) trips.

Possible Cause(s)	Corrective Action
Leak current of inverter is excessive.	Reduce carrier frequency (A083).
	Increase current sensor level of ECB or replace ECB with another one having higher current sensor level.

20. DC braking doesn't work

Possible Cause(s)	Corrective Action
DC braking force for deceleration (A054) isn't set. (Defaults (0.))	Set DC braking force for deceleration (A054).
DC braking time for deceleration (A055) isn't set. (Defaults (0.0))	Set DC braking time for deceleration (A055).

21. Under-voltage error

Possible Cause(s)	Corrective Action
Decrease in input voltage due to capacity shortage of electric source.	Make capacity of electric source larger.

22. TV or radio near inverter receives noises

Possible Cause(s)	Corrective Action
The radiation noise generated by the inverter.	Put away those devices from the inverter as far as possible.

23. Remote operator becomes a communication error.

Possible Cause(s)	Corrective Action
Poor contact of the cables and connectors. Disconnection of cable.	Reconnect the cable. Replace the cable.
SW5 has become RS485 side.	SW5 sets operator side.
Selection of OPE/Modbus(C070) has become "01(Modbus)".	Turn on the power while pressing the [RUN/STOP/RESET] key. Key you press and hold for about 5 seconds after power is turned on. Selection of OPE/Modbus(C070) sets "00(OPE)". Please on the power again after power-off.

24. NES1-OP does not appear. NES1-OP display is abnormal.

Possible Cause(s)	Corrective Action
Poor contact of the inverter connector and NES1-OP.	Please reconnect the NES1-OP after power-off.

25. Output phase loss protection(E34) is occur.

Possible Cause(s)	Corrective Action
Motor cable is disconnected or not connected.	Check the wiring.
Motor current is small.	Out phase loss set(C157) sets 00(disable).

Chapter 11 Maintenance and Inspection

This chapter describes the precautions and procedures for the maintenance and inspection of the inverter.

11.1	Precautions for Maintenance and Inspection.....	11 - 1
11.2	Daily and Periodic Inspections	11 - 2
11.3	Ground Resistance Test with a Megger	11 - 3
11.4	Withstand Voltage Test	11 - 3
11.5	Methods of Measuring the Input/Output Voltages, Current, and Power	11 - 4
11.6	Capacitor Life Curves.....	11 - 5

11.1 Precautions for Maintenance and Inspection



- Before inspecting the inverter, be sure to turn off the power supply and wait for 10 minutes or more. Otherwise, you run the risk of electric shock.
(Before inspection, confirm that the Charge lamp on the inverter is off.)
In case the power indication of the operator does not turn ON after power-up, inverter may be damaged. In that case, the inspection must be done after waiting 2 hours or more of the power OFF. Otherwise there is a danger of electric shock and/or injury.
- Commit only a designated person to maintenance, inspection, and the replacement of parts.
(Be sure to remove wristwatches and metal accessories, e.g., bracelets, before maintenance and inspection work and to use insulated tools for the work.) Otherwise, you run the risk of electric shock and injury.
- Never modify the inverter. Otherwise, you run the risk of electric shock and injury.

(A) Daily inspection

Basically check your system during the inverter operation to confirm that:

- 1) the motor is operating according to the settings on the inverter,
- 2) the installation environment is normal,
- 3) the cooling system is normal,
- 4) no abnormal vibrations and noise are generated,
- 5) no equipment overheating and discoloration are found, and
- 6) there are no unusual smells.

While the inverter is operating, measure the inverter input power voltage with a multimeter to confirm that:

- 1) the power supply voltage does not fluctuate often
- 2) the voltages between the power supply wires are balanced.

(B) Cleaning

Always keep the inverter clean. When cleaning the inverter, wipe off dirt and stains on the inverter surface lightly with a soft cloth dipped in a neutral detergent solution.

Note:

Do not use solvents such as acetone, benzene, toluene, and alcohol for cleaning. These solvents cause the inverter surface to dissolve or the coating on the surface to peel off. In particular, never use a detergent or alcohol to clean the monitor of the digital operator.

(C) Periodic inspection

Check those inverter sections and parts which are accessible only while the inverter is power off and which should be inspected regularly. When you intend to carry out a periodic inspection, contact your local Hitachi Distributor.

During a periodic inspection, perform the following:

- 1) Check that the cooling system is normal. Clean the air filter as needed.
- 2) Check the screws and bolts for tightness, and retighten them. Screws and bolts may have loosened because of vibrations and temperature changes. Check them carefully.
- 3) Check to ensure conductors and insulators are not corroded or damaged.
- 4) Measure the dielectric breakdown voltage of insulators.
- 5) Check the cooling fan, smoothing capacitors, and relays, and replace them if necessary.

Chapter 11 Maintenance and Inspection

11.2 Daily and Periodic Inspections

Item Inspected		Check for...	Inspection Cycle		Inspection Method	Criteria
			Daily	Year		
Overall	Ambient environment	Extreme temperatures & humidity	✓		Thermometer, hygrometer	Ambient temperature between -10 to 50°C, Humidity 90% or less non-condensing
	Major devices	Abnormal noise & vib.	✓		Visual and aural	Stable environment for electronic controls
	Power supply voltage	Voltage tolerance	✓		Digital volt meter, measure between inverter terminals [L1], [L2], [L3]	200V class: 50/60 Hz 200 to 240V (-15/+10%) 400V class: 50/60 Hz 380 to 480V (-15/+10%)
Main circuit	Ground Insulation	Adequate resistance		✓	Refer to P6-16	5 MΩ or greater
	Ground terminal	No loose screws		✓	Torque wrench	M4: 0.8Nm
	Components	Overheating		✓	Thermal trip events	No trip events
	Terminal block	Secure connections		✓	Visual	No abnormalities
		No loose screws		✓	Torque wrench	M3.5: 1.0Nm M4: 1.5Nm
	Smoothing capacitors	Leaking, swelling		✓	Visual	No abnormalities
	Relay(s)	Chattering		✓	Aural	Single click when switching ON or OFF
Resistors	Cracks or discoloring		✓	Visual	Check Ohms of optional braking res.	
Control circuit	Function	Voltage balance between phases		✓	Measure voltage between U,V,W	Difference must be 2% or less.
		Protection circuit		✓	e.g. Input Ex.trip signal and check inverter behavior and alarm signal.	Functions properly.
	Overall	No odor, discoloring, corrosion		✓	Visual	No abnormalities
	Capacitor	Leaking, swelling		✓	Visual	Undistorted appearance
	Terminal	No loose screws		✓	Torque wrench	M2: 0.2Nm
Cooling	Cooling fan	Noise	✓		Power down, manually rotate	Rotation must be smooth
		Dust		✓	Visual	Vacuum to clean
		Mounting		✓	Visual	Mounted firmly
	Heat sink	Dust		✓	Visual	Vacuum to clean
Display	LEDs	Legibility	✓		Visual	All LED segments work

Note 1: The life of a capacitor is affected by the ambient temperature. See “11.6”.

Note 2: Designed life of a cooling fan is 10 years. However, it is affected by the ambient temperature and other environmental conditions.

Note 3: The inverter must be cleaned periodically. If dust accumulates on the fan and heat sink, it can cause overheating of the inverter.

Note 4: Do not pull the cooling FAN's wire, otherwise cooling FAN might cut the wires and cause failure.

11.3 Ground Resistance Test with a Megger

When testing an external circuit with a megger, disconnect all the external circuit cables from the inverter to prevent it from being exposed to the test voltage.

Use a tester (in high-resistance range mode) for a conduction test on the control circuit. Do not use a megger or buzzer for that purpose.

Apply the ground resistance test using a megger only to the main circuit of the inverter. Do not carry out the test using a megger for its control circuit.

Use a 500 VDC megger for the ground resistance test.

Before the main circuit test with a megger, and then connect terminals R/L1, S/L2, T/L3, U/T1, V/T2, W/T3, P/+ and PD/+1 by wires as shown in the figure below. Subsequently, carry out the test.

After the test using the megger, remove the wires from terminals R/L1, S/L2, T/L3, U/T1, V/T2, W/T3, P/+ and PD/+1. (Single phase input model is R/L1, S/L2, T/L3, U/T1, V/T2, W/T3, P/+ and PD/+1)

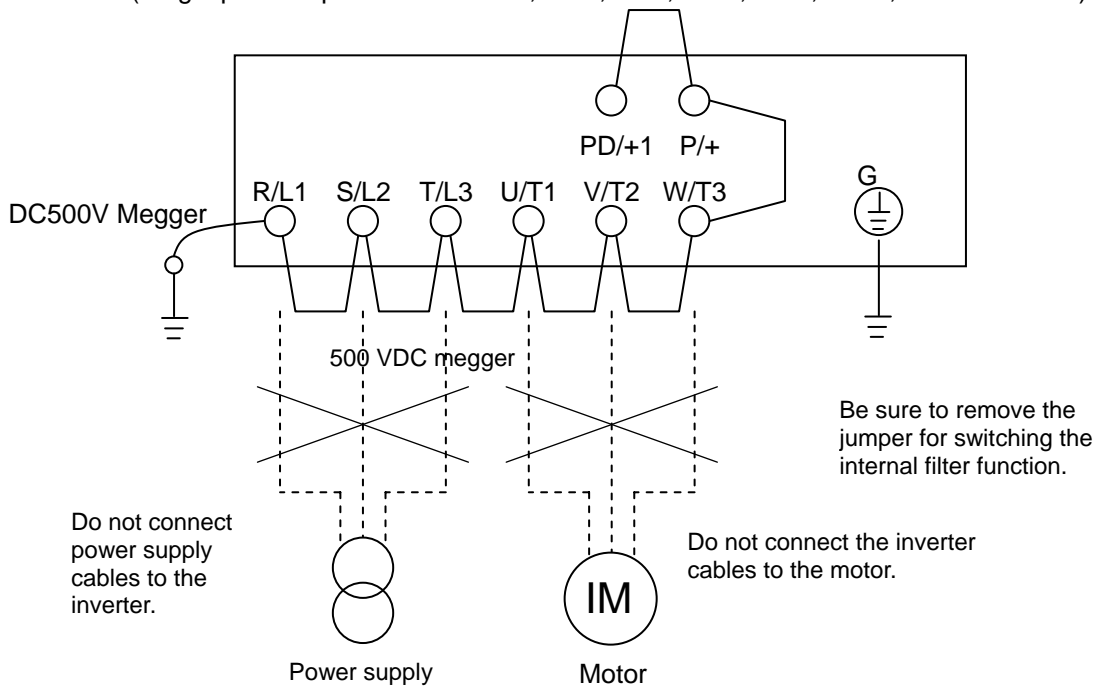

11.4 Withstand Voltage Test

Do not carry out a withstand voltage test for the inverter. The test may damage its internal parts or cause them to deteriorate.

Chapter 11 Maintenance and Inspection

11.5 Methods of Measuring the Input/Output Voltages, Current, and Power

This section describes the measuring instruments generally used to measure the input and output voltages, output current, and output power of the inverter.

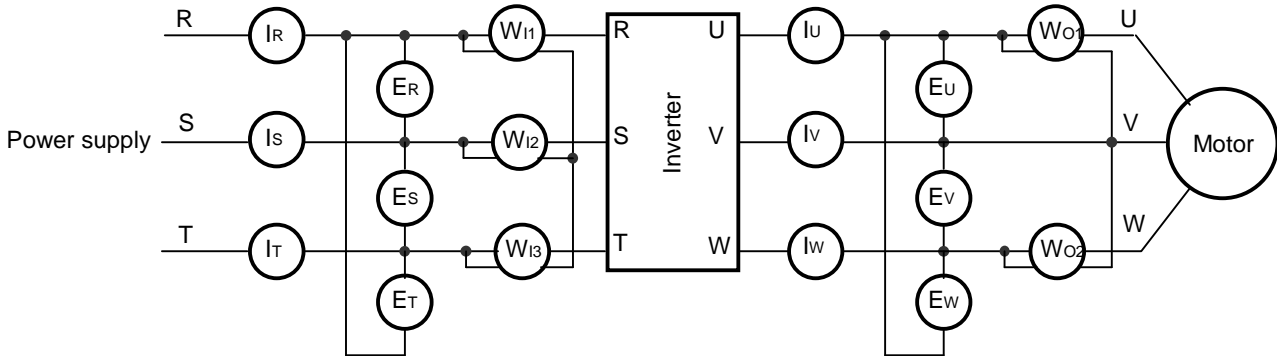

Measurement item	Measuring point	Measuring instrument	Remarks	Reference values
Input voltage (E_{IN})	Across R-S, S-T, and T-R (E_R , (E_S), and (E_T))	Moving-iron voltmeter or rectifier-type voltmeter	Effective value of full waves	200 V class models: 200 to 240 V, 50/60 Hz 400 V class 380 to 480 V, 50/60 Hz
Input current (I_{IN})	Current at R, S, and T (I_R , (I_S), and (I_T))	Moving-iron ammeter	Effective value of full waves	When input currents are unbalanced $I_{IN} = (I_R + I_S + I_T)/3$
Input power (W_{IN})	Across R-S, S-T, and T-R (W_{11}) + (W_{12}) + (W_{13})	Electro-dynamometer-type wattmeter	Effective value of full waves	3-wattmeter method
input power factor (Pf_{IN})	Calculated from the measured input voltage (E_{IN}), input current (I_{IN}), and input power (W_{IN}) $Pf_{IN} = \frac{W_{IN}}{\sqrt{3} \cdot E_{IN} \cdot I_{IN}} \times 100 (\%)$			
Output voltage (E_{OUT})	Across U-V, V-W, and W-U (E_U), (E_V), and (E_W))	Method shown in the figure below or rectifier-type voltmeter	Effective value of fundamental wave	
Output current (I_{OUT})	Current at U, V, and W (I_U), (I_V), and (I_W))	Moving-iron ammeter	Effective value of full waves	
Output power (W_{OUT})	Across U-V and V-W (W_{01}) + (W_{02})	Electro-dynamometer-type wattmeter	Effective value of full waves	2-wattmeter method (or 3-wattmeter method)
Output power factor (Pf_{OUT})	Calculated from the measured input voltage (E_{OUT}), input current (I_{OUT}), and input power (W_{OUT}) $Pf_{OUT} = \frac{W_{OUT}}{\sqrt{3} \cdot E_{OUT} \cdot I_{OUT}} \times 100 (\%)$			

Notes:

- To measure the output voltage, use an instrument that reads the effective value of the fundamental wave. To measure the current or power, use an instrument that reads the effective value of full waves.
- Since the inverter output waveform is controlled by PWM, it has a large margin of error, especially at low frequencies. In many cases, general testers may be inapplicable for the measurement because of the adverse effect of noise.

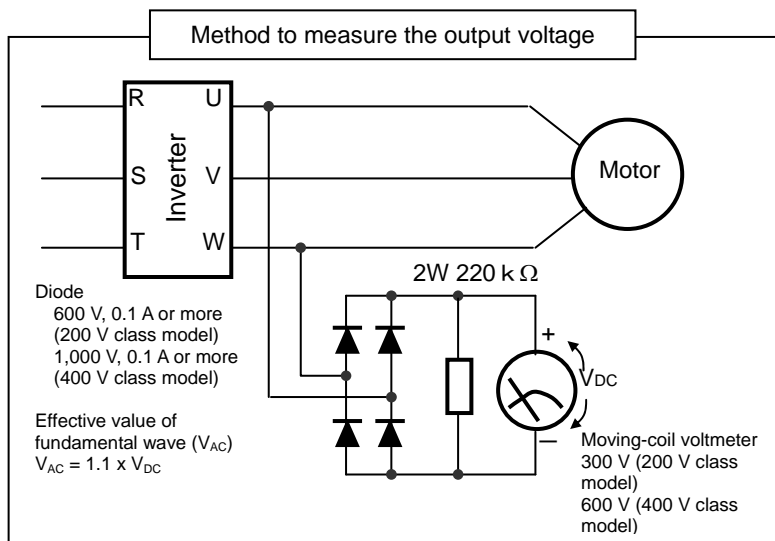

11.6 Capacitor Life Curves

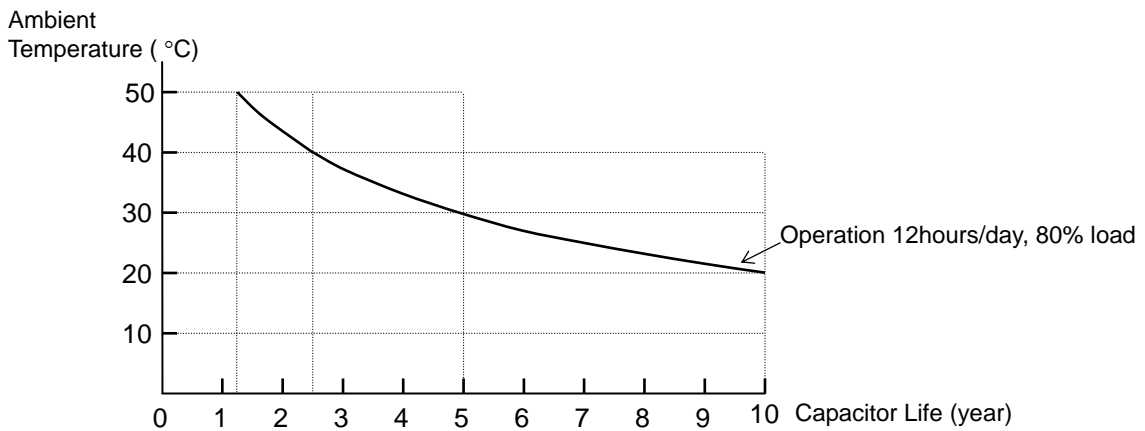

Capacitor Life

- Note 1: The ambient temperature indicates the temperature measured at a position about 5 cm distant from the bottom center of the inverter body. If the inverter is mounted in an enclosure, the ambient temperature is the temperature within the enclosure.
- Note 2: Inverter has a limited life because chemical reactions occur inside the capacitor during operation. The capacitor Life is the above curve. (The curve is not the guaranteed lifespan but rather, the expected design lifespan.)
 Note that the smoothing capacitor life will be shortened significantly if the inverter is used at a high ambient temperature or with a heavy load that requires a current beyond its rated current.

Warranty

Warranty Terms

The warranty period under normal installation and handling conditions shall be two (2) years from the date of manufacture, or one (1) year from the date of installation, whichever occurs first. The warranty shall cover the repair or replacement, at Hitachi's sole discretion, of ONLY the inverter that was installed.

1. Service in the following cases, even within the warranty period, shall be charged to the purchaser:
 - a. Malfunction or damage caused by mis-operation or modification or improper repair
 - b. Malfunction or damage caused by a drop after purchase and transportation
 - c. Malfunction or damage caused by fire, earthquake, flood, lightning, abnormal input voltage, contamination, or other natural disasters
2. When service is required for the product at your work site, all expenses associated with field repair shall be charged to the purchaser.
3. Always keep this QRG handy; please do not lose it. Please contact your Hitachi distributor to purchase replacement or additional manuals.

Chapter 12 Specifications



This chapter describes the specifications and external dimensions of the inverter.

12.1 Specifications	12-1
12.2 Dimensions.....	12-3
12.3 Derating Curves	12-5

12.1 Specifications

200V Class

Item		Three-phase 200V class Specifications					Single-phase 200V class Specifications				
NES1 inverters, 200V models Note8)		002L*	004L*	007L*	015L*	022L*	002S*	004S*	007S*	015S*	022S*
Applicable motor size Note1)	kW	0.2	0.4	0.75	1.5	2.2	0.2	0.4	0.75	1.5	2.2
	HP	1/4	1/2	1	2	3	1/4	1/2	1	2	3
Rated capacity (kVA)	200V	0.4	0.9	1.3	2.4	3.4	0.4	0.9	1.3	2.4	3.4
	240V	0.5	1.0	1.6	2.9	4.1	0.5	1.0	1.6	2.9	4.1
Rated input voltage		Three-phase: 200V-15% to 240V +10%, 50/60Hz ±5%					Single-phase: 200V-15% to 240V +10%, 50/60Hz ±5%				
Rated output voltage Note2)		3-phase: 200 to 240V (proportional to input voltage)									
Rated output current (A)		1.4	2.6	4.0	7.1	10.0	1.4	2.6	4.0	7.1	10.0
Cooling method		Self-cooling			Force ventilation		Self-cooling			Force ventilation	
Braking (capacitive feedback) Note3)		Apprx.50%			Apprx.20 to 40%		Apprx.50%			Apprx.20 to 40%	
Weight	(kg)	0.7	0.8	0.9	1.2	1.3	0.7	0.8	1.0	1.2	1.3
	(lb)	1.6	1.8	2.0	2.7	2.9	1.6	1.8	2.2	2.7	2.9

400V Class

Item		Three-phase 400V class Specifications				
NES1 inverters, 400V models Note8)		004H*	007H*	015H*	022H*	040H*
Applicable motor size Note1)	kW	0.4	0.75	1.5	2.2	4.0
	HP	1/2	1	2	3	5
Rated capacity (kVA)	380V	0.9	1.6	2.6	3.6	6.0
	480V	1.2	2.0	3.4	4.5	7.6
Rated input voltage		Three-phase: 400V-15% to 480V +10%, 50/60Hz ±5%				
Rated output voltage Note2)		3-phase: 380 to 480V (proportional to input voltage)				
Rated output current (A)		1.5	2.5	4.1	5.5	9.2
Cooling method		Self-cooling	Force ventilation			
Braking (capacitive feedback) Note3)		Apprx.50%		Apprx.20 to 40%		
Weight	(kg)	0.9	0.9	1.0	1.1	1.2
	(lb)	2.0	2.0	2.2	2.4	2.7

Chapter 12 Specifications

Common specification

Item		Spec
Protective housing (JIS C 0920, IEC60529)		IP20
Control	Control method	Sinusoidal Pulse Width Modulation (PWM) control
	Output frequency range Note4)	0.1 to 400 Hz
	Frequency accuracy Note5)	Digital command: $\pm 0.01\%$ of the maximum frequency Analog command: $\pm 0.4\%$ of the maximum frequency ($25^{\circ}\text{C} \pm 10^{\circ}\text{C}$)
	Frequency setting resolution	Digital input: 0.01 Hz Analog input: Maximum output frequency/1000
	Volt./Freq. characteristic	V/f control (constant torque, reduced torque)
	Overload capacity	150%/60 seconds
	Acceleration/deceleration time	0.00 to 3,600.0 seconds (in linear or curved pattern), 2nd motors setting is possible
Input signal	Freq. setting	External signal : adjustable resistor / 0 to +10 VDC / 0 to 20 mA, Modbus, Option operator, Dedicated operator
	RUN/STOP Order	External digital input signal (3-wire input possible) , Modbus Option Operator, Dedicated Operator
	Intelligent input terminal	5terminals
	Analog input	1terminal (O/OI terminal : Voltage input10bit/0 to 10V, Current input : 10bit/0 to 20mA selecting it with a changeover switch)
Output signal	Intelligent output terminal	5 open-collector output terminals, 1 relay (1c-contact) output terminal
	Pulse Output	1terminal
connection	RS-422	RJ45 Connector ,(Common with RS485 : selecting it with a changeover switch) Option Operator, ProDriveNext
	RS-485	RJ45 Connector ,(Common with RS422 : selecting it with a changeover switch) Modbus-RTU
General specification	Temperature Note6)	Operating (ambient): -10 to 50°C , / Storage: -20 to 65°C
	Humidity	20 to 90% humidity (non-condensing)
	Vibration	5.9m/s^2 (0.6G), 10 to 55 Hz
	Location	Altitude 1,000m or less, indoors (no corrosive gasses or dust)
	Standards Compliance	UL、CE、c-UL、c-tick

- Note1) The applicable motor refers to Hitachi standard 3-phase motor (4p). When using other motors, care must be taken to prevent the rated motor current (50/60Hz) from exceeding the rated output current of the inverter.
- Note2) The output voltage decreases as the main supply voltage decreases (except when using the AVR function). In any case, the output voltage cannot exceed the input power supply voltage.
- Note3) The braking torque via capacitive feedback is the average deceleration torque at the shortest deceleration (stopping from 50/60Hz as indicated). It is not continuous regenerative braking torque. The average deceleration torque varies with motor loss. This value decreases when operating beyond 50Hz.
- Note4) To operate the motor beyond 50/60Hz, consult the motor manufacturer for the maximum allowable rotation speed.
- Note5) To get motor stabilized operation, inverter output Frequency might exceeds preset maximum Freq.(A004/A204) by 2Hz in maximum.
- Note6) Derating curve is shown on section 12.3.
- Note7) Connecting work on RJ45 jack must be done during the inverter power off.
- Note8) *** changes by Restricted Distribution.

12.2 Dimensions

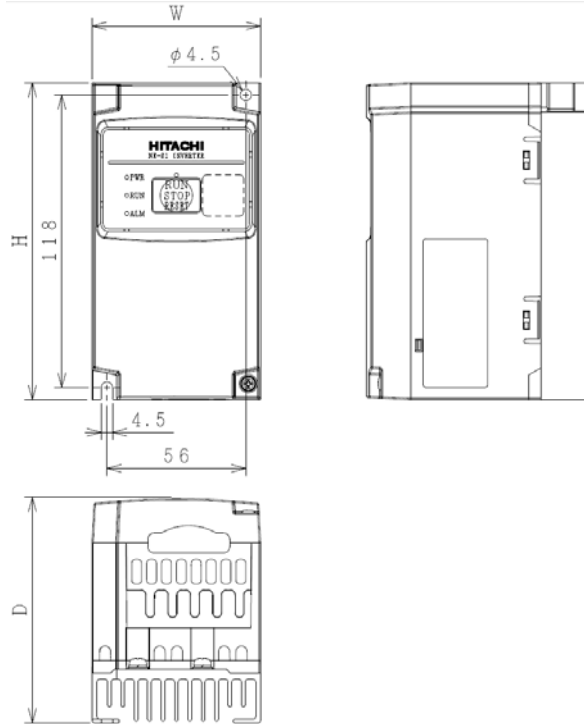

Model Note)	W (mm)	H (mm)	D (mm)	D1 (mm)
NES1-002S*	68	128	76	7
NES1-004S*			91	21.5
NES1-002L*			76	7
NES1-004L*			91	21.5
NES1-007L*			115	46

Note) "*" changes by Restricted Distribution.

Chapter 12 Specifications

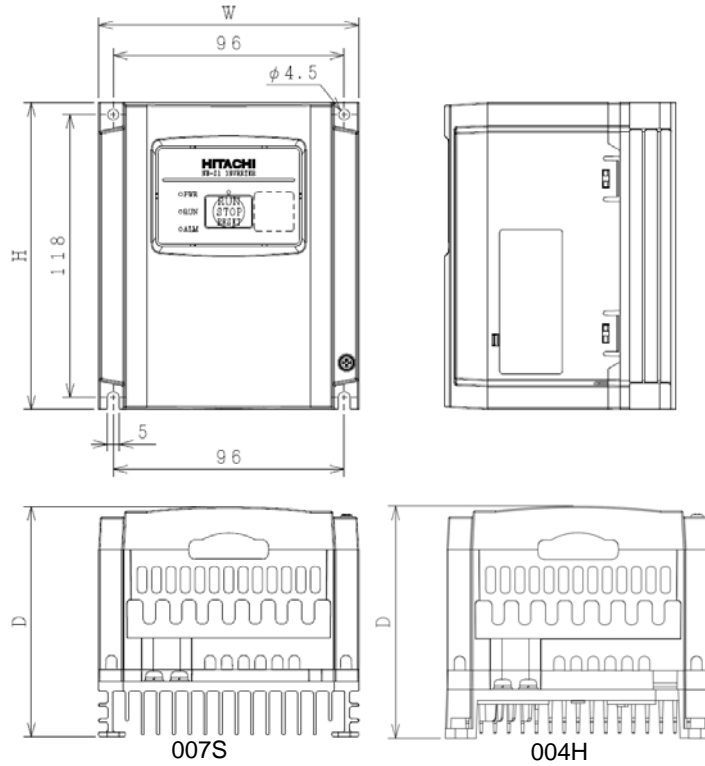

Model Note)	W (mm)	H (mm)	D (mm)
NES1-007S*	108	128	96
NES1-004H*			

Note) "*" changes by Restricted Distribution.

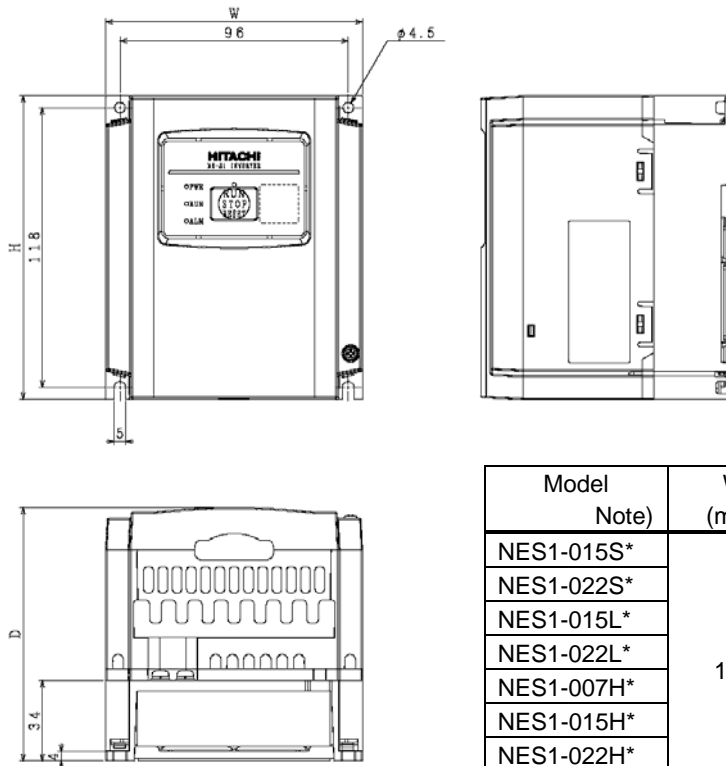

Model Note)	W (mm)	H (mm)	D (mm)
NES1-015S*	108	128	107
NES1-022S*			125
NES1-015L*			107
NES1-022L*			125
NES1-007H*			96
NES1-015H*			111
NES1-022H*			125
NES1-040H*			135

Note) "*" changes by Restricted Distribution.

12.3 Derating Curves

Use the following derating curves to help determine the optimal carrier frequency setting for your inverter and find the output current derating. Be sure to use the proper curve for your particular NE-S1 inverter model number.

Become all the production after August, 2012 when Restricted Distribution is China or Europe.

Legend for Graphs:

- Ambient temperature 30°C max.
- ⋯ Ambient temperature 40°C max.
- · - · Ambient temperature 50°C max.
- Rated output current (A)

Production:after August, 2012

NES1-002LB

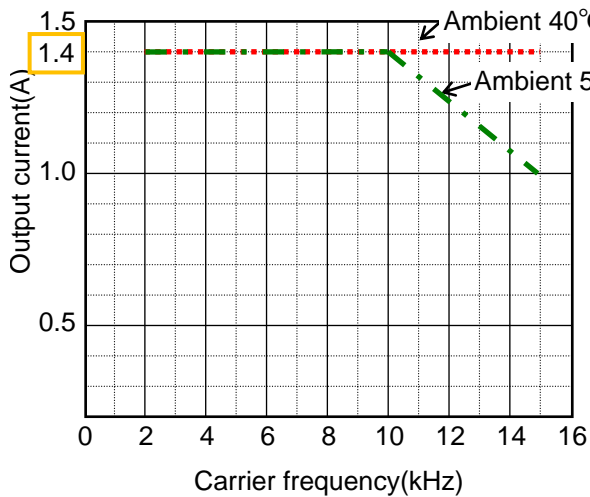

NES1-002SB

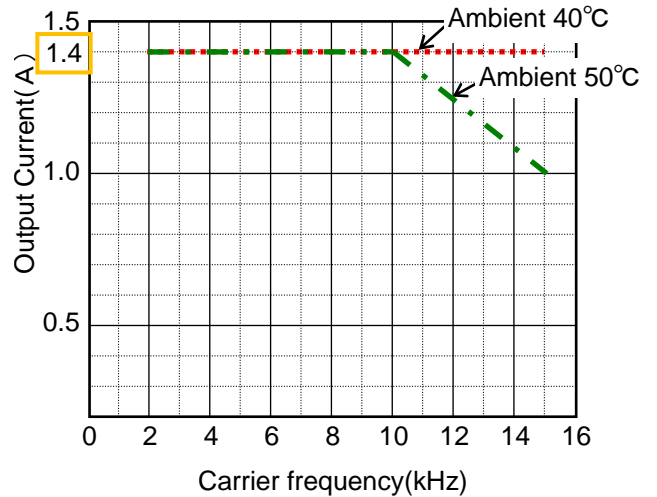

NES1-004LB

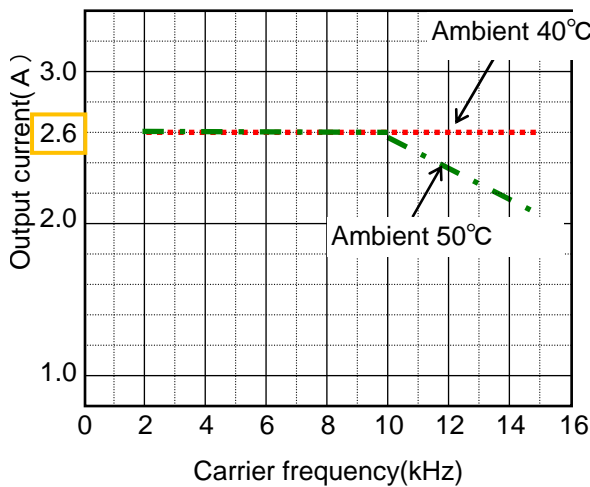

NES1-004SB

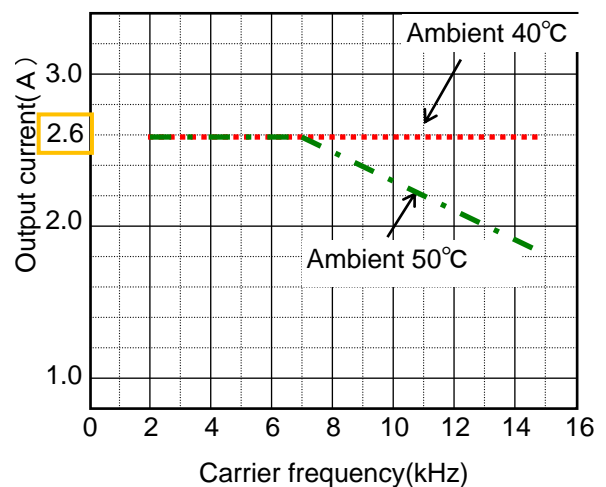

Chapter 12 Specifications

NES1-022LB

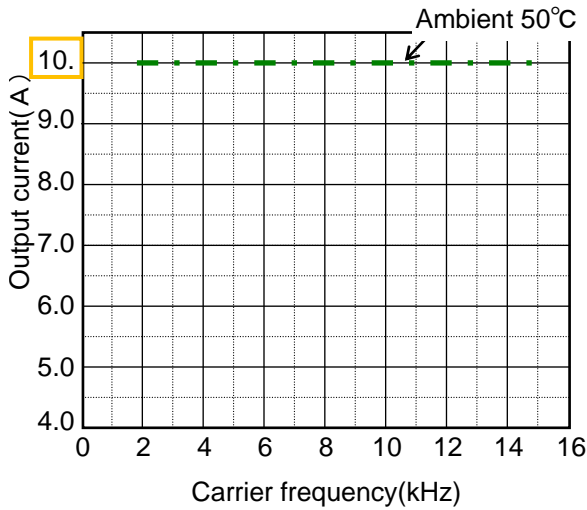

NES1-022SB

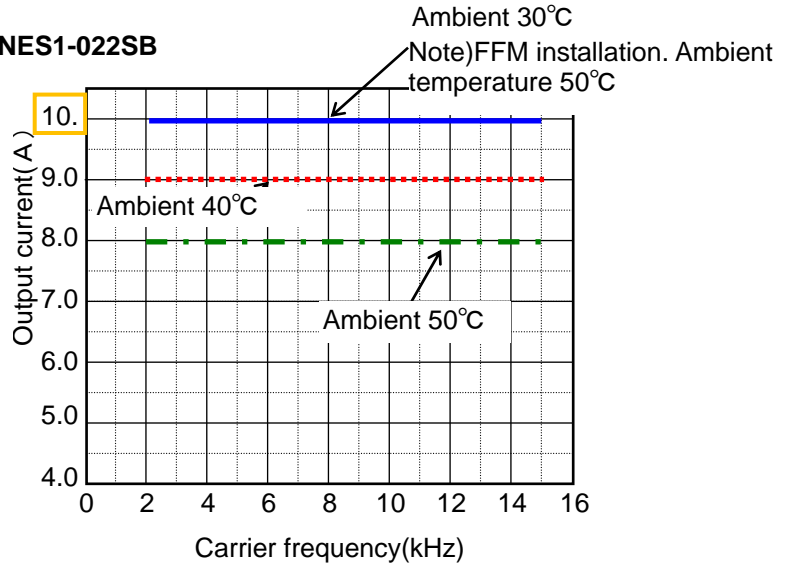

Note) If I attach optional FFM to the inverter, show that it becomes derating-free.

NES1-004HB

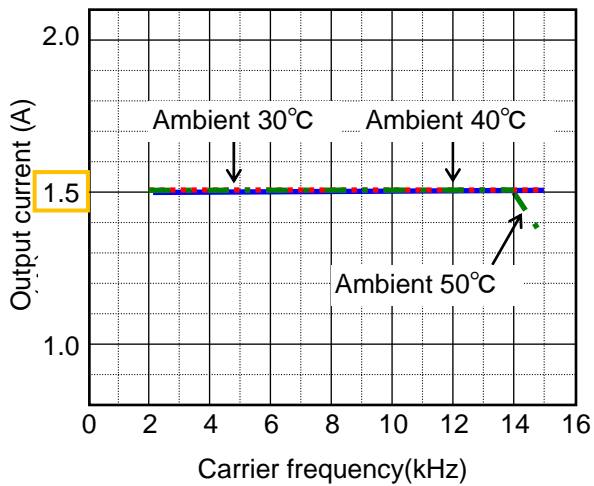

NES1-040HB

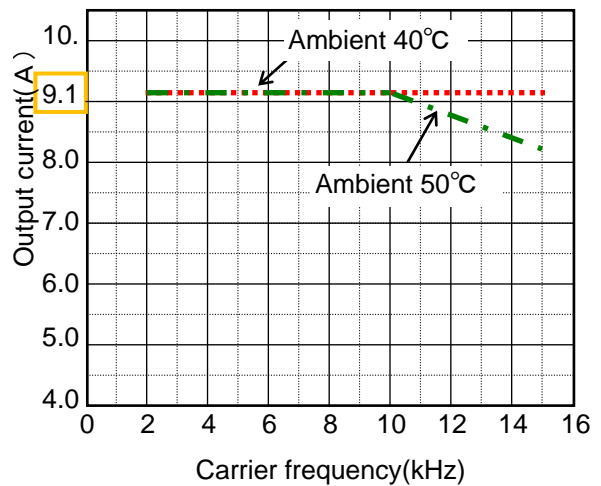

The 400V class series except 004HB is not necessary for the derating.

Production: before July, 2012

NES1-002LB

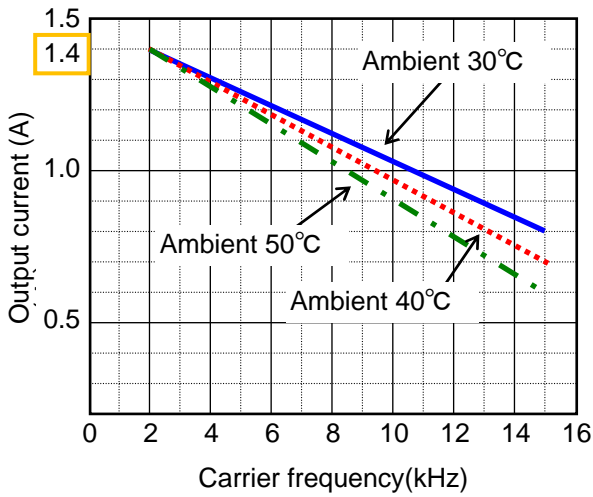

NES1-002SB

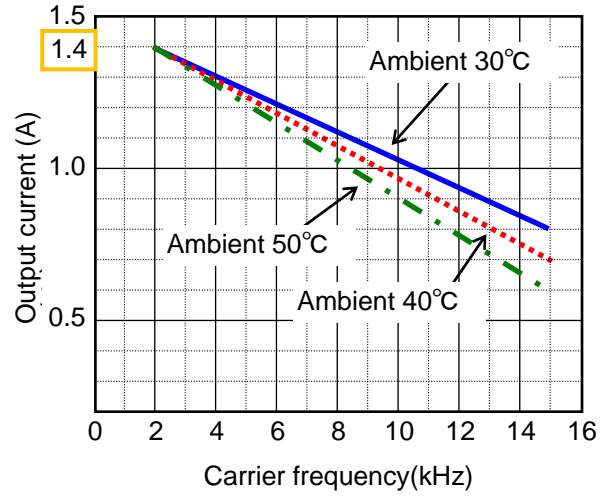

NES1-004LB

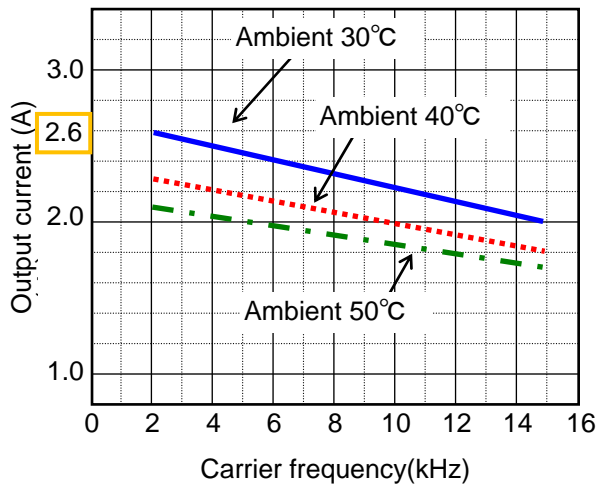

NES1-004SB

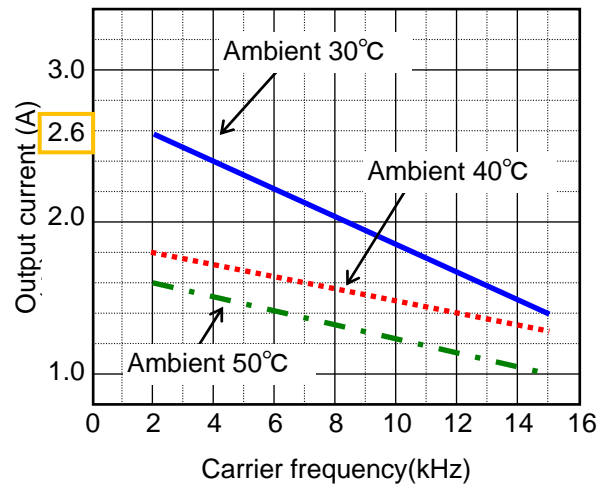

NES1-007LB

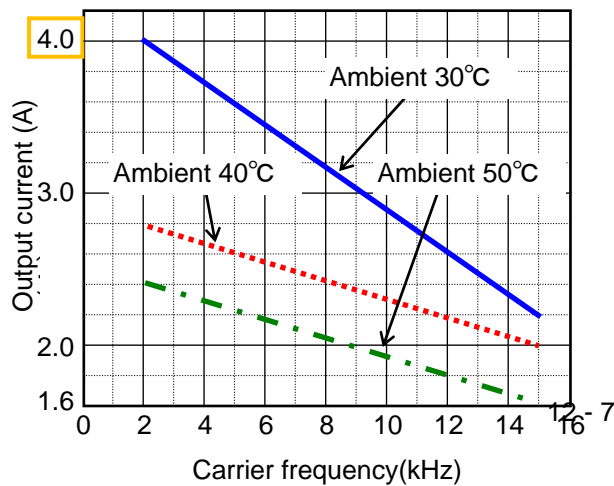

NES1-007SB

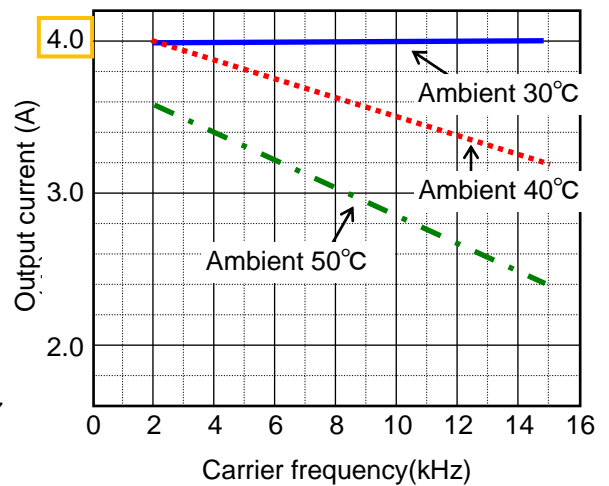

Chapter 12 Specifications

NES1-015LB

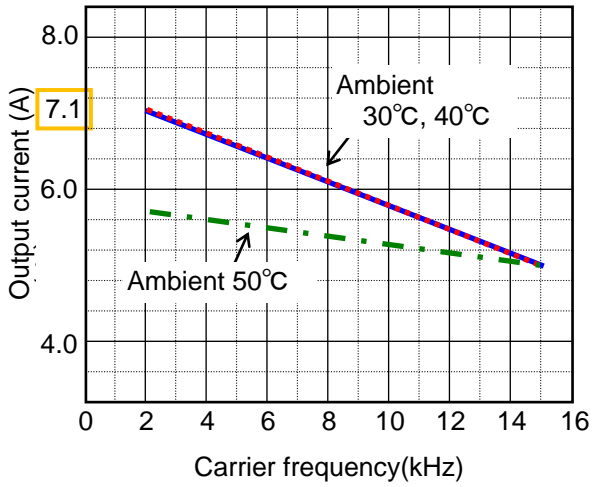

NES1-015SB

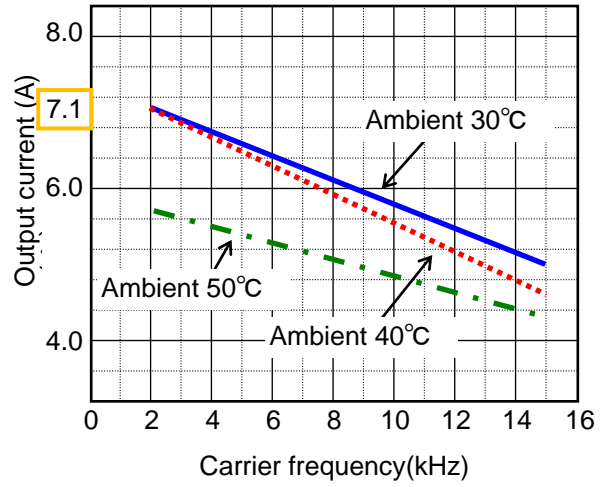

NES1-022LB

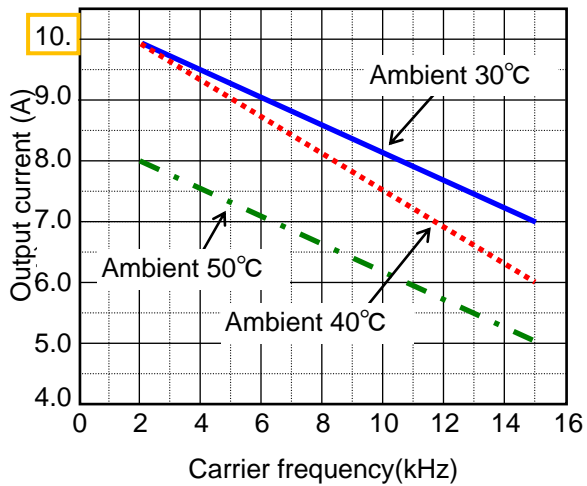

NES1-022SB

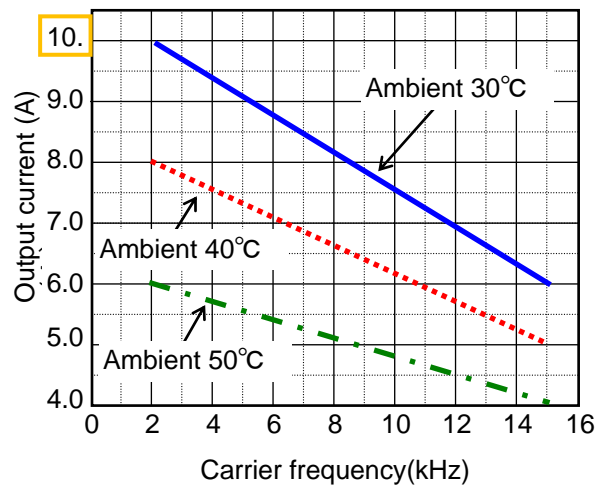

Legend for Graphs:

- Ambient temperature 30°C max.
- ⋯ Ambient temperature 40°C max.
- - - Ambient temperature 50°C max.
- Rated output current (A)

Chapter 13 Option

Illustrate by this chapter about options of NES1.

13.1 Digital Operator



Digital Operator prepares NES1-OP,OPE-S/SR/SBK/SRmini and WOP. NES1-OP can be attached to the NES1 inverter. Other than it, be the connection with the cable.

13.1.1 Attention at the time of the data setting

- When Function code display restriction(b037) are set other than "00" (all indication), some functions are not displayed.
- When Software lock mode selection (b031) is validly set, cannot change the parameter.
- The function of "-" cannot change a column of "Run Mode Edit" while driving.
- It becomes modifiable mode while driving when I establish Software lock mode selection (b031) in "10"

13.1.2 Monitoring mode (Display of NES1-OP,OPE-S/SR/SBK/SRmini)

·The initial state displays (d001) at the time of power activation by all means. When you fix it by any display, please change setting of (b038).

Func. Code	Name	Description	Run Mode Edit	Defaults			Units
				Initial data standard 200/400	Initial data CHN 200/400	Initial data EU 200/400	
d001	Output frequency monitoring	0.00 to 99.99/100.0 to 400.0 (Hz)	✓	-	-	-	-
d002	Output current monitoring	0.0 to 655.3 (A)	✗	-	-	-	-
d003	Rotation direction monitoring	F(forward rotation) / o(stopped) / r(reverse rotation)	✗	-	-	-	-
d004	PID feedback monitoring	0.00 to 99.99/100.0 to 999.9/1000. to 9999./1000 to 9999(10000 to 99990)/ ┌100 to ┌999(100000 to 999000)	✗	-	-	-	-
d005	Intelligent input terminal status	 (Example) terminal 1,2 : ON terminal 3 to 5 : OFF	✗	-	-	-	-
d006	Intelligent input terminal status	 (Example) terminal 11 : ON terminal relay : OFF	✗	-	-	-	-
d007	Scaled output frequency monitoring	0.00 to 99.99/100.0 to 999.9/1000. to 9999./1000 to 3999	✓	-	-	-	-
d013	Output voltage monitoring	0.0 to 600.0(V)	✗	-	-	-	-
d014	Input power monitoring	0.0 to 999.9(kW)	✗	-	-	-	-
d015	Cumulative power monitoring	0.0 to 999.9/1000. to 9999./1000 to 9999(10000 to 99990)/ ┌100 to ┌999(100000 to 999000)	✗	-	-	-	-
d016	Cumulative operation RUN time monitoring	0. to 9999./1000 to 9999(10000 to 99990)/ ┌100 to ┌999(100000 to 999000)(hr)	✗	-	-	-	-
d017	Cumulative power-on time monitoring	0. to 9999./1000 to 9999(10000 to 99990)/ ┌100 to ┌999(100000 to 999000)(hr)	✗	-	-	-	-
d018	Heat sink temperature monitoring	-020. to 120.0(°C)	✗	-	-	-	-

Chapter 13 Option

Func. Code	Name	"d" Function Description	Run Mode Edit	Defaults			Units
				Initial data standard 200/400	Initial data CHN 200/400	Initial data EU 200/400	
d050	Dual Monitoring	display the monitoring data selected by b160, b161	✗	-	-	-	-
d080	Trip counter	0. to 9999./1000 to 6553 (10000 to 65530)(time)	✗	-	-	-	-
d081	Trip monitoring 1	Factor, frequency(Hz),current(A), voltage across P-N(V), running time(hours), power-on time(hours)	✗	-	-	-	-
d082	Trip monitoring 2		✗	-	-	-	-
d083	Trip monitoring 3		✗	-	-	-	-
d084	Trip monitoring 4		✗	-	-	-	-
d085	Trip monitoring 5		✗	-	-	-	-
d086	Trip monitoring 6		✗	-	-	-	-
d090	Warning monitoring		Warning code	✗	-	-	-
d102	DC voltage monitoring	0.0 to 999.9/1000.(V)	✗	-	-	-	-
d104	Electronic thermal overload monitoring	0.0 to 100.0(%)	✗	-	-	-	-

13.1.3 Function mode (Display of NES1-OP,OPE-S/SR/SBK/SRmini)

Note) Mark "✓" in [Run Mode Edit] shows the accessible parameters when b031 is set "10", high level access.

Func. Code	Name	"F" Function Description	Run Mode Edit	Defaults			Units
				Initial data standard 200/400	Initial data CHN 200/400	Initial data EU 200/400	
F001	Output frequency setting	Standard default target frequency that determines constant motor speed, range is 0.00 / start frequency to maximum frequency (A004)	✓	0.00	←	←	Hz
F002	Acceleration time (1)	Standard default acceleration, range is 0.00 to 3600 seconds.	✓	10.00	←	←	s
F202	Acceleration time (1), 2 nd motor		✓	10.00	←	←	s
F003	Deceleration time (1)	Standard default deceleration, range is 0.00 to 3600 seconds.	✓	10.00	←	←	s
F203	Deceleration time (1), 2 nd motor		✓	10.00	←	←	s
F004	Keypad RUN key routing	Two options; select codes: 00 ...Forward 01 ...Reverse	✗	00	←	←	-

Chapter 13 Option

"A" Function			Run Mode Edit	Defaults			
Func. Code	Name	Description		Initial data standard 200/400	Initial data CHN 200/400	Initial data EU 200/400	Units
A001	Frequency source	Five options; select codes: 00 ...POT on ext. operator 01 ...Control terminal	✗	01	←	←	–
A201	Frequency source, 2 nd motor	02 ...Function F001 setting 03 ...Modbus network input 10 ...Calculate function output	✗	01	←	←	–
A002	Run command source	Three options; select codes: 01 ...Control terminal	✗	01	←	←	–
A202	Run command source, 2 nd motor	02 ...Run key on keypad, or digital operator 03 ...Modbus network input	✗	01	←	←	–
A003	Base frequency	Settable from 30.0 Hz to the maximum frequency(A004)	✗	60.0	50.0	50.0	Hz
A203	Base frequency, 2 nd motor	Settable from 30.0 Hz to the 2 nd maximum frequency(A204)	✗	60.0	50.0	50.0	Hz
A004	Maximum frequency	Settable from the base frequency to 400.0	✗	60.0	50.0	50.0	Hz
A204	Maximum frequency, 2 nd motor	Settable from the 2 nd base frequency to 400.0	✗	60.0	50.0	50.0	Hz
A011	[O/OI] input active range start frequency	The output frequency corresponding to the analog input range starting point, range is 0.00 to 400.00	✓	0.00	←	←	Hz
A012	[O/OI] input active range end frequency	The output frequency corresponding to the analog input range ending point, range is 0.0 to 400.00	✓	0.00	←	←	Hz
A013	[O/OI] input active range start voltage	The starting point (offset) for the active analog input range, range is 0. to 100.	✓	0.	←	←	%
A014	[O/OI] input active range end voltage	The ending point (offset) for the active analog input range, range is 0. to 100.	✓	100.	←	←	%
A015	[O/OI] input start frequency enable	Two options; select codes: 00...Use offset (A011 value) 01...Use 0Hz	✓	01	←	←	–
A016	Analog input filter	Range n = 1 to 31, 1 to 31 :•2ms filter	✓	31.	8	31	Spl.
A019	Multi-speed operation selection	Select codes: 00...Binary operation (8 speeds selectable with 3 terminals) 01...Bit operation (4 speeds selectable with 3 terminals)	✗	00	←	←	–
A020	Multi-speed freq. 0	Defines the first speed of a multi-speed profile, range is 0.00 / start frequency to 400.0 A020 = Speed 0 (1st motor)	✓	0.00	←	←	Hz

"A" Function			Run Mode Edit	Defaults			Units
Func. Code	Name	Description		Initial data standard 200/400	Initial data CHN 200/400	Initial data EU 200/400	
A220	Multi-speed freq. 0, 2 nd motor	Defines the first speed of a multi-speed profile or a 2nd motor, range is 0.00 / start frequency to 400.0 A220 = Speed 0 (2nd motor)	✓	0.00	←	←	Hz
A021 to A027	Multi-speed freq. 1 to 7 (for both motors)	Defines 7 more speeds, range is 0.00 / start frequency to 400.0. A021=Speed 1 ~ A027=Speed7	✓	See next row	←	←	Hz
		A021	✓	60.00	50.00	50.00	Hz
		A022	✓	40.00	35.00	35.00	Hz
		A023	✓	20.00	←	←	Hz
		A024 ~ A027	✓	0.00	←	←	Hz
A038	Jog frequency	Defines limited speed for jog, range is from start frequency to 9.99 Hz	✓	6.00	←	←	Hz
A039	Jog stop mode	Define how end of jog stops the motor; six options: 00...Free-run stop (invalid during run) 01...Controlled deceleration (invalid during run) 02...DC braking to stop(invalid during run) 03...Free-run stop (valid during run) 04...Controlled deceleration (valid during run) 05...DC braking to stop(valid during run)	✓	04	←	←	-
A041	Torque boost select	Two options: 00...Manual torque boost 01...Automatic torque boost	✗	00	←	←	-
A241	Torque boost select, 2 nd motor		✗	00	←	←	-
A042	Manual torque boost value	Can boost starting torque between 0 and 20% above normal V/f curve, range is 0.0 to 20.0%	✓	1.0	3.0	1.0	%
A242	Manual torque boost value, 2 nd motor		✓	1.0	3.0	1.0	%
A043	Manual torque boost frequency	Sets the frequency of the V/f breakpoint A in graph (top of previous page) for torque boost, range is 0.0 to 50.0%	✓	5.0	←	←	%
A243	Manual torque boost frequency, 2 nd motor		✓	5.0	←	←	%
A044	V/f characteristic curve	Three available V/f curves; 00...Constant torque 01...Reduced torque (1.7) 02...Free V/F	✗	00	←	←	-
A244	V/f characteristic curve, 2 nd motor		✗	00	←	←	-
A045	V/f gain	Sets voltage gain of the inverter, range is 20 to 100%	✓	100.	←	←	%
A245	V/f gain, 2 nd motor		✓	100.	←	←	%

Chapter 13 Option

"A" Function			Run Mode Edit	Defaults			
Func. Code	Name	Description		Initial data standard 200/400	Initial data CHN 200/400	Initial data EU 200/400	Units
A046	Voltage compensation gain for automatic torque boost	Sets voltage compensation gain under automatic torque boost, range is 0. to 255.	✓	100.	←	←	–
A246	Voltage compensation gain for automatic torque boost, 2 nd motor		✓	100.	←	←	–
A047	Slip compensation gain for automatic torque boost	Sets slip compensation gain under automatic torque boost, range is 0. to 255.	✓	100.	←	←	–
A247	Slip compensation gain for automatic torque boost, 2 nd motor		✓	100.	←	←	–
A051	DC braking enable	Three options; select codes: 00...Disable 01...Enable during stop 02...Frequency detection	✓	00	←	←	–
A052	DC braking frequency	The frequency at which DC braking begins, range is from the start frequency (b082) to 60.00Hz	✓	0.50	←	←	Hz
A053	DC braking wait time	The delay from the end of controlled deceleration to start of DC braking (motor free runs until DC braking begins), range is 0.0 to 5.0 seconds.	✓	0.0	←	←	s
A054	DC braking force for deceleration	Level of DC braking force, settable from 0 to 100%	✓	50.	←	←	%
A055	DC braking time for deceleration	Sets the duration for DC braking, range is from 0.0 to 10.0 seconds.	✓	0.5	←	←	s
A056	DC braking / edge or level detection for [DB] input	Two options; select codes: 00...Edge detection 01...Level detection	✓	01	←	←	–
A057	DC braking force at start	Level of DC braking force at start, settable from 0 to 100%	✓	0.	←	←	%
A058	DC braking time at start	Sets the duration for DC braking, range is from 0.0 to 10.0 seconds.	✓	0.0	←	←	s
A059	Carrier frequency during DC braking	Carrier frequency of DC braking performance, range is from 2.0 to 15.0kHz	✓	2.0	←	←	kHz

"A" Function			Run Mode Edit	Defaults			Units
Func. Code	Name	Description		Initial data standard 200/400	Initial data CHN 200/400	Initial data EU 200/400	
A061	Frequency upper limit	Sets a limit on output frequency less than the maximum frequency (A004). Range is from frequency lower limit (A062) to maximum frequency (A004). 0.00 setting is disabled >0.00 setting is enabled	✓	0.00	←	←	Hz
A261	Frequency upper limit, 2nd motor	Sets a limit on output frequency less than the maximum frequency (A204). Range is from frequency lower limit (A262) to maximum frequency (A204). 0.00 setting is disabled >0.00 setting is enabled	✓	0.00	←	←	Hz
A062	Frequency lower limit	Sets a limit on output frequency greater than zero. Range is start frequency (b082) to frequency upper limit (A061) 0.00 setting is disabled >0.00 setting is enabled	✓	0.00	←	←	Hz
A262	Frequency lower limit, 2nd motor	Sets a limit on output frequency greater than zero. Range is start frequency (b082) to frequency upper limit (A261) 0.00 setting is disabled >0.00 setting is enabled	✓	0.00	←	←	Hz
A063 A065 A067	Jump freq. (center) 1 to 3	Up to 3 output frequencies can be defined for the output to jump past to avoid motor resonances (center frequency) Range is 0.00 to 400.0 Hz	✓	0.00 0.00 0.00	←	←	Hz
A064 A066 A068	Jump freq. width (hysteresis) 1 to 3	Defines the distance from the center frequency at which the jump around occurs Range is 0.00 to 10.00 Hz	✓	0.50 0.50 0.50	←	←	Hz
A069	Acceleration hold frequency	Sets the frequency to hold acceleration, range is 0.00 to 400.00Hz	✓	0.00	←	←	Hz
A070	Acceleration hold time	Sets the duration of acceleration hold, range is 0.0 to 60.0 seconds.	✓	0.0	←	←	s
A071	PID enable	Enables PID function, three option codes: 00...PID Disable 01...PID Enable 02...PID Enable with reverse output	✓	00	←	←	-
A072	PID proportional gain	Proportional gain has a range of 0.00 to 25.00	✓	1.00	←	←	-
A073	PID integral time constant	Integral time constant has a range of 0.0 to 3600.0 seconds.	✓	1.0	←	←	s
A074	PID derivative time constant	Derivative time constant has a range of 0.00 to 100.00 seconds.	✓	0.00	←	←	s
A075	PV scale conversion	Process Variable (PV), scale factor (multiplier), range of 0.01 to 99.99	✓	1.00	←	←	-

Chapter 13 Option

Func. Code	Name	"A" Function Description	Run Mode Edit	Defaults			Units
				Initial data standard 200/400	Initial data CHN 200/400	Initial data EU 200/400	
A076	PV source	Selects source of Process Variable (PV), option codes: 01...[O/OI] terminal 02...Modbus network 10...Calculate function output	✓	01	←	←	–
A077	Reverse PID action	Two option codes: 00...PID input = SP-PV 01...PID input = -(SP-PV)	✓	00	←	←	–
A078	PID variation range	Sets the limit of PID output as percent of full scale, range is 0.0 to 100.0%	✓	0.0	←	←	%
A081	AVR function select	Automatic (output) voltage regulation, selects from three type of AVR functions, three option codes: 00...AVR enabled 01...AVR disabled 02...AVR enabled except during deceleration	✗	02	01	02	–
A281	AVR function select, 2 nd motor		✗	02	01	02	–
A082	AVR voltage select	200V class inverter settings:200/215/220/230/240 400V class inverter settings:380/400/415/440/460/480	✗	200/ 400	220/ 380	230/ 400	V
A282	AVR voltage select, 2 nd motor		✗	200/ 400	220/ 380	230/ 400	V
A083	AVR filter time constant	Define the time constant of the AVR filter, range is 0.000 to 1.000 seconds.	✓	0.030	←	←	s
A084	AVR deceleration gain	Gain adjustment of the braking performance, range is 50 to 200%	✓	100.	←	←	%
A085	Energy-saving operation mode	Two option codes: 00...Normal operation 01...Energy-saving operation	✗	00	←	←	–
A086	Energy-saving mode tuning	Range is 0.0 to 100.0 %.	✓	50.0	←	←	%
A092	Acceleration time (2)	Duration of 2 nd segment of acceleration, range is: 0.00 to 3600.00 seconds.	✓	10.00	←	←	s
A292	Acceleration time (2), 2 nd motor		✓	10.00	←	←	s
A093	Deceleration time (2)	Duration of 2 nd segment of deceleration, range is: 0.00 to 3600.00 seconds.	✓	10.00	←	←	s
A293	Deceleration time (2), 2 nd motor		✓	10.00	←	←	s
A094	Select method to switch to Acc2/Dec2 profile	Three options for switching from 1st to 2nd accel/decel: 00...2CH input from terminal 01...Transition frequency 02...Forward and reverse	✗	00	←	←	–
A294	Select method to switch to Acc2/Dec2 profile, 2 nd motor		✗	00	←	←	–

"A" Function			Run Mode Edit	Defaults			Units
Func. Code	Name	Description		Initial data standard 200/400	Initial data CHN 200/400	Initial data EU 200/400	
A095	Acc1 to Acc2 frequency transition point	Output frequency at which Accel1 switches to Accel2, range is 0.00 to 400.00 Hz	✗	0.00	←	←	Hz
A295	Acc1 to Acc2 frequency transition point, 2 nd motor		✗	0.00	←	←	Hz
A096	Dec1 to Dec2 frequency transition point	Output frequency at which Decel1 switches to Decel2, range is 0.0 to 400.0 Hz	✗	0.00	←	←	Hz
A296	Dec1 to Dec2 frequency transition point, 2 nd motor		✗	0.00	←	←	Hz
A097	Acceleration curve selection	Set the characteristic curve of Acc1 and Acc2, five options: 00...linear 01...S-curve 02...U-curve 03...Inverse U-curve	✗	00	←	←	-
A098	Deceleration curve selection	Set the characteristic curve of Dec1 and Dec2, options are same as above (A097)	✗	00	←	←	-
A131	Acceleration curve constant	Range is 1 to 10.	✓	2	←	←	-
A132	Deceleration curve constant	Range is 1 to 10.	✓	2	←	←	-
A141	A input select for calculate function	Seven options: 00...Operator 01...VR 02...Terminal [O/OI] input 04...RS485	✓	00	←	←	-
A142	B input select for calculate function	Seven options: 00...Operator 01...VR 02...Terminal [O/OI] input 04...RS485	✓	02	←	←	-
A143	Calculation symbol	Calculates a value based on the A input source (A141 selects) and B input source (A142 selects). Three options: 00...ADD (A input + B input) 01...SUB (A input - B input) 02...MUL (A input * B input)	✓	00	←	←	-
A145	ADD frequency	An offset value that is applied to the output frequency when the [ADD] terminal is ON. Range is 0.00 to 400.00 Hz	✓	0.00	←	←	Hz

Chapter 13 Option

Func. Code	Name	“A” Function Description	Run Mode Edit	Defaults			Units
				Initial data standard 200/400	Initial data CHN 200/400	Initial data EU 200/400	
A146	ADD direction select	Two options: 00...Plus (adds A145 value to the output frequency setting) 01...Minus (subtracts A145 value from the output frequency setting)	✓	00	←	←	-
A154	Deceleration hold frequency	Sets the frequency to hold deceleration, range is 0.00 to 400.00Hz	✓	0.00	←	←	Hz
A155	Deceleration hold time	Sets the duration of deceleration hold, range is 0.0 to 60.0 seconds.	✓	0.0	←	←	s
A156	PID sleep function action threshold	Sets the threshold for the action, set range 0.00 to 400.00 Hz	✓	0.00	←	←	Hz
A157	PID sleep function action delay time	Sets the delay time for the action, set range 0.0 to 25.5 seconds.	✓	0.0	←	←	s
A158	PID sleep function return threshold	A156 to 400.0(Hz)	✓	0.00	←	←	Hz
A161	[VR] input active range start frequency	The output frequency corresponding to the analog input range starting point, range is 0.00 to 400.00 Hz	✓	0.00	←	←	Hz
A162	[VR] input active range end frequency	The output frequency corresponding to the current input range ending point, range is 0.00 to 400.00 Hz	✓	0.00	←	←	Hz
A163	[VR] input active range start %	The starting point (offset) for the current input range, range is 0. to 100.%	✓	0.	←	←	%
A164	[VR] input active range end %	The ending point (offset) for the current input range, range is 0. to 100.%	✓	100.	←	←	%
A165	[VR] input start frequency select	Two options; select codes: 00...Use offset (A161 value) 01...Use 0Hz	✓	01	←	←	-

Func. Code	Name	"b" Function Description	Run Mode Edit	Defaults			Units
				Initial data standard 200/400	Initial data CHN 200/400	Initial data EU 200/400	
b001	Restart mode on power failure / under-voltage trip	Select inverter restart method, Four option codes: 00...Alarm output after trip, no automatic restart 01...Restart at 0Hz 02...Resume operation after frequency matching 03...Resume previous freq. after freq. matching, then decelerate to stop and display trip info	✓	00	←	←	–
b002	Allowable under-voltage power failure time	The amount of time a power input under-voltage can occur without tripping the power failure alarm. Range is 0.3 to 25 sec. If under-voltage exists longer than this time, the inverter trips, even if the restart mode is selected.	✓	1.0	←	←	s
b003	Retry wait time before motor restart	Time delay after under-voltage condition goes away, before the inverter runs motor again. Range is 0.3 to 100.0 seconds.	✓	1.0	←	←	s
b004	Instantaneous power failure / under-voltage trip alarm enable	Three option codes: 00...Disable 01...Enable 02...Disable during stop and decelerates to a stop	✓	00	←	←	–
b005	Number of restarts on power failure / under-voltage trip events	Two option codes: 00...Restart 16 times 01...Always restart	✓	00	←	←	–
b007	Restart frequency threshold	Restart the motor from 0Hz if the frequency becomes less than this set value during the motor is coasting, range is 0.00 to 400.00Hz	✓	0.50	←	←	Hz
b008	Restart mode on over voltage / over current trip	Select inverter restart method, Four option codes: 00...Alarm output after trip, no automatic restart 01...Restart at 0Hz 02...Resume operation after frequency matching 03...Resume previous freq. after active freq. matching, then decelerate to stop and display trip info	✓	00	←	←	–
b010	Number of retry on over voltage / over current trip	Range is 1 to 3 times	✓	3	←	←	–

Chapter 13 Option

Func. Code	Name	"b" Function Description	Run Mode Edit	Defaults			Units
				Initial data standard 200/400	Initial data CHN 200/400	Initial data EU 200/400	
b011	Retry wait time on over voltage / over current trip	Range is 0.3 to 100.0 sec.	✓	1.0	←	←	s
b012	Level of electronic thermal	Set a level between 20% and 100% for the rated inverter current.	✓	Rated current for each inverter model *1	←	←	A
b212	Level of electronic thermal, 2 nd motor		✓		←	←	A
b013	Electronic thermal characteristic	Select from three curves, option codes: 00...Reduced torque 01...Constant torque 02...Free setting	✓	01	←	←	-
b213	Electronic thermal characteristic, 2 nd motor		✓	01	←	←	-
b015	Free setting electronic thermal ~freq.1	Range is 0 to b017Hz	✓	0	←	←	Hz
b016	Free setting electronic thermal ~current1	Range is 0.00 to inverter rated current Amps	✓	0.00	←	←	A
b017	Free setting electronic thermal ~freq.2	Range is b015 to b019Hz	✓	0	←	←	Hz
b018	Free setting electronic thermal ~current2	Range is 0.00 to inverter rated current Amps	✓	0.00	←	←	A
b019	Free setting electronic thermal ~freq.3	Range is b017 to 400Hz	✓	0	←	←	Hz
b020	Free setting electronic thermal ~current3	Range is 0.00 to inverter rated current Amps	✓	0.00	←	←	A
b021	Overload restriction operation mode	Select the operation mode during overload conditions, three options, option codes: 00...Disabled 01...Enabled for acceleration and constant speed 02...Enabled for constant speed only	✓	01	←	←	-
b221	Overload restriction operation mode, 2 nd motor		✓	01	←	←	-

Func. Code	Name	Description	Run Mode Edit	Defaults			Units
				Initial data standard 200/400	Initial data CHN 200/400	Initial data EU 200/400	
b022	Overload restriction level	Sets the level of overload restriction, between 20% and 200% of the rated current of the inverter, setting resolution is 1% of rated current	✓	Rated current x 1.50	←	←	A
b222	Overload restriction level, 2 nd motor		✓	Rated current x 1.50	←	←	A
b023	Deceleration rate at overload restriction	Sets the deceleration rate when inverter detects overload, range is 0.1 to 3000.0, resolution 0.1 seconds.	✓	1.0	←	←	s
b223	Deceleration rate at overload restriction, 2 nd motor		✓	1.0	←	←	s
b024	Overload restriction operation mode 2	Select the operation mode during overload conditions, three options, option codes: 00...Disabled 01...Enabled for acceleration and constant speed 02...Enabled for constant speed only	✓	01	←	←	-
b025	Overload restriction level 2	Sets the level of overload restriction, between 20% and 200% of the rated current of the inverter, setting resolution is 1% of rated current	✓	Rated current x 1.50	←	←	A
b026	Deceleration rate 2 at overload restriction	Sets the deceleration rate when inverter detects overload, range is 0.1 to 3000.0, resolution 0.1 seconds.	✓	1.0	←	←	s
b027	OC suppression selection *	Two option codes: 00...Disabled 01...Enabled	✓	01	←	←	-
b028	Current level of active freq. matching	Sets the current level of active freq. matching restart, range is 0.2*inverter rated current to 2.0*inverter rated current, resolution 0.1 seconds.	✓	Rated current	←	←	A
b029	Deceleration rate of active freq. matching	Sets the deceleration rate when active freq. matching restart, range is 0.1 to 3000.0, resolution 0.1 seconds.	✓	0.5	←	←	s
b030	Start freq. of active freq. matching	Three option codes: 00...freq at previous shutoff 01...start from max. Hz 02...start from set frequency	✓	00	←	←	-

Chapter 13 Option

Func. Code	Name	"b" Function Description	Run Mode Edit	Defaults			Units
				Initial data standard 200/400	Initial data CHN 200/400	Initial data EU 200/400	
b031	Software lock mode selection	Prevents parameter changes, in five options, option codes: 00...all parameters except b031 are locked when [SFT] terminal is ON 01...all parameters except b031 and output frequency F001 are locked when [SFT] terminal is ON 02...all parameters except b031 are locked 03...all parameters except b031 and output frequency F001 are locked 10...High level access including b031 See appendix C for the accessible parameters in this mode.	✓	01	10	01	–
b034	Run/power ON warning time	Range is, 0.:Warning disabled 1. to 9999.: 10~99,990 hrs (unit: 10) 1000 to 6553: 100,000~655,350 hrs (unit: 100)	✓	0.	←	←	Hrs.
b035	Rotation direction restriction	Three option codes: 00...No restriction 01...Reverse rotation is restricted 02...Forward rotation is restricted	✗	00	←	←	–
b036	Reduced voltage start selection	Set range, 0 (disabling the function), 1 (approx. 4ms) to 250 (approx. 1s)	✓	3	←	←	–
b037	Function code display restriction	Five option codes: 00...Full display 01...Function-specific display 03...Data comparison display 04...Basic display 05...Monitor display only	✓	00	←	←	–
b038	Initial display selection	000...Func. code that SET key pressed last displayed.(*) 001~060...d001~d060 displayed 201...F001displayed 202...B display of LCD operator (In case of Digital operator, same 000 setting)	✓	001	←	←	–
b050	Controlled deceleration on power loss	Four option codes: 00...Disabled 01...Decelerates to a stop 02...Decelerates to a stop with DC bus voltage controlled 03...Decelerates to a stop with DC bus voltage controlled, then restart	✗	00	←	←	–
b051	DC bus voltage trigger level of ctrl. decel.	Setting of DC bus voltage to start controlled decel. operation. Range is 0.0 to 400.0(200V class inverter settings),0.0 to 800(400V class inverter settings)	✗	220.0/ 440.0	←	←	V
b052	Over-voltage threshold of ctrl. decel.	Setting the OV-LAD stop level of controlled decel. operation. Range is 0.0 to 400.0(200V class inverter settings),0.0 to 800(400V class inverter settings)	✗	360.0/ 720.0	←	←	V

Func. Code	Name	Description	Run Mode Edit	Defaults			Units
				Initial data standard 200/400	Initial data CHN 200/400	Initial data EU 200/400	
b053	Deceleration time of ctrl. decel.	Range is 0.10 to 300.00 seconds.	✗	1.00	←	←	s
b054	Initial freq. drop of ctrl. decel.	Setting of initial freq. drop. Range is 0.00 to 10.00 Hz	✗	0.00	←	←	Hz
b060	Maximum-limit level of window comparator (O/OI)	Set range, {Min.-limit level (b061) + hysteresis width (b062)x2} to 100 %	✓	100.	←	←	%
b061	Minimum-limit level of window comparator (O/OI)	Set range, 0 to {Max.-limit level (b060) - hysteresis width (b062)x2} maximum of 100 %	✓	0.	←	←	%
b062	Hysteresis width of window comparator (O/OI)	Set range, 0 to {Max.-limit level (b060) - Min.-limit level (b061)}/2 % (Maximum of 10%)	✓	0.	←	←	%
b070	Operation level at O/OI disconnection	Set range, 0 to 100%, or "no" (ignore)	✓	no	←	←	-
b078	Watt-hour clearance	Two option codes: 00...OFF 01...ON (press STR then clear)	✓	00	←	←	-
b079	Watt-hour display gain	Set range is, 1.to1000.	✓	1.	←	←	
b082	Start frequency	Sets the starting frequency for the inverter output, range is 0.01 to 9.99 Hz	✓	0.50	←	←	Hz
b083	Carrier frequency	Sets the PWM carrier (internal switching frequency), range is 2.0 to 15.0 kHz	✓	2.0	←	←	kHz
b084	Initialization mode (parameters or trip history)	Select initialized data, four option codes: 00...Initialization disabled 01...Clears Trip history 02...Initializes all Parameters 03...Clears Trip history and initializes all parameters	✗	00	←	←	-
b085	Country for initialization	Select default parameter values for country on initialization, two option codes: 00...Mode 1 01... Mode 2	✗	00	03	01	-
b086	Frequency scaling conversion factor	Specify a constant to scale the displayed frequency for d007 monitor, range is 0.01 to 99.99	✓	1.00	←	←	-
b087	STOP key enable	Select whether the STOP key on the keypad is enabled, three option codes: 00...ON(enabling) 01...OFF(disabling) 02... Only Reset(disabling only stop)	✓	00	←	←	-

Chapter 13 Option

Func. Code	Name	"b" Function Description	Run Mode Edit	Defaults			Units
				Initial data standard 200/400	Initial data CHN 200/400	Initial data EU 200/400	
b088	Restart mode after FRS	Selects how the inverter resumes operation when free-run stop (FRS) is cancelled, two options: 00...Restart from 0Hz 01...Restart from frequency detected from real speed of motor (freq. matching)	✓	00	←	←	-
b089	Automatic carrier frequency reduction	Three option codes: 00...Disabled 01...Enabled, depending on the output current 02...Enabled, depending on the heat-sink temperature	✗	00	←	←	-
b091	Stop mode selection	00(Dec and Stop) / 01(FRS)	✓	00	←	←	-
b094	Initialization on target data setting	00(ALL parameters)/ 01(expect terminal and communication data)	✗	00	←	←	-
b100	Free V/F setting, freq.1	Set range, 0 ~ value of b102	✗	0.	←	←	Hz
b101	Free V/F setting, voltage.1	Set range, 0.0 to 300.0V(200Vclass), 0.0 to 600V(400Vclass)	✗	0.0	←	←	V
b102	Free V/F setting, freq.2	Set range, value of b100 ~b104	✗	0.	←	←	Hz
b103	Free V/F setting, voltage.2	Set range, 0.0 to 300.0V(200Vclass), 0.0 to 600V(400Vclass)	✗	0.0	←	←	V
b104	Free V/F setting, freq.3	Set range, value of b102 ~b106	✗	0.	←	←	Hz
b105	Free V/F setting, voltage.3	Set range, 0.0 to 300.0V(200Vclass), 0.0 to 600V(400Vclass)	✗	0.0	←	←	V
b106	Free V/F setting, freq.4	Set range, value of b104 ~b108	✗	0.	←	←	Hz
b107	Free V/F setting, voltage.4	Set range, 0.0 to 300.0V(200Vclass), 0.0 to 600V(400Vclass)	✗	0.0	←	←	V
b108	Free V/F setting, freq.5	Set range, value of b108 ~b110	✗	0.	←	←	Hz
b109	Free V/F setting, voltage.5	Set range, 0.0 to 300.0V(200Vclass), 0.0 to 600V(400Vclass)	✗	0.0	←	←	V
b110	Free V/F setting, freq.6	Set range, value of b108 ~b112	✗	0.	←	←	Hz
b111	Free V/F setting, voltage.6	Set range, 0.0 to 300.0V(200Vclass), 0.0 to 600V(400Vclass)	✗	0.0	←	←	V

Func. Code	Name	"b" Function Description	Run Mode Edit	Defaults			Units
				Initial data standard 200/400	Initial data CHN 200/400	Initial data EU 200/400	
b112	Free V/F setting, freq.7	Set range, b110 ~ 400	✗	0.	←	←	Hz
b113	Free V/F setting, voltage.7	Setrange,0.0to300.0V(200Vclass), 0.0 to 600V(400Vclass)	✗	0.0	←	←	V
b130	Deceleration overvoltage suppression enable	00...Disabled 01...Enabled 02...Enabled with accel. 03...when CONST/DEC	✓	00	←	←	-
b131	Decel. overvolt. suppress level	DC bus voltage of suppression. Range is: 200V class...330 to 390 400V class...660 to 780	✓	360/ 720	←	←	V
b132	Decel. overvolt. suppress const.	Accel. rate when b130=02. Set range: 0.10 ~ 30.00 seconds.	✓	1.00	←	←	s
b133	Decel. overvolt. suppress proportional gain	Proportional gain when b130=01. Range is: 0.00 to 5.00	✓	0.20	←	←	-
b134	Decel. overvolt. suppress integral time	Integration time when b130=01. Range is: 0.0 to 150.0 seconds.	✓	1.0	←	←	s
b150	Display ex.operator connected	When an external operator is connected via RS-422 port, the built-in display is locked and shows only one "d" parameter configured in:001 ~ 050	✓	001	←	←	-
b160	1st parameter of Dual Monitor	Set any two "d" parameters in b160 and b161, then they can be monitored in d050. The two parameters are switched by up/down keys. Set range: 001 ~ 018	✓	001	←	←	-
b161	2nd parameter of Dual Monitor		✓	002	←	←	-
b163	Frequency set in monitoring	Two option codes: 00...Freq. set disabled 01...Freq. set enabled	✓	01	←	←	-
b164	Automatic return to the initial display	10 min. after the last key operation, display returns to the initial parameter set by b038. Two option codes: 00...Disable 01...Enable	✓	00	←	←	-
b165	Ex. operator com. loss action	Five option codes: 00...Trip 01...Trip after deceleration to a stop 02...Ignore 03...Coasting (FRS) 04...Decelerates to a stop	✓	02	←	←	-

Chapter 13 Option

"b" Function			Run Mode Edit	Defaults			Units
Func. Code	Name	Description		Initial data standard 200/400	Initial data CHN 200/400	Initial data EU 200/400	
b166	Data Read/Wri te select	00... Read/Write OK 01... Protected	✓	00	←	←	–
b180	Initializati on trigger (*)	This is to perform initialization by parameter input with b084, b085 and b094. Two option codes: 00...Initialization disable 01...Perform initialization	✗	00	←	←	–

"C" Function			Run Mode Edit	Defaults			Units
Func. Code	Name	Description		Initial data standard 200/400	Initial data CHN 200/400	Initial data EU 200/400	
C001	Input [1] function	Select input terminal [1] function, 34 options (see next section)	✓	00 [FW]	←	←	–
C002	Input [2] function	Select input terminal [2] function, 34 options (see next section)	✓	01 [RV]	←	←	–
C003	Input [3] function	Select input terminal [3] function, 34 options (see next section)	✓	02 [CF1]	←	←	–
C004	Input [4] function	Select input terminal [4] function, 34 options (see next section)	✓	03 [CF2]	←	←	–
C005	Input [5] function	Select input terminal [5] function, 34 options (see next section)	✓	18 [RS]	←	←	–
C011	Input [1] active state	Select logic conversion, two option codes: 00...normally open [NO] 01...normally closed [NC]	✓	00	←	←	–
C012	Input [2] active state		✓	00	←	←	–
C013	Input [3] active state		✓	00	←	←	–
C014	Input [4] active state		✓	00	←	←	–
C015	Input [5] active state		✓	00	←	←	–
C021	Output [11] function	27 programmable functions available for logic (discrete) outputs (see next section)	✓	01 [FA1]	←	←	–
C026	Alarm relay function	27 programmable functions available for logic (discrete) outputs (see next section)	✓	05 [AL]	←	←	–
C027	[FM] terminal selection (Pulse/PWM output)	9 programmable functions: 00...Output frequency (PWM) 01...Output current (PWM) 03...Output frequency (Pulse train) 04...Output voltage (PWM) 05...Input power (PWM) 06...Electronic thermal load ratio (PWM) 07...LAD frequency (PWM) 08...Output current (Pulse train) 10...Heat sink temperature (PWM)	✓	07	←	←	–
C030	Digital current monitor reference value	Current with digital current monitor output at 1,440Hz Range is 20%~200% of rated current	✓	Rated current	←	←	A
C031	Output [11] active state	Select logic conversion, two option codes: 00...normally open [NO] 01...normally closed [NC]	✓	00	←	←	–
C036	Alarm relay active state		✓	01	←	←	–
C038	Output mode of low current detection	Two option codes: 00...During acceleration, deceleration and constant speed 01...During constant speed only	✓	01	←	←	–
C039	Low current detection level	Set the level of low load detection, range is 0.00 to 2.00*inverter rated current	✓	Rated current	←	←	A
C040	Output mode of overload warning	Two option codes: 00...During accel., decel. and constant speed 01...During constant speed only	✓	01	←	←	–
C041	Overload warning level	Sets the overload warning signal level between 0% and 200% (from 0 to two time the rated current of the inverter)	✓	Rated current x 1.15	←	←	A

Chapter 13 Option

"C" Function			Run Mode Edit	Defaults			Units
Func. Code	Name	Description		Initial data standard 200/400	Initial data CHN 200/400	Initial data EU 200/400	
C241	Overload warning level, 2 nd motor		✓	Rated current x 1.15	←	←	A
C042	Frequency arrival setting for acceleration	Sets the frequency arrival setting threshold for the output frequency during acceleration, range is 0.00 to 400.00 Hz	✓	0.00	←	←	Hz
C043	Frequency arrival setting for deceleration	Sets the frequency arrival setting threshold for the output frequency during deceleration, range is 0.00 to 400.00 Hz	✓	0.00	←	←	Hz
C044	PID deviation level	Sets the allowable PID loop error magnitude (absolute value), SP-PV, range is 0.0 to 100%	✓	3.0	←	←	%
C052	PID FBV output high limit	When the PV exceeds this value, the PID loop turns OFF the PID second stage output, range is 0.0 to 100%	✓	100.0	←	←	%
C053	PID FBV output low limit	When the PV goes below this value, the PID loop turns ON the PID second stage output, range is 0.0 to 100%	✓	0.0	←	←	%
C061	Electronic thermal warning level	Set range is 0 to 100% Setting 0 means disabled.	✓	90	←	←	%
C063	Zero speed detection level	Set range is 0.00 to 100.00Hz	✓	0.00	←	←	Hz
C064	Heat sink overheat warning	Set range is 0 to 110 °C	✓	100.	←	←	°C
C070	Selection of OPE/Modbus	00 (OPE) / 01 (Modbus)	✗	00	←	←	-
C071	Communication speed	Five option codes: 04...4,800 bps 05...9,600 bps 06...19,200 bps 07...38,400 bps	✓	05	←	←	bps
C072	Modbus address	Set the address of the inverter on the network. Range is 1 to 247	✓	1.	←	←	-
C074	Communication parity	Three option codes: 00...No parity 01...Even parity 02...Odd parity	✓	00	←	←	-
C075	Communication stop bit	Two option codes: 01...1 bit 02...2 bit	✓	01	←	←	-
C076	Communication error select	Selects inverter response to communications error. Five options: 00...Trip 01...Decelerate to a stop and trip 02...Disable 03...Free run stop (coasting) 04...Decelerates to a stop	✓	02	←	←	-
C077	Communication error time-out	Sets the communications watchdog timer period. Range is 0.00 to 99.99 seconds. 0.0 = disabled	✓	0.00	←	←	s
C078	Communication wait time	Time the inverter waits after receiving a message before it transmits. Range is 0. to 1000. m seconds.	✓	0.	←	←	ms

"C" Function			Run Mode Edit	Defaults			Units
Func. Code	Name	Description		Initial data standard 200/400	Initial data CHN 200/400	Initial data EU 200/400	
C081	O/OI input span calibration	Scale factor between the external frequency command on terminals L–O /OI(voltage/current input) and the frequency output, range is 0.0 to 200%	✓	100.0	←	←	%
C091	Debug mode enable *	Displays debug parameters. Two option codes: 00...Disable 01...Enable <Do not set> (for factory use)	✓	00	←	←	–
C101	Up/Down memory mode selection	Controls speed setpoint for the inverter after power cycle. Two option codes: 00...Clear last frequency (return to default frequency F_{00})	✓	00	←	←	–
		01...Keep last frequency adjusted by UP/DWN					
C102	Reset selection	Determines response to Reset input [RS]. Three option codes: 00...Cancel trip state at input signal ON transition, stops inverter if in Run Mode 01...Cancel trip state at signal OFF transition, stops inverter if in Run Mode 02...Cancel trip state at input ON transition, no effect if in Run Mode	✓	00	←	←	–
C103	Restart mode after reset	Determines the restart mode after reset is given, two option codes: 00...Start with 0 Hz 01...Start with freq. matching	✓	00	←	←	–
C104	UP/DWN clear mode	Freq. set value when UDC signal is given to the input terminal, two option codes: 00...0 Hz 01...Original setting (in the memory at power on)	✓	00	←	←	–
C105	FM gain adjustment	Set range is 50 to 200%	✓	100.	←	←	%
C130	Output [11] on delay	Set range is 0.0 to 100.0 seconds.	✓	0.0	←	←	s
C131	Output [11] off delay		✓	0.0	←	←	s
C140	Relay output on delay	Set range is 0.0 to 100.0 seconds.	✓	0.0	←	←	s
C141	Relay output off delay		✓	0.0	←	←	s
C142	Logic output 1 operand A	All the programmable functions available for logic (discrete) outputs except LOG1 , no	✓	00	←	←	–
C143	Logic output 1 operand B		✓	00	←	←	–
C144	Logic output 1 operator	Applies a logic function to calculate [LOG] output state, Three options: 00...[LOG] = A AND B 01...[LOG] = A OR B 02...[LOG] = A XOR B	✓	00	←	←	–
C151	Button sensitivity selection	0 to 250 / no	✓	10	←	←	–

Chapter 13 Option

"C" Function			Run Mode Edit	Defaults			
Func. Code	Name	Description		Initial data standard 200/400	Initial data CHN 200/400	Initial data EU 200/400	Units
C152	Scroll sensitivity selection	1 to 20	✓	10	←	←	–
C155	Ground fault detection	00(OFF) / 01(ON)	✓	01	←	←	–
C157	Out phase loss detection	00(OFF) / 01(ON)	✓	00	←	←	–
C160	Input [1] response time	Sets response time of each input terminal, set range: 0(x 2 [ms]) to 200(x 2 [ms]) (0 to 400 [ms])	✓	1.	←	←	–
C161	Input [2] response time		✓	1.	←	←	–
C162	Input [3] response time		✓	1.	←	←	–
C163	Input [4] response time		✓	1.	←	←	–
C164	Input [5] response time		✓	1.	←	←	–
C169	Multistage speed determination time	Set range is 0. to 200. (x 10ms)	✓	0.	←	←	ms

"H" Function			Run Mode Edit	Defaults			
Func. Code	Name	Description		Initial data standard 200/400	Initial data CHN 200/400	Initial data EU 200/400	Units
H003	Motor capacity	Twelve selections: 0.10/0.20/0.40/0.55/0.75/1.10/1.50 /2.20/3.00/3.70/4.00/5.50	✗	Specified by the capacity of each inverter model	←	←	kW
H203	Motor capacity, 2 nd motor		✗		←	←	kW
H004	Motor poles setting	Five selections: 2 / 4 / 6 / 8	✗	4	←	←	poles
H204	Motor poles setting, 2 nd motor		✗	4	←	←	poles
H006	Motor stabilization constant	Motor constant (factory set), range is 0 to 255	✓	100.	←	←	–
H206	Motor stabilization constant, 2 nd motor		✓	100.	←	←	–

13.1.4 Monitoring mode (Display of WOP)

The initial state displays (d001) at the time of power activation by all means. When you fix it by any display, please change setting of (b038).

"d" Function				Defaults			
Func. Code (WOP)	Name	Description	Run Mode Edit	Initial data	Initial data	Initial data	Units
				standard	CHN	EU	
				200/400	200/400	200/400	
d001 (Output FQ)	Output frequency monitoring	0.00 to 400.00 (Hz)	✓	-	-	-	-
d002 (Output current)	Output current monitoring	0.0 to 655.3 (A)	✗	-	-	-	-
d003 (Rotation)	Rotation direction monitoring	FWD (forward rotation) STOP (stopped) REV(reverse rotation)	✗	-	-	-	-
d004 (PID-FB)	PID feedback monitoring	0.00 to 10000.0	✗	-	-	-	-
d005 (Input)	Intelligent input terminal status	1 to 5 terminal LLLLL/HHHHH	✗	-	-	-	-
d006 (Output)	Intelligent input terminal status	1, RY terminal LL/HH	✗	-	-	-	-
d007 (Scaled FQ)	Scaled output frequency monitoring	0.00 to 40000.00	✓	-	-	-	-
d013 (Output Voltage)	Output voltage monitoring	0.0 to 600.0(V)	✗	-	-	-	-
d014 (Input Power)	Input power monitoring	0.0 to 999.9(kW)	✗	-	-	-	-
d015 (kW-hour)	Cumulative power monitoring	0.0 to 999999.9	✗	-	-	-	-
d016 (RUN time)	Cumulative operation RUN time monitoring	0 to 999999(hr)	✗	-	-	-	-
d017 (ON time)	Cumulative power-on time monitoring	0 to 999999(hr)	✗	-	-	-	-
d018 (Heatsink Tmp.)	Heat sink temperature monitoring	-20 to 120.0(°C)	✗	-	-	-	-
d050 (Dual)	Dual Monitoring	display the monitoring data selected by b160, b161	✗	-	-	-	-
d080 (Trip Counter)	Trip counter	0. to 65535(time)	✗	-	-	-	-

Chapter 13 Option

"d" Function			Run Mode Edit	Defaults			
Func. Code (WOP)	Name	Description		Initial data	Initial data	Initial data	Units
				standard	CHN	EU	
			200/400	200/400	200/400		
d081 (ERR1)	Trip monitoring 1	Factor, frequency(Hz), current(A), voltage across P-N(V), running time(hours), power-on time(hours)	✗	-	-	-	-
d082 (ERR2)	Trip monitoring 2		✗	-	-	-	-
d083 (ERR3)	Trip monitoring 3		✗	-	-	-	-
d084 (ERR4)	Trip monitoring 4		✗	-	-	-	-
d085 (ERR5)	Trip monitoring 5		✗	-	-	-	-
d086 (ERR6)	Trip monitoring 6		✗	-	-	-	-
d090 (WARN)	Warning monitoring	Warning code	✗	-	-	-	-
d102 (DC Voltage)	DC voltage monitoring	0.0 to 1000.0(V)	✗	-	-	-	-
d104 (E.Thermal)	Electronic thermal overload monitoring	0.0 to 100.0(%)	✗	-	-	-	-

Note) Mark “✓” in [Run Mode Edit] shows the accessible parameters when b031 is set “10”, high level access.

“F” Function			Run Mode Edit	Defaults			Units
Func. Code (WOP)	Name	Description		Initial data	Initial data	Initial data	
				standard	CHN	EU	
			200/400	200/400	200/400		
F001 (Set Frequency)	Output frequency setting	Standard default target frequency that determines constant motor speed, range is 0.00 / start frequency to maximum frequency (A004)	✓	0.00	←	←	Hz
F002 (Accel.time1)	Acceleration time (1)	Standard default acceleration, range is 0.00 to 3600.00 seconds.	✓	10.00	←	←	s
F202 (Accel.time1-M2)	Acceleration time (1), 2 nd motor		✓	10.00	←	←	s
F003 (Decel.time1)	Deceleration time (1)	Standard default deceleration, range is 0.00 to 3600.00 seconds.	✓	10.00	←	←	s
F203 (Decel.time1-M2)	Deceleration time (1), 2 nd motor		✓	10.00	←	←	s
F004 (RUN key direction)	Keypad RUN key routing	Two options; select codes: 00...Forward 01 ...Reverse	✗	00	←	←	-

Chapter 13 Option

[Function mode (A Group)]

"A" Function			Run Mode Edit	Defaults			
Func. Code (WOP)	Name	Description		Initial data	Initial data	Initial data	Units
				standard	CHN	EU	
			200/400	200/400	200/400		
A001 (Frequency source)	Frequency source	Five options; select codes: 00 ...POT on ext. operator	✗	01	←	←	–
A201 (Frequency source-M2)	Frequency source, 2 nd motor	01 ...Control terminal 02 ...Function F001 setting 03 ...Modbus network input 10 ...Calculate function output	✗	01	←	←	–
A002 (RUN cmd source)	Run command source	Three options; select codes: 01 ...Control terminal	✗	01	←	←	–
A202 (RUN cmd source-M2)	Run command source, 2 nd motor	02 ...Run key on keypad, or digital operator 03 ...Modbus network input	✗	01	←	←	–
A003 (Base Frequency)	Base frequency	Settable from 30.0 Hz to the maximum frequency(A004)	✗	60.0	50.0	50.0	Hz
A203 (Base Frequency-M2)	Base frequency, 2 nd motor	Settable from 30.0 Hz to the 2 nd maximum frequency(A204)	✗	60.0	50.0	50.0	Hz
A004 (Max. Frequency)	Maximum frequency	Settable from the base frequency to 400.0	✗	60.0	50.0	50.0	Hz
A204 (Max. Frequency-M2)	Maximum frequency, 2 nd motor	Settable from the 2 nd base frequency to 400.0	✗	60.0	50.0	50.0	Hz
A011 ([O/OI] start FQ)	[O/OI] input active range start frequency	The output frequency corresponding to the analog input range starting point, range is 0.00 to 400.00	✓	0.00	←	←	Hz

"A" Function			Run Mode Edit	Defaults			
Func. Code (WOP)	Name	Description		Initial data	Initial data	Initial data	Units
				standard	CHN	EU	
			200/400	200/400	200/400		
A012 ([O/OI] end FQ)	[O/OI] input active range end frequency	The output frequency corresponding to the analog input range ending point, range is 0.0 to 400.00	✓	0.00	←	←	Hz
A013 ([O/OI] start %)	[O/OI] input active range start voltage	The starting point (offset) for the active analog input range, range is 0. to 100.	✓	0.	←	←	%
A014 ([O/OI] end %)	[O/OI] input active range end voltage	The ending point (offset) for the active analog input range, range is 0. to 100.	✓	100.	←	←	%
A015 ([O/OI] start FQ select)	[O/OI] input start frequency enable	Two options; select codes: 00...Use offset (A011 value) 01...Use 0Hz	✓	01	←	←	-
A016 (Analog-in filter)	Analog input filter	Range n = 1 to 31, 1 to 31 :2ms filter	✓	31.	8	31	Spl.
A019 (Multispeed select)	Multi-speed operation selection	Select codes: 00...Binary operation (8 speeds selectable with 3 terminals) 01...Bit operation (4 speeds selectable with 3 terminals)	✗	00	←	←	-
A020 (Multispeed 0)	Multi-speed freq. 0	Defines the first speed of a multi-speed profile, range is 0.00 / start frequency to 400.0 A020 = Speed 0 (1st motor)	✓	0.00	←	←	Hz
A220 (Multispeed 0-M2)	Multi-speed freq. 0, 2 nd motor	Defines the first speed of a multi-speed profile or a 2nd motor, range is 0.00 / start frequency to 400.0 A220 = Speed 0 (2nd motor)	✓	0.00	←	←	Hz
A021 to A027 (Multispeed 1 to Multispeed 7)	Multi-speed freq. 1 to 7 (for both motors)	Defines 7 more speeds, range is 0.00 / start frequency to 400.0. A021=Speed 1 ~A027=Speed7	✓	See next row	←	←	Hz
		A021	✓	60.00	50.00	50.00	Hz
		A022	✓	40.00	35.00	35.00	Hz
		A023	✓	20.00	←	←	Hz
		A024~A027	✓	0.00	←	←	Hz

Chapter 13 Option

"A" Function			Run Mode Edit	Defaults			
Func. Code (WOP)	Name	Description		Initial data	Initial data	Initial data	Units
				standard 200/400	CHN 200/400	EU 200/400	
A038 (Jog frequency)	Jog frequency	Defines limited speed for jog, range is from start frequency to 9.99 Hz	✓	6.00	←	←	Hz
A039 (Jog stop mode)	Jog stop mode	Define how end of jog stops the motor; six options: 00...Free-run stop (invalid during run) 01...Controlled deceleration (invalid during run) 02...DC braking to stop(invalid during run) 03...Free-run stop (valid during run) 04...Controlled deceleration (valid during run) 05...DC braking to stop(valid during run)	✓	04	←	←	–
A041 (TRQ boost sel)	Torque boost select	Two options: 00...Manual torque boost	✗	00	←	←	–
A241 (TRQ boost sel-M2)	Torque boost select, 2 nd motor	01...Automatic torque boost	✗	00	←	←	–
A042 (TRQ boost V%)	Manual torque boost value	Can boost starting torque between 0 and 20% above normal V/f curve, range is 0.0 to 20.0%	✓	1.0	3.0	1.0	%
A242 (TRQ boost V%-M2)	Manual torque boost value, 2 nd motor		✓	1.0	3.0	1.0	%
A043 (TRQ boost FQ%)	Manual torque boost frequency	Sets the frequency of the V/f breakpoint A in graph (top of previous page) for torque boost, range is 0.0 to 50.0%	✓	5.0	←	←	%
A243 (TRQ boost FQ%-M2)	Manual torque boost frequency, 2 nd motor		✓	5.0	←	←	%
A044 (V/F select)	V/f characteristic curve	Three available V/f curves; 00...Constant torque	✗	00	←	←	–
A244 (V/F select-M2)	V/f characteristic curve, 2 nd motor	01...Reduced torque (1.7) 02...Free V/F	✗	00	←	←	–

"A" Function			Run Mode Edit	Defaults			Units
Func. Code (WOP)	Name	Description		Initial data	Initial data	Initial data	
				standard 200/400	CHN 200/400	EU 200/400	
A045 (V/F gain)	V/f gain	Sets voltage gain of the inverter, range is 20 to 100%	✓	100.	←	←	%
A245 (V/F gain-M2)	V/f gain, 2 nd motor		✓	100.	←	←	%
A046 (A.TQ-BST V gain)	Voltage compensation gain for automatic torque boost	Sets voltage compensation gain under automatic torque boost, range is 0 to 255	✓	100.	←	←	–
A246 (A.TQ-BST V gain-M2)	Voltage compensation gain for automatic torque boost, 2 nd motor		✓	100.	←	←	–
A047 (A.TQ-BST SL gain)	Slip compensation gain for automatic torque boost	Sets slip compensation gain under automatic torque boost, range is 0 to 255	✓	100.	←	←	–
A247 (A.TQ-BST SL gain-M2)	Slip compensation gain for automatic torque boost, 2 nd motor		✓	100.	←	←	–
A051 (DB enable)	DC braking enable	Three options; select codes: 00...Disable 01...Enable during stop 02...Frequency detection	✓	00	←	←	–
A052 (DB Frequency)	DC braking frequency	The frequency at which DC braking begins, range is 0.00to 60.00Hz	✓	0.50	←	←	Hz
A053 (DB wait time)	DC braking wait time	The delay from the end of controlled deceleration to start of DC braking (motor free runs until DC braking begins), range is 0.0 to 5.0 seconds.	✓	0.0	←	←	s
A054 (DB force)	DC braking force for deceleration	Level of DC braking force, settable from 0 to 100%	✓	50.	←	←	%
A055 (DB decel time)	DC braking time for deceleration	Sets the duration for DC braking, range is from 0.0 to 10.0 seconds.	✓	0.5	←	←	s
A056 (DB input select)	DC braking / edge or level detection for [DB] input	Two options; select codes: 00...Edge detection 01...Level detection	✓	01	←	←	–
A057 (DB force start)	DC braking force at start	Level of DC braking force at start, settable from 0 to 100%	✓	0.	←	←	%

Chapter 13 Option

"A" Function			Run Mode Edit	Defaults			
Func. Code (WOP)	Name	Description		Initial data	Initial data	Initial data	Units
				standard	CHN	EU	
			200/400	200/400	200/400		
A058 (DB time start)	DC braking time at start	Sets the duration for DC braking, range is from 0.0 to 10.0 seconds.	✓	0.0	←	←	s
A059 (DB carrier FQ)	Carrier frequency during DC braking	Carrier frequency of DC braking performance, range is from 2.0 to 15.0kHz	✓	2.0	←	←	kHz
A061 (FQ upper limit)	Frequency upper limit	Sets a limit on output frequency less than the maximum frequency (A004). Range is from frequency lower limit (A062) to maximum frequency (A004). 0.00 setting is disabled >0.00 setting is enabled	✓	0.00	←	←	Hz
A261 (FQ upper limit-M2)	Frequency upper limit, 2nd motor	Sets a limit on output frequency less than the maximum frequency (A204). Range is from frequency lower limit (A262) to maximum frequency (A204). 0.00 setting is disabled >0.00 setting is enabled	✓	0.00	←	←	Hz
A062 (FQ lower limit-M2)	Frequency lower limit	Sets a limit on output frequency greater than zero. Range is start frequency (b082) to frequency upper limit (A061) 0.00 setting is disabled >0.00 setting is enabled	✓	0.00	←	←	Hz
A262 (FQ lower limit-M2)	Frequency lower limit, 2nd motor	Sets a limit on output frequency greater than zero. Range is start frequency (b082) to frequency upper limit (A261) 0.00 setting is disabled >0.00 setting is enabled	✓	0.00	←	←	Hz

"A" Function			Run Mode Edit	Defaults			
Func. Code (WOP)	Name	Description		Initial data	Initial data	Initial data	Units
				standard	CHN	EU	
			200/400	200/400	200/400		
A063 (Jump FQ1 Center) A065 (Jump FQ2 Center) A067 (Jump FQ3 Center)	Jump freq. (center) 1 to 3	Up to 3 output frequencies can be defined for the output to jump past to avoid motor resonances (center frequency) Range is 0.00 to 400.00 Hz	✓	0.00 0.00 0.00	←	←	Hz
A064 (Jump FQ1 Width) A066 (Jump FQ2 Width) A068 (Jump FQ3 Width)	Jump freq. width (hysteresis) 1 to 3	Defines the distance from the center frequency at which the jump around occurs Range is 0.00 to 10.00 Hz	✓	0.50 0.50 0.50	←	←	Hz
A069 (Accel hold FQ)	Acceleration hold frequency	Sets the frequency to hold acceleration, range is 0.00 to 400.00Hz	✓	0.00	←	←	Hz
A070 (Accel hold time)	Acceleration hold time	Sets the duration of acceleration hold, range is 0.0 to 60.0 seconds.	✓	0.0	←	←	s
A071 (PID enable)	PID enable	Enables PID function, three option codes: 00...PID Disable 01...PID Enable 02...PID Enable with reverse output	✓	00	←	←	-
A072 (PID P gain)	PID proportional gain	Proportional gain has a range of 0.00 to 25.00	✓	1.00	←	←	-
A073 (PID I gain)	PID integral time constant	Integral time constant has a range of 0.0 to 3600.0 seconds.	✓	1.0	←	←	s
A074 (PID D gain)	PID derivative time constant	Derivative time constant has a range of 0.00 to 100.00 seconds.	✓	0.00	←	←	s
A075 (PV scale convert)	PV scale conversion	Process Variable (PV), scale factor (multiplier), range of 0.01 to 99.99	✓	1.00	←	←	-

Chapter 13 Option

"A" Function			Run Mode Edit	Defaults			
Func. Code (WOP)	Name	Description		Initial data	Initial data	Initial data	Units
				standard	CHN	EU	
			200/400	200/400	200/400		
A076 (PV source select)	PV source	Selects source of Process Variable (PV), option codes: 01...[O/OI] terminal 02...Modbus network 10...Calculate function output	✓	01	←	←	–
A077 (Reverse PID action)	Reverse PID action	Two option codes: 00...PID input = SP-PV 01...PID input = -(SP-PV)	✓	00	←	←	–
A078 (PID limit)	PID variation range	Sets the limit of PID output as percent of full scale, range is 0.0 to 100.0%	✓	0.0	←	←	%
A081 (AVR select)	AVR function select	Automatic (output) voltage regulation, selects from three type of AVR functions, three option codes:	✗	02	01	02	–
A281 (AVR select-M2)	AVR function select, 2 nd motor	00...AVR enabled 01...AVR disabled 02...AVR enabled except during deceleration	✗	02	01	02	–
A082 (AVR voltage sel)	AVR voltage select	200V class inverter settings:200/215/220/230/240	✗	200/400	220/380	230/400	V
A282 (AVR voltage sel-M2)	AVR voltage select, 2 nd motor	400V class inverter settings: ...380/400/415/440/460/480	✗	200/400	220/380	230/400	V
A083 (AVR filter time)	AVR filter time constant	Define the time constant of the AVR filter, range is 0.000 to 1.000 seconds.	✓	0.030	←	←	s
A084 (OED voltage gain)	AVR deceleration gain	Gain adjustment of the braking performance, range is 50 to 200%	✓	100.	←	←	%
A085 (Energy-saving mode)	Energy-saving operation mode	Two option codes: 00...Normal operation 01...Energy-saving operation	✗	00	←	←	–
A086 (Energy-saving tune)	Energy-saving mode tuning	Range is 0.0 to 100.0 %.	✓	50.0	←	←	%
A092 (Accel.time2)	Acceleration time (2)	Duration of 2 nd segment of	✓	10.00	←	←	s

"A" Function			Run Mode Edit	Defaults			Units
Func. Code (WOP)	Name	Description		Initial data	Initial data	Initial data	
				standard	CHN	EU	
			200/400	200/400	200/400		
A292 (Accel.time2-M2)	Acceleration time (2), 2 nd motor	acceleration, range is: 0.00 to 3600.00 seconds.	✓	10.00	←	←	s
A093 (Decel.time2)	Deceleration time (2)	Duration of 2 nd segment of deceleration, range is: 0.00 to 3600.00 seconds.	✓	10.00	←	←	s
A293 (Decel.time2-M2)	Deceleration time (2), 2 nd motor	Duration of 2 nd segment of deceleration, range is: 0.00 to 3600.00 seconds.	✓	10.00	←	←	s
A094 (Acc2/Dec2 sel)	Select method to switch to Acc2/Dec2 profile	Three options for switching from 1st to 2nd accel/decel: 00...2CH input from terminal	✗	00	←	←	-
A294 (Acc2/Dec2 sel-M2)	Select method to switch to Acc2/Dec2 profile, 2 nd motor	01...Transition frequency 02...Forward and reverse	✗	00	←	←	-
A095 (Acc1-2 FQ)	Acc1 to Acc2 frequency transition point	Output frequency at which Accel1 switches to Accel2, range is 0.00 to 400.00 Hz	✗	0.00	←	←	Hz
A295 (Acc1-2 FQ-M2)	Acc1 to Acc2 frequency transition point, 2 nd motor	Output frequency at which Accel1 switches to Accel2, range is 0.00 to 400.00 Hz	✗	0.00	←	←	Hz
A096 (Dec1-2 FQ)	Dec1 to Dec2 frequency transition point	Output frequency at which Decel1 switches to Decel2, range is 0.00 to 400.00 Hz	✗	0.00	←	←	Hz
A296 (Dec1-2 FQ-M2)	Dec1 to Dec2 frequency transition point, 2 nd motor	Output frequency at which Decel1 switches to Decel2, range is 0.00 to 400.00 Hz	✗	0.00	←	←	Hz
A097 (Accel.curve select)	Acceleration curve selection	Set the characteristic curve of Acc1 and Acc2, five options: 00...linear 01...S-curve 02...U-curve 03...Inverse U-curve	✗	00	←	←	-
A098 (Decel.curve select)	Deceleration curve selection	Set the characteristic curve of Dec1 and Dec2, options are same as above (A097)	✗	00	←	←	-
A131 (Accel.curve const)	Acceleration curve constant	Range is 1 to 10	✓	2	←	←	-
A132 (Decel.curve const)	Deceleration curve constant	Range is 1 to 10	✓	2	←	←	-

Chapter 13 Option

"A" Function			Run Mode Edit	Defaults			
Func. Code (WOP)	Name	Description		Initial data	Initial data	Initial data	Units
				standard	CHN	EU	
			200/400	200/400	200/400		
A141 (A-input calc.FQ)	A input select for calculate function	Seven options: 00...Operator 01...VR 02...Terminal [O/OI] input 04...RS485	✓	00	←	←	-
A142 (B-input calc.FQ)	B input select for calculate function	Seven options: 00...Operator 01...VR 02...Terminal [O/OI] input 04...RS485	✓	02	←	←	-
A143 (Calculation symbol)	Calculation symbol	Calculates a value based on the A input source (A141 selects) and B input source (A142selects). Three options: 00...ADD (A input + B input) 01...SUB (A input - B input) 02...MUL (A input * B input)	✓	00	←	←	-
A145 (Add frequency)	ADD frequency	An offset value that is applied to the output frequency when the [ADD] terminal is ON. Range is 0.00 to 400.00 Hz	✓	0.00	←	←	Hz
A146 (Add direction)	ADD direction select	Two options: 00...Plus (adds A145 value to the output frequency setting) 01...Minus (subtracts A145 value from the output frequency setting)	✓	00	←	←	-
A154 (Decel hold FQ)	Deceleration hold frequency	Sets the frequency to hold deceleration, range is 0.00 to 400.00Hz	✓	0.00	←	←	Hz
A155 (Decel hold time)	Deceleration hold time	Sets the duration of deceleration hold, range is 0.0 to 60.0 seconds.	✓	0.0	←	←	s
A156 (PID sleep level)	PID sleep function action threshold	Sets the threshold for the action, set range 0.00 to 400.00 Hz	✓	0.00	←	←	Hz

"A" Function			Run Mode Edit	Defaults			
Func. Code (WOP)	Name	Description		Initial data	Initial data	Initial data	Units
				standard 200/400	CHN 200/400	EU 200/400	
A157 (PID sleep delay)	PID sleep function action delay time	Sets the delay time for the action, set range 0.0 to 25.5 seconds.	✓	0.0	←	←	s
A158 (PID sleep Release)	PID sleep function return threshold	A156 to 400.0(Hz)	✓	0.00	←	←	Hz
A161 (VR start FQ)	[VR] input active range start frequency	The output frequency corresponding to the analog input range starting point, range is 0.00 to 400.00 Hz	✓	0.00	←	←	Hz
A162 (VR end FQ)	[VR] input active range end frequency	The output frequency corresponding to the current input range ending point, range is 0.00 to 400.00 Hz	✓	0.00	←	←	Hz
A163 (VR start %)	[VR] input active range start %	The starting point (offset) for the current input range, range is 0 to 100%	✓	0.	←	←	%
A164 (VR end %)	[VR] input active range end %	The ending point (offset) for the current input range, range is 0 to 100%	✓	100.	←	←	%
A165 (VR start FQ select)	[VR] input start frequency select	Two options; select codes: 00...Use offset (A161 value) 01...Use 0Hz	✓	01	←	←	-

Chapter 13 Option

"b" Function			Run Mode Edit	Defaults			
Func. Code (WOP)	Name	Description		Initial data	Initial data	Initial data	Units
				standard 200/400	CHN 200/400	EU 200/400	
b001 (Restart mode UV)	Restart mode on power failure / under-voltage trip	Select inverter restart method, Four option codes: 00...Alarm output after trip, no automatic restart 01...Restart at 0Hz 02...Resume operation after frequency matching 03...Resume previous freq. after freq. matching, then decelerate to stop and display trip info	✓	00	←	←	—
b002 (Allowable UV time)	Allowable under-voltage power failure time	The amount of time a power input under-voltage can occur without tripping the power failure alarm. Range is 0.3 to 25.0 sec. If under-voltage exists longer than this time, the inverter trips, even if the restart mode is selected.	✓	1.0	←	←	s
b003 (Retry wait time UV)	Retry wait time before motor restart	Time delay after under-voltage condition goes away, before the inverter runs motor again. Range is 0.3 to 100.0 seconds.	✓	1.0	←	←	s
b004 (UV trip on stop)	Instantaneous power failure / under-voltage trip alarm enable	Three option codes: 00...Disable 01...Enable 02...Disable during stop and decelerates to a stop	✓	00	←	←	—
b005 (No. of restart UV)	Number of restarts on power failure / under-voltage trip events	Two option codes: 00...Restart 16 times 01...Always restart	✓	00	←	←	—
b007 (Restart min.FQ)	Restart frequency threshold	Restart the motor from 0Hz if the frequency becomes less than this set value during the motor is coasting, range is 0.00 to 400.00Hz	✓	0.50	←	←	Hz

"b" Function			Run Mode Edit	Defaults			Unit s
Func. Code (WOP)	Name	Description		Initial data	Initial data	Initial data	
				standard 200/400	CHN 200/400	EU 200/400	
b008 (Restart mode OV/OC)	Restart mode on over voltage / over current trip	Select inverter restart method, Four option codes: 00...Alarm output after trip, no automatic restart 01...Restart at 0Hz 02...Resume operation after frequency matching 03...Resume previous freq. after active freq. matching, then decelerate to stop and display trip info	✓	00	←	←	–
b010 (No. of restart OV/OC)	Number of retry on over voltage / over current trip	Range is 1 to 3 times	✓	3	←	←	–
b011 (Retry wait time OV/OC)	Retry wait time on over voltage / over current trip	Range is 0.3 to 100.0 sec.	✓	1.0	←	←	s
b012 (E.Thermal Level)	Level of electronic thermal	Set a level between 20% and 100% for the rated inverter current.	✓	Rated current for each inverter model *1	←	←	A
b212 (E.Thermal Level-M2)	Level of electronic thermal, 2 nd motor		✓		←	←	A
b013 (E.Thermal Character)	Electronic thermal characteristic	Select from three curves, option codes: 00...Reduced torque 01...Constant torque 02...Free setting	✓	01	←	←	–
b213 (E.Thermal Charact-M2)	Electronic thermal characteristic, 2 nd motor		✓	01	←	←	–
b015 (Free E.Thermal FQ-1)	Free setting electronic thermal ~freq.1	Range is 0 to b017 Hz	✓	0	←	←	Hz
b016 (Free E.Thermal I-1)	Free setting electronic thermal ~current1	Range is 0.00 to inverter rated current Amps	✓	0.00	←	←	A
b017 (Free E.Thermal FQ-2)	Free setting electronic thermal ~freq.2	Range is b015 to b019 Hz	✓	0	←	←	Hz
b018 (Free E.Thermal I-2)	Free setting electronic thermal ~current2	Range is 0.00 to inverter rated current Amps	✓	0.00	←	←	A

Chapter 13 Option

"b" Function			Run Mode Edit	Defaults			
Func. Code (WOP)	Name	Description		Initial data	Initial data	Initial data	Units
				standard 200/400	CHN 200/400	EU 200/400	
b019 (Free E.Thermal FQ-3)	Free setting electronic thermal ~freq.3	Range is b017 to 400Hz	✓	0	←	←	Hz
b020 (Free E.Thermal I-3)	Free setting electronic thermal ~current3	Range is 0.00 to inverter rated current Amps	✓	0.00	←	←	A
b021 (OL restrict mode)	Overload restriction operation mode	Select the operation mode during overload conditions, three options, option codes: 00...Disabled 01...Enabled for acceleration and constant speed 02...Enabled for constant speed only	✓	01	←	←	-
b221 (OL restrict mode-M2)	Overload restriction operation mode, 2 nd motor		✓	01	←	←	-
b022 (OL restrict level)	Overload restriction level	Sets the level of overload restriction, between 20% and 200% of the rated current of the inverter, setting resolution is 1% of rated current	✓	Rated current x 1.50	←	←	A
b222 (OL restrict level-M2)	Overload restriction level, 2 nd motor		✓	Rated current x 1.50	←	←	A
b023 (Decel.rate OL restrict)	Deceleration rate at overload restriction	Sets the deceleration rate when inverter detects overload, range is 0.1 to 3000.0, resolution 0.1 seconds.	✓	1.0	←	←	s
b223 (Decel.rate OL rstr-M2)	Deceleration rate at overload restriction, 2 nd motor		✓	1.0	←	←	s
b024 (OL restrict 2 mode)	Overload restriction operation mode 2	Select the operation mode during overload conditions, three options, option codes: 00...Disabled 01...Enabled for acceleration and constant speed 02...Enabled for constant speed only	✓	01	←	←	-
b025 (OL restrict 2 level)	Overload restriction level 2	Sets the level of overload restriction, between 20% and 200% of the rated current of the inverter, setting resolution is 1% of rated current	✓	Rated current x 1.50	←	←	A
b026 (Decel.rate OL 2 rstr)	Deceleration rate 2 at overload restriction	Sets the deceleration rate when inverter detects overload, range is 0.1 to 3000.0, resolution 0.1 seconds.	✓	1.0	←	←	s

"b" Function			Run Mode Edit	Defaults			Units
Func. Code (WOP)	Name	Description		Initial data	Initial data	Initial data	
				standard 200/400	CHN 200/400	EU 200/400	
b027 (OC suppress select)	OC suppression selection *	Two option codes: 00...Disabled 01...Enabled	✓	01	←	←	–
b028 (Curnt Active F-match)	Current level of active freq. matching	Sets the current level of active freq. matching restart, range is 0.2*inverter rated current to 2.0*inverter rated current, resolution 0.1 seconds.	✓	Rated current	←	←	A
b029 (Decel.rate act.F-match)	Deceleration rate of active freq. matching	Sets the deceleration rate when active freq. matching restart, range is 0.1 to 3000.0, resolution 0.1 seconds.	✓	0.5	←	←	s
b030 (Start FQ act.F-match)	Start freq. of active freq. matching	Three option codes: 00...freq at previous shutoff 01...start from max. Hz 02...start from set frequency	✓	00	←	←	–
b031 (Softlock select)	Software lock mode selection	Prevents parameter changes, in five options, option codes: 00...all parameters except b031 are locked when [SFT] terminal is ON 01...all parameters except b031 and output frequency F001 are locked when [SFT] terminal is ON 02...all parameters except b031 are locked 03...all parameters except b031 and output frequency F001are locked 10...High level access including b031 See appendix C for the accessible parameters in this mode.	✓	01	10	01	–
b034 (RNT/ONT time)	Run/power ON warning time	Range is, 0:Warning disabled 1 to 65535 hrs	✓	0.	←	←	Hrs.
b035 (Rotation restrction)	Rotation direction restriction	Three option codes: 00...No restriction 01...Reverse rotation is restricted 02...Forward rotation is restricted	✗	00	←	←	–

Chapter 13 Option

"b" Function			Run Mode Edit	Defaults			
Func. Code (WOP)	Name	Description		Initial data	Initial data	Initial data	Units
				standard	CHN	EU	
			200/400	200/400	200/400		
b036 (Reduced V start)	Reduced voltage start selection	Set range, 0 (disabling the function), 1 (approx. 4ms) to 250 (approx. 1s)	✓	3	←	←	–
b037 (Display restriction)	Function code display restriction	Five option codes: 00...Full display 01...Function-specific display 03...Data comparison display 04...Basic display 05...Monitor display only	✓	00	←	←	–
b038 (Initial display)	Initial display selection	000...Func. code that SET key pressed last displayed.(*) 001~060...d001~d060 displayed 201...F001displayed 202...B display of LCD operator (In case of Digital operator, same 000□setting)	✓	001	←	←	–
b050 (Ctrl d decel.select)	Controlled deceleration on power loss	Four option codes: 00...Disabled 01...Decelerates to a stop 02...Decelerates to a stop with DC bus voltage controlled 03...Decelerates to a stop with DC bus voltage controlled, then restart	✗	00	←	←	–
b051 (DC Volt ctrl d.decel)	DC bus voltage trigger level of ctrl. decel.	Setting of DC bus voltage to start controlled decel. operation. Range is 0.0 to 400.0/800.0	✗	220.0/ 440.0	←	←	V
b052 (OV lvl ctrl d.decel)	Over-voltage threshold of ctrl. decel.	Setting the OV-LAD stop level of controlled decel. operation. Range is 0.0 to 400.0/800.0	✗	360.0/ 720.0	←	←	V
b053 (Decel time ctrl d.dec)	Deceleration time of ctrl. decel.	Range is 0.01 to 300.00 seconds.	✗	1.00	←	←	s
b054 (FQ drop ctrl d.decel)	Initial freq. drop of ctrl. decel.	Setting of initial freq. drop. Range is 0.00 to 10.00 Hz	✗	0.00	←	←	Hz
b060 (Windw comp [O/OI] max)	Maximum-limit level of window comparator (O/OI)	Set range, {Min.-limit level (b061) + hysteresis width (b062)x2} to 100 %	✓	100.	←	←	%
b061 (Windw comp [O/OI] min)	Minimum-limit level of window comparator (O/OI)	Set range, 0 to {Max.-limit level (b060) - hysteresis width (b062)x2}maximum of 100 %	✓	0.	←	←	%
b062 (Windw comp [O/OI] hys)	Hysteresis width of window comparator (O/OI)	Set range, 0 to {Max.-limit level (b060) - Min.-limit level (b061)}/2 % (Maximum of 10%)	✓	0.	←	←	%

"b" Function			Run Mode Edit	Defaults			
Func. Code (WOP)	Name	Description		Initial data	Initial data	Initial data	Unit s
				standard 200/400	CHN 200/400	EU 200/400	
b070 (Discon Level)	Operation level at O/OI disconnection	Set range, 0 to 100%, or "no" (ignore)	✓	no	←	←	-
b078 (Clear kWh data)	Watt-hour clearance data	Two option codes: 00...OFF 01...ON (press STR then clear)	✓	00	←	←	-
b079 (kWh display gain)	Watt-hour display gain	Set range is, 1to1000	✓	1.	←	←	
b082 (Start Frequency)	Start frequency	Sets the starting frequency for the inverter output, range is 0.01 to 9.99 Hz	✓	0.50	←	←	Hz
b083 (Carrier Frequency)	Carrier frequency	Sets the PWM carrier (internal switching frequency), range is 2.0 to 15.0 kHz	✓	2.0	←	←	kH z
b084 (Initialize Mode)	Initialization mode (parameters or trip history)	Select initialized data, four option codes: 00...Initialization disabled 01...Clears Trip history 02...Initializes all Parameters 03...Clears Trip history and initializes all parameters	✗	00	←	←	-
b085 (Initial data select)	Country for initialization	Select default parameter values for country on initialization, two option codes: 00...Mode 0 01...Mode 1 03...Mode 3	✗	00	03	01	-
b086 (FQ scale factor)	Frequency scaling conversion factor	Specify a constant to scale the displayed frequency for d007 monitor, range is 0.01 to 99.99	✓	1.00	←	←	-
b087 (STOP key enable)	STOP key enable	Select whether the STOP key on the keypad is enabled, three option codes: 00...Enabled 01...Disabled always 02... Disabled for stop	✓	00	←	←	-
b088 (Restart after FRS)	Restart mode after FRS	Selects how the inverter resumes operation when free-run stop (FRS) is cancelled, two options: 00...Restart from 0Hz 01...Restart from frequency detected from real speed of motor (freq. matching)	✓	00	←	←	-

Chapter 13 Option

"b" Function			Run Mode Edit	Defaults			
Func. Code (WOP)	Name	Description		Initial data	Initial data	Initial data	Units
				standard	CHN	EU	
			200/400	200/400	200/400		
b089 (Auto.Carrier reduce)	Automatic carrier frequency reduction	Three option codes: 00...Disabled 01...Enabled, depending on the output current 02...Enabled, depending on the heat-sink temperature	✗	00	←	←	–
b091 (Stop mode select)	Stop mode selection	00(Dec and Stop) / 01(FRS)	✓	00	←	←	–
b094 (Initial target data)	Initialization target data setting	00(ALL parameters)/ 01(expect terminal andcommunication data)	✗	00	←	←	–
b100 (Free V/F -F1)	Free V/F setting, freq.1	Set range, 0 ~ value of b102	✗	0.	←	←	Hz
b101 (Free V/F -V1)	Free V/F setting, voltage.1	Set range, 0.0 ~ 300.0V	✗	0.0	←	←	V
b102 (Free V/F -F2)	Free V/F setting, freq.2	Set range, value of b100 ~b104	✗	0.	←	←	Hz
b103 (Free V/F -V2)	Free V/F setting, voltage.2	Set range, 0.0 ~ 300.0V	✗	0.0	←	←	V
b104 (Free V/F -F3)	Free V/F setting, freq.3	Set range, value of b102 ~b106	✗	0.	←	←	Hz
b105 (Free V/F -V3)	Free V/F setting, voltage.3	Set range, 0.0 ~ 300.0V	✗	0.0	←	←	V
b106 (Free V/F -F4)	Free V/F setting, freq.4	Set range, value of b104 ~b108	✗	0.	←	←	Hz
b107 (Free V/F -V4)	Free V/F setting, voltage.4	Set range, 0.0 ~ 300.0V	✗	0.0	←	←	V
b108 (Free V/F -F5)	Free V/F setting, freq.5	Set range, value of b108~ b110	✗	0.	←	←	Hz
b109 (Free V/F -V5)	Free V/F setting, voltage.5	Set range, 0.0 ~ 300.0V	✗	0.0	←	←	V
b110 (Free V/F -F6)	Free V/F setting, freq.6	Set range, value of b108 b112	✗	0.	←	←	Hz
b111 (Free V/F -V6)	Free V/F setting, voltage.6	Set range, 0.0 ~ 300.0V	✗	0.0	←	←	V

"b" Function			Run Mode Edit	Defaults			
Func. Code (WOP)	Name	Description		Initial data	Initial data	Initial data	Units
				standard	CHN	EU	
			200/400	200/400	200/400		
b112 (Free V/F -F7)	Free V/F setting, freq.7	Set range, b110~ 400	✗	0.	←	←	Hz
b113 (Free V/F -V7)	Free V/F setting, voltage.7	Set range, 0.0 ~ 300.0V	✗	0.0	←	←	V
b130 (Over-V supp.select)	Deceleration overvoltage suppression enable	00...Disabled 01...Enabled 02...Enabled with accel. 03...when CONST/DEC	✓	00	←	←	-
b131 (Over-V supp.level)	Decel. overvolt. suppress level	DC bus voltage of suppression. Range is: 200V class...330 to 390 400V class...660 to 780	✓	360/ 720	←	←	V
b132 (Over-V supp.const)	Decel. overvolt. suppress const.	Accel. rate when b130=02. Set range: 0.10 ~ 30.00 seconds.	✓	1.00	←	←	s
b133 (Over-V supp.P-gain)	Decel. overvolt. suppress proportional gain	Proportional gain when b130=01. Range is: 0.00 to 5.00	✓	0.20	←	←	-
b134 (Over-V supp.I-gain)	Decel. overvolt. suppress integral time	Integration time when b130=01. Range is: 0.0 to 150.0 seconds.	✓	1.0	←	←	s
b150 (Disp.ex.ope connected)	Display ex.operator connected	When an external operator is connected via RS-422 port, the built-in display is locked and shows only one "d" parameter configured in: 001 ~ 050	✓	001	←	←	-
b160 (1st data of d050)	1st parameter of Dual Monitor	Set any two "d" parameters in b160 and b161, then they can be monitored in d050. The two parameters are switched by up/down keys. Set range: 001 ~ 018	✓	001	←	←	-
b161 (2nd data of d050)	2nd parameter of Dual Monitor		✓	002	←	←	-
b163 (FQ set in monitor)	Frequency set in monitoring	Two option codes: 00...Freq. set disabled 01...Freq. set enabled	✓	01	←	←	-
b164 (Auto return init.disp)	Automatic return to the initial display	10 min. after the last key operation, display returns to the initial parameter set by b038. Two option codes: 00...Disable 01...Enable	✓	00	←	←	-

Chapter 13 Option

"b" Function			Run Mode Edit	Defaults			
Func. Code (WOP)	Name	Description		Initial data	Initial data	Initial data	Unit s
				standard 200/400	CHN 200/400	EU 200/400	
b165 (Ex.ope comm loss act)	Ex. operator com. loss action	Five option codes: 00...Trip 01...Trip after deceleration to a stop 02...Ignore 03...Coasting (FRS) 04...Decelerates to a stop	✓	02	←	←	–
b166 (Data R/W select)	Data Read/Write select	00... Read/Write OK 01... Protected	✓	00	←	←	–
b180 (Initialize trigger)	Initialization trigger (*)	This is to perform initialization by parameter input with b084, b085 and b094. Two option codes: 00...Initialization disable 01...Perform initialization	✗	00	←	←	–

"C" Function			Run Mode Edit	Defaults			
Func. Code (WOP)	Name	Description		Initial data	Initial data	Initial data	Units
				standard	CHN	EU	
			200/400	200/400	200/400		
C001 (Input [1] Function)	Input [1] function	Select input terminal [1] function, 34 options (see next section)	✓	00 [FW]	←	←	–
C002 (Input [2] Function)	Input [2] function	Select input terminal [2] function, 34 options (see next section)	✓	01 [RV]	←	←	–
C003 (Input [3] Function)	Input [3] function	Select input terminal [3] function, 34 options (see next section)	✓	02 [CF1]	←	←	–
C004 (Input [4] Function)	Input [4] function	Select input terminal [4] function, 34 options (see next section)	✓	03 [CF2]	←	←	–
C005 (Input [5] Function)	Input [5] function	Select input terminal [5] function, 34 options (see next section)	✓	18 [RS]	←	←	–
C011 (Input [1] activ. state)	Input [1] active state	Select logic conversion, two option codes: 00...normally open [NO] 01...normally closed [NC]	✓	00	←	←	–
C012 (Input [2] activ. state)	Input [2] active state		✓	00	←	←	–
C013 (Input [3] activ. state)	Input [3] active state		✓	00	←	←	–
C014 (Input [4] activ. state)	Input [4] active state		✓	00	←	←	–
C015 (Input [5] activ. state)	Input [5] active state		✓	00	←	←	–
C021 (Output [11] function)	Output [11] function	27 programmable functions available for logic (discrete) outputs (see next section)	✓	01 [FA1]	←	←	–
C026 (Alarm relay Function)	Alarm relay function	27 programmable functions available for logic (discrete) outputs (see next section)	✓	05 [AL]	←	←	–

Chapter 13 Option

"C" Function			Run Mode Edit	Defaults			
Func. Code (WOP)	Name	Description		Initial data standard 200/400	Initial data CHN 200/400	Initial data EU 200/400	Units
C027 ([FM] Function)	[FM] terminal selection (Pulse/PWM output)	9 programmable functions: 00...Output frequency (PWM) 01...Output current (PWM) 03...Output frequency (Pulse train) 04...Output voltage (PWM) 05...Input power (PWM) 06...Electronic thermal load ratio (PWM) 07...LAD frequency (PWM) 08...Output current (Pulse train) 10...Heat sink temperature (PWM)	✓	07	←	←	-
C030 (Digital I Ref.)	Digital current monitor reference value	Current with digital current monitor output at 1,440Hz Range is 20%~200% of rated current	✓	Rated current	←	←	A
C031 (Output [11] actv.state)	Output [11] active state	Select logic conversion, two option codes: 00...normally open [NO]	✓	00	←	←	-
C036 (Alarm RLY active state)	Alarm relay active state	01...normally closed [NC]	✓	01	←	←	-
C038 (LOC out mode select)	Output mode of low current detection	Two option codes: 00...During acceleration, deceleration and constant speed 01...During constant speed only	✓	01	←	←	-
C039 (LOC out level)	Low current detection level	Set the level of low load detection, range is 0.00 to 2.00*inverter rated current	✓	Rated current	←	←	A
C040 (Overload warn mode)	Output mode of overload warning	Two option codes: 00...During accel., decel. and constant speed 01...During constant speed only	✓	01	←	←	-
C041 (Overload warn level)	Overload warning level	Sets the overload warning signal level between 0% and	✓	Rated current x 1.15	←	←	A

"C" Function			Run Mode Edit	Defaults			
Func. Code (WOP)	Name	Description		Initial data	Initial data	Initial data	Units
				standard 200/400	CHN 200/400	EU 200/400	
C241 (Overload warn level-M2)	Overload warning level, 2 nd motor	200% (from 0 to two time the rated current of the inverter)	✓	Rated current x 1.15	←	←	A
C042 (FQ arrive accel.1)	Frequency arrival setting for acceleration	Sets the frequency arrival setting threshold for the output frequency during acceleration, range is 0.00 to 400.00 Hz	✓	0.00	←	←	Hz
C043 (FQ arrive decel.1)	Frequency arrival setting for deceleration	Sets the frequency arrival setting threshold for the output frequency during deceleration, range is 0.00 to 400.00 Hz	✓	0.00	←	←	Hz
C044 (PID deviation)	PID deviation level	Sets the allowable PID loop error magnitude (absolute value), SP-PV, range is 0.0 to 100%	✓	3.0	←	←	%
C052 (PID FBV high limit)	PID FBV output high limit	When the PV exceeds this value, the PID loop turns OFF the PID second stage output, range is 0.0 to 100%	✓	100.0	←	←	%
C053 (PID FBV low limit)	PID FBV output low limit	When the PV goes below this value, the PID loop turns ON the PID second stage output, range is 0.0 to 100%	✓	0.0	←	←	%
C061 (E.Thermal warning)	Electronic thermal warning level	Set range is 0 to 100% Setting 0 means disabled.	✓	90	←	←	%
C063 (0Hz detection level)	Zero speed detection level	Set range is 0.00 to 100.00Hz	✓	0.00	←	←	Hz
C064 (Heatsink warning)	Heat sink overheat warning	Set range is 0 to 110 °C	✓	100.	←	←	°C
C070 (Comm.Select)	Selection of OPE/Modbus	00 (OPE) / 01 (Modbus)	✗	00	←	←	-
C071 (Comm.baud rate)	Communication speed	Five option codes: 04...4,800 bps 05...9,600 bps 06...19,200 bps 07...38,400 bps	✓	05	←	←	bps
C072 (Modbus address)	Modbus address	Set the address of the inverter on the network. Range is 1 to 247	✓	1.	←	←	-

Chapter 13 Option

"C" Function			Run Mod e Edit	Defaults			
Func. Code (WOP)	Name	Description		Initial data	Initial data	Initial data	Unit s
				standard 200/400	CHN 200/400	EU 200/400	
C074 (Parity)	Communication parity	Three option codes: 00...No parity 01...Even parity 02...Odd parity	✓	00	←	←	–
C075 (Stop bit)	Communication stop bit	Two option codes: 01...1 bit 02...2 bit	✓	1	←	←	–
C076 (Comm.error mode)	Communication error select	Selects inverter response to communications error. Five options: 00...Trip 01...Decelerate to a stop and trip 02...Disable 03...Free run stop (coasting) 04...Decelerates to a stop	✓	02	←	←	–
C077 (Comm.timeout)	Communication error time-out	Sets the communications watchdog timer period. Range is 0.00 to 99.99 seconds. 0.00= disabled	✓	0.00	←	←	s
C078 (Comm.wait time)	Communication wait time	Time the inverter waits after receiving a message before it transmits. Range is 0. to 1000. m seconds.	✓	0.	←	←	ms
C081 ([O/OI] input adj.)	O/OI input span calibration	Scale factor between the external frequency command on terminals L–O /OI(voltage/current input) and the frequency output, range is 0.0 to 200.0%	✓	100.0	←	←	%
C091 (Debug mode select)	Debug mode enable *	Displays debug parameters. Two option codes: 00...Disable 01...Enable <Do not set> (for factory use)	✓	00	←	←	–

"C" Function			Run Mode Edit	Defaults			
Func. Code (WOP)	Name	Description		Initial data	Initial data	Initial data	Units
				standard 200/400	CHN 200/400	EU 200/400	
C101 (UP/DWN memory mode)	Up/Down memory mode selection	Controls speed setpoint for the inverter after power cycle. Two option codes: 00...Clear last frequency (return to default frequency F001) 01...Keep last frequency adjusted by UP/DWN	✓	00	←	←	–
C102 (Reset mode select)	Reset selection	Determines response to Reset input [RS]. Three option codes: 00...Cancel trip state at input signal ON transition, stops inverter if in Run Mode 01...Cancel trip state at signal OFF transition, stops inverter if in Run Mode 02...Cancel trip state at input ON transition, no effect if in Run Mode	✓	00	←	←	–
C103 (Restart after reset)	Restart mode after reset	Determines the restart mode after reset is given, two option codes: 00...Start with 0 Hz 01...Start with freq. matching	✓	00	←	←	–
C104 (UP/DWN clear mode)	UP/DWN clear mode	Freq. set value when UDC signal is given to the input terminal, two option codes: 00...0 Hz 01...Original setting (in the memory at power on)	✓	00	←	←	–
C105 (FM gain adjust)	FM gain adjustment	Set range is 50 to 200%	✓	100.	←	←	%
C130 (Output [11] ON delay)	Output [11] on delay	Set range is 0.0 to 100.0 seconds.	✓	0.0	←	←	s
C131 (Output [11] OFF delay)	Output [11] off delay		✓	0.0	←	←	s

Chapter 13 Option

"C" Function			Run Mod e Edit	Defaults			
Func. Code (WOP)	Name	Description		Initial data	Initial data	Initial data	Unit s
				standard 200/400	CHN 200/400	EU 200/400	
C140 (Alarm-RLY ON delay)	Relay output on delay	Set range is 0.0 to 100.0 seconds.	✓	0.0	←	←	s
C141 (Alarm-RLY OFF delay)	Relay output off delay		✓	0.0	←	←	s
C142 (Log.out 1 operand A)	Logic output 1 operand A	All the programmable functions available for logic (discrete) outputs except LOG1 , no	✓	00	←	←	-
C143 (Log.out 1 operand B)	Logic output 1 operand B		✓	00	←	←	-
C144 (Log.out 1 operator)	Logic output 1 operator	Applies a logic function to calculate [LOG] output state, Three options: 00...[LOG] = A AND B 01...[LOG] = A OR B 02...[LOG] = A XOR B	✓	00	←	←	-
C151 (Button sens.)	Button sensitivity selection	0 to 250 / no	✓	10	←	←	-
C152 (Scroll sens.)	Scroll sensitivity selection	1 to 20	✓	10	←	←	-
C155 (Ground fault set)	Ground fault detection	00(OFF) / 01(ON)	✓	01	←	←	-
C157 (Out phase-loss set)	Out phase loss detection	00(OFF) / 01(ON)	✓	00	←	←	-
C160 (Input [1] resp.time)	Input [1] response time	Sets response time of each input terminal, set range: 0□(x 2 [ms]) to 200□(x 2 [ms]) (0 to 400 [ms])	✓	1.	←	←	-
C161 (Input [2] resp.time)	Input [2] response time		✓	1.	←	←	-
C162 (Input [3] resp.time)	Input [3] response time		✓	1.	←	←	-
C163 (Input [4] resp.time)	Input [4] response time		✓	1.	←	←	-
C164 (Input [5] resp.time)	Input [5] response time		✓	1.	←	←	-
C169 (Multi-spd determ.time)	Multistage speed determination time	Set range is 0. to 200. (x 10ms)	✓	0.	←	←	ms

Input Function Summary Table – This table shows all thirty-four intelligent input functions at a glance. Detailed description of these functions, related parameters and settings, and example wiring diagrams are in “Using Intelligent Input Terminals” on page 4-8.

Input Function Summary Table				
Option Code	Terminal Symbol	Function Name	Description	
00	FW	FORWARD Run/Stop	ON	Inverter is in Run Mode, motor runs forward
			OFF	Inverter is in Stop Mode, motor stops
01	RV	Reverse Run/Stop	ON	Inverter is in Run Mode, motor runs reverse
			OFF	Inverter is in Stop Mode, motor stops
02	CF1 *1	Multi-speed Select, Bit 0 (LSB)	ON	Binary encoded speed select, Bit 0, logical 1
			OFF	Binary encoded speed select, Bit 0, logical 0
03	CF2	Multi-speed Select, Bit 1	ON	Binary encoded speed select, Bit 1, logical 1
			OFF	Binary encoded speed select, Bit 1, logical 0
04	CF3	Multi-speed Select, Bit 2(MSB)	ON	Binary encoded speed select, Bit 2, logical 1
			OFF	Binary encoded speed select, Bit 2, logical 0
06	JG	Jogging	ON	Inverter is in Run Mode, output to motor runs at jog parameter frequency
			OFF	Inverter is in Stop Mode
07	DB	External DC braking	ON	DC braking will be applied during deceleration
			OFF	DC braking will not be applied
08	SET	Set (select) 2nd Motor Data	ON	The inverter uses 2nd motor parameters for generating frequency output to motor
			OFF	The inverter uses 1st (main) motor parameters for generating frequency output to motor
09	2CH	2-stage Acceleration and Deceleration	ON	Frequency output uses 2nd-stage acceleration and deceleration values
			OFF	Frequency output uses standard acceleration and deceleration values
11	FRS	Free-run Stop	ON	Causes output to turn OFF, allowing motor to free run (coast) to stop
			OFF	Output operates normally, so controlled deceleration stop motor
12	EXT	External Trip	ON	When assigned input transitions OFF to ON, inverter latches trip event and displays <input type="checkbox"/> <input type="checkbox"/> <input type="checkbox"/> <input type="checkbox"/>
			OFF	No trip event for ON to OFF, any recorded trip events remain in history until reset
13	USP	Unattended Start Protection	ON	On power up, the inverter will not resume a Run command (mostly used in the US)
			OFF	On power up, the inverter will resume a Run command that was active before power loss
15	SFT	Software Lock	ON	The keypad and remote programming devices are prevented from changing parameters
			OFF	The parameters may be edited and stored
18	RS	Reset Inverter	ON	The trip condition is reset, the motor output is turned OFF, and power up reset is asserted
			OFF	Normal power-ON operation
20	STA	Start (3-wire interface)	ON	Starts the motor rotation
			OFF	No change to present motor status
21	STP	Stop (3-wire interface)	ON	Stops the motor rotation
			OFF	No change to present motor status
22	F/R	FWD, REV (3-wire interface)	ON	Selects the direction of motor rotation: ON = FWD. While the motor is rotating, a change of F/R will start a deceleration, followed by a change in direction
			OFF	Selects the direction of motor rotation: OFF = REV. While the motor is rotating, a change of F/R will start a deceleration, followed by a change in direction

Chapter 13 Option

Input Function Summary Table				
Option Code	Terminal Symbol	Function Name	Description	
23	PID	PID Disable	ON	Temporarily disables PID loop control. Inverter output turns OFF as long as PID Enable is active (□□□□=□□)
			OFF	Has no effect on PID loop operation, which operates normally if PID Enable is active (□□□□=□□)
24	PIDC	PID Reset	ON	Resets the PID loop controller. The main consequence is that the integrator sum is forced to zero
			OFF	No effect on PID controller
27	UP	Remote Control UP Function (motorized speed pot.)	ON	Accelerates (increases output frequency) motor from current frequency
			OFF	Output to motor operates normally
28	DWN	Remote Control Down Function (motorized speed pot.)	ON	Decelerates (decreases output frequency) motor from current frequency
			OFF	Output to motor operates normally
29	UDC	Remote Control Data Clearing	ON	Clears the UP/DWN frequency memory by forcing it to equal the set frequency parameter F001. Setting □□□□ must be set=□□ to enable this function to work
			OFF	UP/DWN frequency memory is not changed
31	OPE	Operator Control	ON	Forces the source of the output frequency setting □□□□ and the source of the Run command □□□□ to be from the digital operator
			OFF	Source of output frequency set by □□□□ and source of Run command set by □□□□ is used
32	SF1	Multi-speed Select,	ON	Bit encoded speed select, Bit 1, logical 1
		Bit operation Bit 1	OFF	Bit encoded speed select, Bit 1, logical 0
33	SF2	Multi-speed Select,	ON	Bit encoded speed select, Bit 2, logical 1
		Bit operation Bit 2	OFF	Bit encoded speed select, Bit 2, logical 0
34	SF3	Multi-speed Select,	ON	Bit encoded speed select, Bit 3, logical 1
		Bit operation Bit 3	OFF	Bit encoded speed select, Bit 3, logical 0
39	OLR	Overload Restriction Source Changeover	ON	Perform overload restriction
			OFF	Normal operation
50	ADD	ADD frequency enable	ON	Adds the □□□□ (add frequency) value to the output frequency
			OFF	Does not add the □□□□ value to the output frequency
51	F-TM	Force Terminal Mode	ON	Force inverter to use input terminals for output frequency and Run command sources
			OFF	Source of output frequency set by □□□□ and source of Run command set by □□□□ is used
53	KHC	Clear watt-hour data	ON	Clear watt-hour data
			OFF	No action
65	AHD	Analog command hold	ON	Analog command is held
			OFF	Analog command is not held
83	HLD	Retain output frequency	ON	Retain the current output frequency
			OFF	No retention
84	ROK	Permission of Run command	ON	Run command permitted
			OFF	Run command is not permitted
86	DISP	Display limitation	ON	Only a parameter configured in □□□□ is shown
			OFF	All the monitors can be shown
no	no	No function	ON	(input ignored)
			OFF	(input ignored)

Output Function Summary Table – This table shows all functions for the logical outputs (terminals [11] and [AL]) at a glance. Detailed descriptions of these functions, related parameters and settings, and example wiring diagrams are in “Using Intelligent Output Terminals” in chapter 4.

Output Function Summary Table				
Option Code	Terminal Symbol	Function Name	Description	
00	RUN	Run Signal	ON	When the inverter is in Run Mode
			OFF	When the inverter is in Stop Mode
01	FA1	Frequency Arrival Type 1–Constant Speed	ON	When output to motor is at the set frequency
			OFF	When output to motor is OFF, or in any acceleration or deceleration ramp
02	FA2	Frequency Arrival Type 2–Over frequency	ON	When output to motor is at or above the set freq., even if in accel (□□□□) or decel (□□□□) ramps
			OFF	When output to motor is OFF, or at a level below the set frequency
03	OL	Overload Advance Notice Signal 1	ON	When output current is more than the set threshold (□□□□) for the overload signal
			OFF	When output current is less than the set threshold for the deviation signal
04	OD	Output Deviation for PID Control	ON	When PID error is more than the set threshold for the deviation signal
			OFF	When PID error is less than the set threshold for the deviation signal
05	AL	Alarm Signal	ON	When an alarm signal has occurred and has not been cleared
			OFF	When no alarm has occurred since the last cleaning of alarm(s)
06	FA3	Frequency Arrival Type 3–Set frequency	ON	When output to motor is at the set frequency, during accel (□□□□) and decel (□□□□).
			OFF	When output to motor is OFF, or is not at a level of the set frequency
09	UV	Undervoltage	ON	Inverter is in Undervoltage
			OFF	Inverter is not in Undervoltage
11	RNT	Run Time Expired	ON	Total running time of the inverter exceeds the specified value
			OFF	Total running time of the inverter does not exceed the specified value
12	ONT	Power ON time Expired	ON	Total power ON time of the inverter exceeds the specified value
			OFF	Total power ON time of the inverter does not exceed the specified value
13	THM	Thermal Warning	ON	Accumulated thermal count exceeds the □□□□ set value
			OFF	Accumulated thermal count does not exceed the □□□□ set value
21	ZS	Zero Hz Speed Detection Signal	ON	Output frequency falls below the threshold specified in □□□□
			OFF	Output frequency is higher than the threshold specified in □□□□
27	ODc	Analog Voltage Input Disconnect Detection	ON	When the [O] input value < □□□□ setting (signal loss detected)
			OFF	When no signal loss is detected
31	FBV	PID Second Stage Output	ON	Transitions to ON when the inverter is in RUN Mode and the PID Process Variable (PV) is less than the Feedback Low Limit (□□□□)
			OFF	Transitions to OFF when the PID Process Variable (PV) exceeds the PID High Limit (□□□□), and transitions to OFF when the inverter goes from Run

Output Function Summary Table				
Option Code	Terminal Symbol	Function Name	Description	
				Mode to Stop Mode
32	NDc	Network Disconnect Detection	ON	When the communications watchdog timer (period specified by □□□□) has time out
			OFF	When the communications watchdog timer is satisfied by regular communications activity
33	LOG	Logic Output Function 1	ON	When the Boolean operation specified by □□□□ has a logical "1" result
			OFF	When the Boolean operation specified by □□□□ has a logical "0" result
41	FR	Starting Contact Signal	ON	Either FW or RV command is given to the inverter
			OFF	No FW or RV command is given to the inverter, or both are given to the inverter
42	OHF	Heat Sink Overheat Warning	ON	Temperature of the heat sink exceeds a specified value (□□□□)
			OFF	Temperature of the heat sink does not exceed a specified value (□□□□)
43	LOC	Low load detection	ON	Motor current is less than the specified value (□□□□)
			OFF	Motor current is not less than the specified value (□□□□)
50	IRDY	Inverter Ready Signal	ON	Inverter can receive a run command
			OFF	Inverter cannot receive a run command
51	FWR	Forward Rotation	ON	Inverter is driving the motor in forward direction
			OFF	Inverter is not driving the motor in forward direction
52	RVR	Reverse Rotation	ON	Inverter is driving the motor in reverse direction
			OFF	Inverter is not driving the motor in reverse direction
53	MJA	Major Failure Signal	ON	Inverter is tripping with major failure
			OFF	Inverter is normal, or is not tripping with major failure
54	WCO	Window Comparator for Analog Voltage Input	ON	Analog voltage input value is inside of the window comparator
			OFF	Analog voltage input value is outside of the window comparator
58	FREF	Frequency Command Source	ON	Frequency command is given from the operator
			OFF	Frequency command is not given from the operator
59	REF	Run Command Source	ON	Run command is given from the operator
			OFF	Run command is not given from the operator
60	SETM	2 nd Motor Selection	ON	2 nd motor is being selected
			OFF	2 nd motor is not being selected
no	no	Not used	ON	-
			OFF	-

"H" Function			Run Mode Edit	Defaults			
Func. Code (WOP)	Name	Description		Initial data	Initial data	Initial data	Units
				standard	CHN	EU	
			200/400	200/400	200/400		
H003 (Motor capacity)	Motor capacity	Twelve selections: 0.10/0.20/0.40/0.55/0.75/1.10/1.50/2.20/3.00/3.70/4.00/5.50	✗	Specified by the capacity of each inverter model	←	←	kW
H203 (Motor capacity-M2)	Motor capacity, 2 nd motor		✗		←	←	kW
H004 (Motor poles)	Motor poles setting	Five selections: 2 / 4 / 6 / 8	✗	4	←	←	poles
H204 (Motor poles-M2)	Motor poles setting, 2 nd motor		✗	4	←	←	poles
H006 (M.stabil.const)	Motor stabilization constant	Motor constant (factory set), range is 0 to 255	✓	100.	←	←	–
H206 (M.stabil.const-M2)	Motor stabilization constant, 2 nd motor		✓	100.	←	←	–

13.2 Top cover for exclusive use of NE-S1series : NES1-FFM-M

- Prepared exclusive top cover NES1-FFM-M (Afterward FFM) to improve usability of the inverter. The applicable models are as follows. There are respective effects.
 - Effect to improve derating properties
 - Effect to improve Capacitor life
 - Effect not to let dust invade it from the upper part
 - Effect to reduce an installation area at the time of plural mount installation

Applicable model : NES1-015~022SB/LB,007~040HB

Note) Please do not be attached to the inverter which is not an applicable model. There might be an injury, the fire. In addition, cause the inverter discarding.

13.2.1 Mounting method

- Because mounting method varies according to inverter, please be careful.
 - NES1-015~022SB/LB,022HB,040HB
 - NES1-015HB
 - NES1-007HB

When the inverter which I purchased is included in ①, fit FFM in the cover upper surface of the main body of inverter, and, please use it.

When the inverter which I purchased is included in ②, After having removed (shaded area) surgically in nippers for back side tang of FFM of figure 2, fit FFM in the cover upper surface of the main body of inverter, and, please use it.

When the inverter which I purchased is included in ③, After having removed (shaded area) surgically in nippers for back side tang of FFM of figure 2 and 3, fit FFM in the cover upper surface of the main body of inverter, and, please use it.

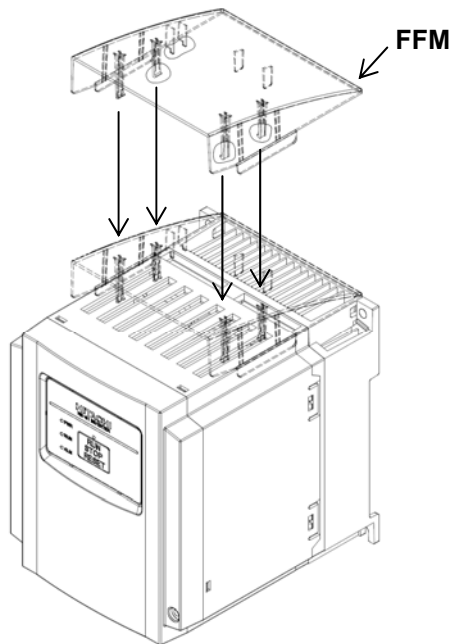

Figure1 Mounting method of FFM

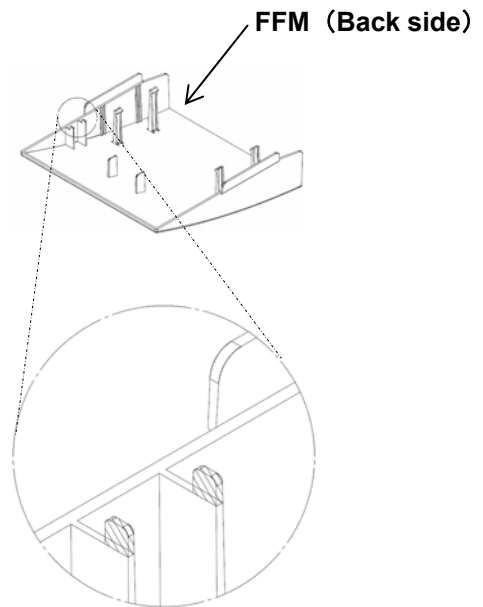

Figure 2 Part (shaded area) to remove surgically

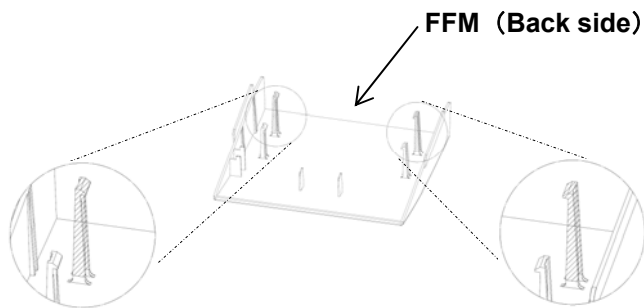

Figure3 Part (shaded area) to remove surgically

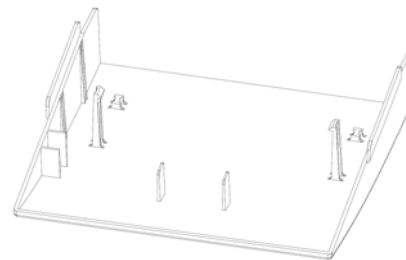

Figure 4 After part (shaded area) to remove surgically

13.2.2 Improvement of the derating

• Derating properties are improved by attaching optional FFM to an applicable model. Neither applicable model needs the derating of the carrier frequency and the current derating at ambient temperature 50°C. The detail refers to figure 5 ,6 and figure 7

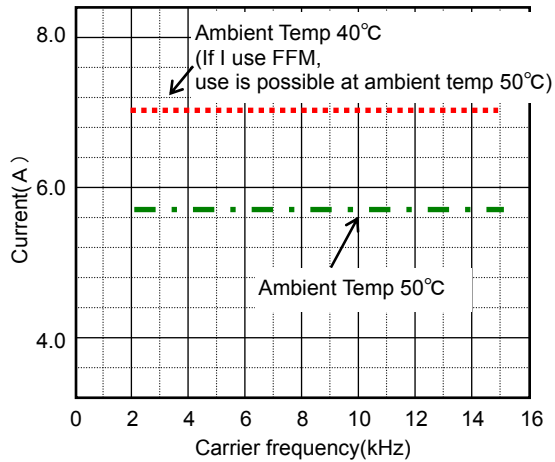

Figure5. Derating of NES1-015SB

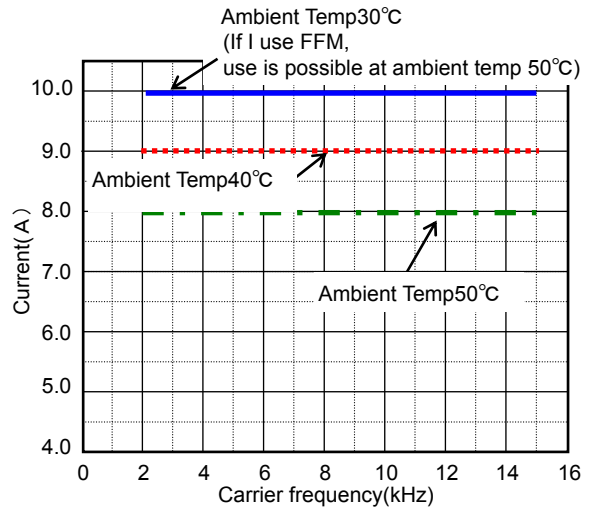

Figure6. Derating of NES1-022SB

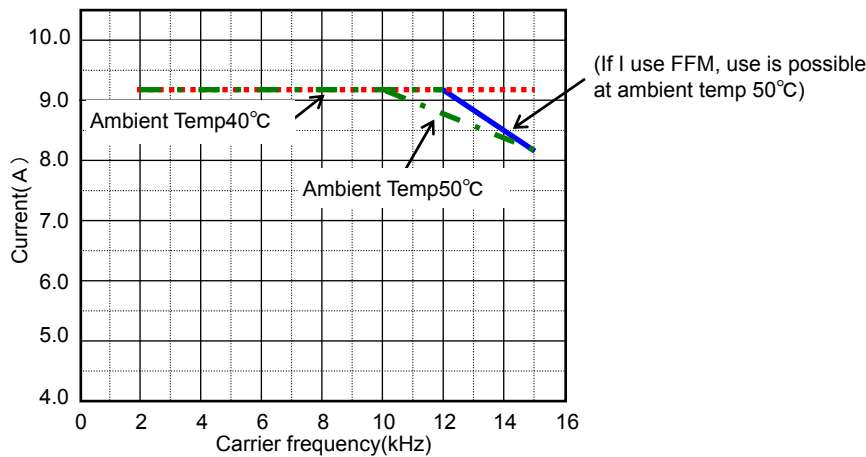

Figure7. Derating of NES1-040HB

13.2.3 Capacitor life improvement

• Bus capacitor life doubles approximately when I attach optional FFM to an applicable model. The detail refers to figure 8

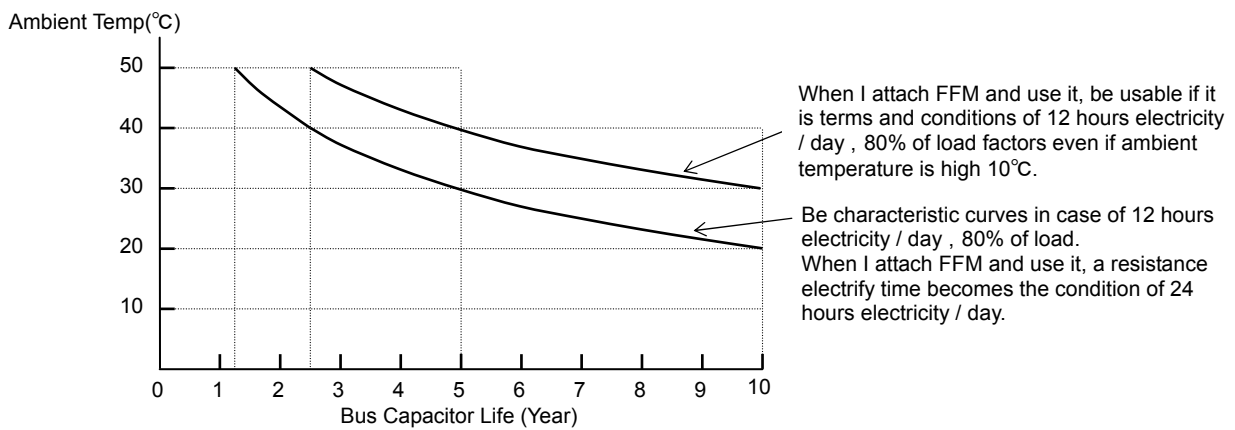

Figure 8. Carve of Bus Capacitor Life

13.2.4 Reduction of the dust invades

• Because a top opening becomes the window shade construction as for the inverter of the NE-S1 series, it is in the structure that direct, the dust from the top is hard to invade the products inside.

The dust from the top becomes hard to invade the inverter inside more by attaching optional FFM to an applicable model.

The detail refers to figure 9



Figure9.FFM installation state

13.2.5 Reduction of the inverter installation space area

At the time of the inverter installation, space more than above or the below 10cm is necessary not to disturb ventilation.

However, please secure only 2cm that is measure of FFM because be exhausted by the front when optional FFM to an applicable model is attached. (Refer to Figure 10)

In this case, please keep the clearance from the front panel such as cabinet door. (Refer to Figure 11)
 In addition, as well as a case to set up inverter lengthwise, space more than 10cm becomes needless if a wiring duct in the upper part is installed.

Therefore, can reduce requisite space at the time of the installation. (Refer to Figure 12)

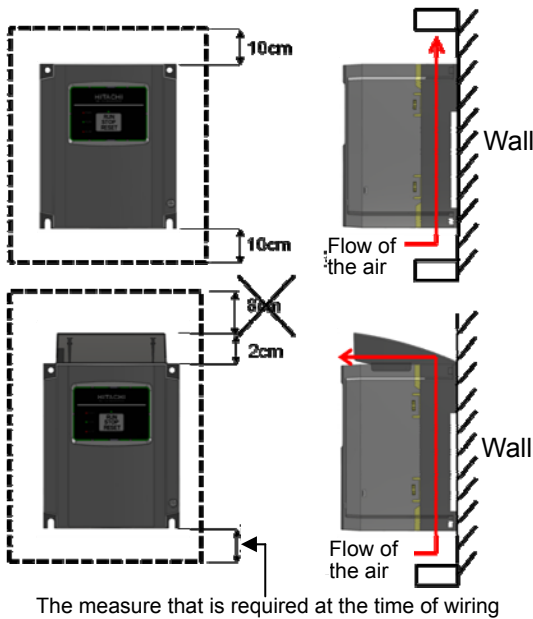

Figure10. Reduction of the inverter upper part space

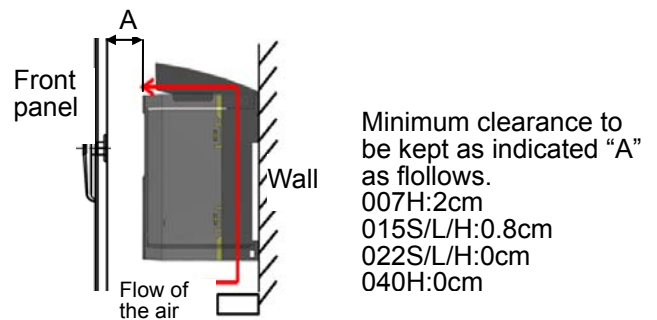

Figure11. Minimum clearance from front panel

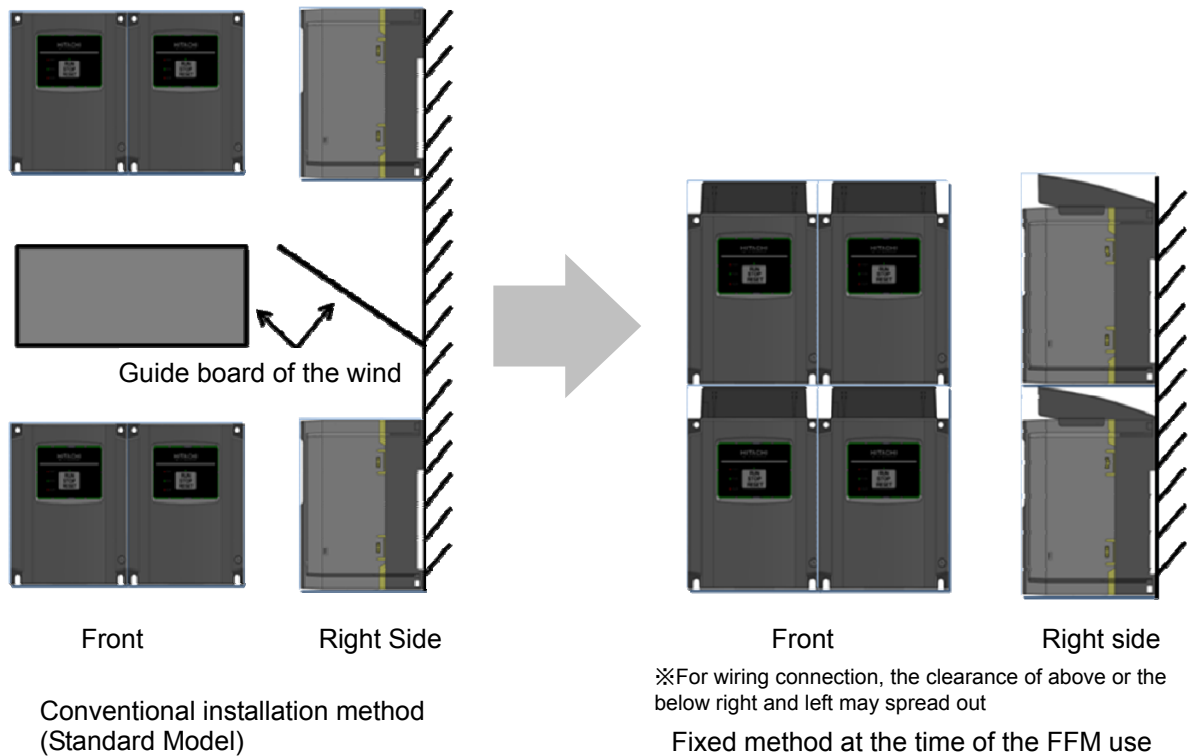

Figure12. Lower tooth-space if I installed inverter many several

Appendix



.

Appendix AAppendix A- 1

Appendix-A Disassembly method of NES1-OP

(1) After having removed a Front Cover, remove two places of screws.



Remove two places of screws.



(2) Pick up the side of the operator cover, and remove a NES1-OP..

*Take it off the inverter right side by all means if I exclude a NES1-OP.

Pick up the point that I ordered in a figure, and flatter PCB, and take off two places of nails of the operator to open it outside of inverter (cf. photograph A,B). If the nail of the right side surface comes off, remove the left side surface equally next (cf. photograph C,D).

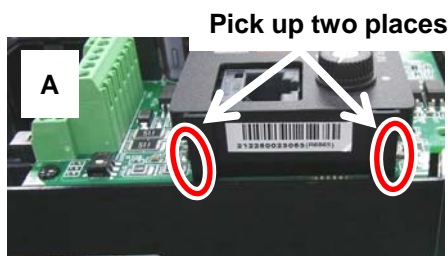

Take off two places of picks of NES1-OPE to open it outside of inverter



The condition that two places of nails of NES1-OPE were off.

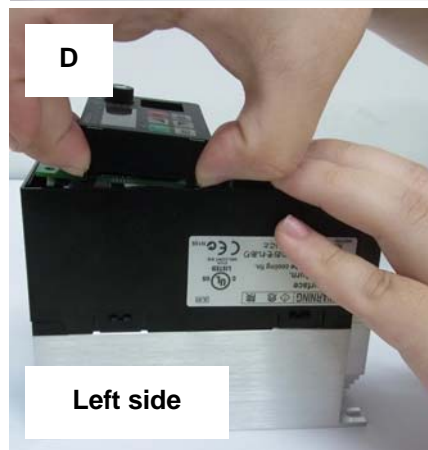
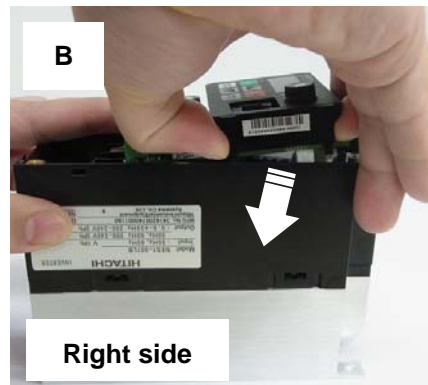

A

acceleration/deceleration patterns	7-30
acceleration/deceleration times.....	7-8
acceleration curve constant	7-30
acceleration time.....	7-8
acceleration (2) time	7-29
acceleration hold time	7-27
acceleration hold frequency	7-27
a contact	7-12, 7-14
ADD	7-32
ADD direction select	7-32
AHD	7-17
AL	7-60
alarm lamp	6-4, 6-5
allowable under-voltage power failure time	7-51
analog command holding	7-17
analog input	7-16
analog input filter.....	7-16
automatic carrier frequency reduction.....	7-67
automatic return to the initial display.....	7-47
automatic torque boost	7-22
AVR.....	7-9
AVR filter time constant.....	7-9
AVR voltage select.....	7-9
AVR deceleration gain	7-9

B

basic display	7-49
base frequency	7-9
b contact	7-12, 7-14
binary operation	7-28
bit operation	7-28

C

capacitor life warning	11-5
carrier frequency	7-11
CF1, CF2, CF3.....	7-28
CM2	5-6
charge lamp	3-2, 5-9
communication error select.....	8-4
communication line disconnection signal.....	7-72
constant-torque characteristic (electronic thermal).....	7-62
constant-torque characteristic (VC).....	7-20
control circuit terminal	5-5, 5-12
cumulative power monitoring	7-3
2CH.....	7-29

D

DB.....	7-41
Dc	7-75
DC braking.....	7-41
DC voltage monitoring	7-5
deceleration time setting	7-8
deceleration (2) time setting.....	7-29
deceleration and stopping at power failure	7-58
deceleration curve constant	7-30
deceleration hold time	7-27
deceleration hold frequency	7-27

deceleration overvoltage restraint.....	7-65
derating	12-4
detection of terminal disconnection	7-75
digital current monitoring	7-19
digital current monitor reference value	7-19
digital output frequency	7-19
DISP	7-47
display limitation function.....	7-47
DWN.....	7-32
down key	6-5
dual monitoring.....	7-4
Disassembly method of NES1-OP	Appendix-1

E

earth terminal	5-5, 5-8
electronic thermal	7-61
electronic thermal overload monitoring.....	7-5
electronic thermal warning level setting.....	7-62
EMC	1-5
end-frequency rate	7-18
energy-saver operation.....	7-39
energy-saving mode tuning	7-39
error code	9-3
ESC key	6-5
Ex. operator com. loss action	7-46
EXT	7-66
external DC braking.....	7-42
external dimensions.....	12-2
external trip.....	7-66

F

F/R.....	7-23
F-TM.....	7-7, 7-46
factory default(setting)	7-77
FA1, FA2, FA3	7-68
FBV	7-34
feedback comparison	7-34
forcible operation.....	7-7, 7-45
forcible-terminal operation	7-7, 7-46
forward rotation signal	7-73
FR.....	7-72
FREF	7-76
free setting of electronic thermal characteristic.....	7-62
free V/f characteristic.....	7-21
free-run stop	7-56
frequency addition	7-32
frequency arrival setting for accel.	7-68
frequency arrival setting for decel.....	7-68
frequency arrival signals.....	7-68
frequency limit	7-26
frequency lower limit.....	7-26
frequency matching	7-51
frequency source setting	7-6
frequency to be added.....	7-32
frequency upper limit	7-26
FRS	7-56
function code display restriction.....	7-48
Function-specific display	7-48
fuse size	5-11
FW	7-7
FWR	7-73

Index

H

H terminal 5-5
heat sink overheat warning 7-72
heat sink temperature monitoring 7-3
HLD 7-27
hold down 6-5, 6-10

I

Initial screen selection 7-46
initialization 7-77
initializes all Parameters 7-77
input power display 7-3
input terminal a/b selection 7-12
input terminal response time 7-13
inspection 2-1, 11-1
instantaneous power failure/
under-voltage trip alarm enable 7-52
intelligent input terminal 5-6, 7-12
intelligent input terminal status 7-2
intelligent output terminal 5-6, 7-13
intelligent output terminal status 7-2
intelligent relay output terminal 5-6, 7-14
internal DC braking 7-43
inverted-U-curve acceleration /
deceleration 7-30
IRDY 7-73

J

JG 7-25
jogging command setting 7-25
jump frequency function 7-26

K

KHC 7-3

L

L terminal 5-5
LAD 7-19
LOC 7-73
LOG1 7-71
logical output signal operation 7-71
low-current indication signal 7-73

M

main circuit terminal 5-5
maintenance and inspection 11-1
major failure signal 7-74
maximum frequency 7-11
manual torque boost 7-22
megger testing 11-3
modbus RTU 8-1
MJA 7-74
multispeed select setting 7-28
multistage speed determination time 7-28

N

NDc 7-72
NO/NC 7-12, 7-14
number of retry on over voltage / over

current trip 7-51

O

O/OI terminal 5-5, 7-16
OD 7-37
OHF 7-72
OL 7-63
OLR 7-63
operation time over signal
(RNT)/plug-in time over signal
(ONT) 7-70
OPE 7-45
operator selection for frequency
operation 7-31
output active state 7-14
output current monitoring 7-1
output frequency monitoring 7-1
output frequency setting 7-6
output on delay 7-15
output off delay 7-15
output voltage monitoring 7-3
overcurrent restraint 7-64
overload notice advance signal 7-64
overload restriction 7-63

P

P24 terminal 5-5, 5-12, 5-13
PID function 7-34
PID feedback monitoring 7-1
PIDC 7-37
PID variation range 7-34
PID scale 7-1, 7-35
PID sleep function 7-34, 7-38
PLC terminal 5-5, 5-12, 5-13
power-on time over 7-70
PRG lamp 6-5
program lamp 6-5
programmable controller 5-14
PWR lamp 6-4, 6-5

R

reduced-torque characteristic
(electronic thermal) 7-61
reduced torque characteristic (VP) 7-20
reduced voltage start 7-24
REF 7-76
reset 6-19, 7-55
restart frequency threshold 7-51
restart mode on power failure /
under-voltage trip 7-51
restart with an active matching
frequency 7-54
retry of OV/OC 7-51
retry wait time before motor restart 7-51
reverse rotation signal 7-74
reverse PID action 7-34
RNT 7-70
ROK 7-27
rotation direction monitoring 7-1
rotational direction restriction 7-7
RS 6-19, 7-55
RUN 7-68
RUN key 6-5
RUN LED 6-5
running time over 7-70

RUN / STOP / RESET key	6-4		
run command source setting	7-7		
run command LED	6-5		
Run Mode Edit	7-45		
RV	7-7		
RVR	7-74		
S			
S-curve acceleration / deceleration	7-30		
scaled output frequency monitoring	7-2		
2nd control	7-40		
SET	7-40		
SETM	7-76		
SET key	6-5		
SFT	7-45		
SF1, SF2, SF3	7-28		
side-by-side	4-3		
sink logic	5-13		
software lock	7-45		
source logic	5-13		
specifications	12-1		
STA	7-23		
stabilization constant	7-39		
start/end frequency setting for external analog input	7-18		
start frequency	7-18		
start-frequency rate	7-18		
starting contact signal	7-72		
stop mode selection	7-8		
STP	7-23		
switch for termination resistor	3-2		
T			
termination resistors	8-2		
Thermal warning	7-62		
THM	7-62		
tightening torque	5-12		
3-wire interface operation function	7-23		
torque boost	7-22		
trip	6-19, 7-60		
trip counter	7-4		
trip monitoring	7-4		
troubleshooting	10-1		
2-stage acceleration/deceleration	7-29		
2CH	7-29		
U			
U-curve acceleration / deceleration	7-30		
UDC	7-32		
UL	1-10		
unattended start protection	7-57		
UP	7-32		
UP key	6-5		
UP/DWN	7-32		
USP	7-57		
UV	7-13		
V			
V/f characteristic curve	7-20		
V/f gain setting	7-33		
VC	7-20		
VP 1.7 th power	7-20		
W			
warning display	9-5		
warning monitoring	7-5		
WC	7-75		
window comparator	7-75		
wiring of control circuit terminal	5-12		
withstand voltage test	11-3		
Z			
0Hz detection signal	7-70		
ZS	7-70		