



Power transmission for your success



Operating Instructions

Motor Controller MAE-4Q-5-30



D

PCA 1, 2, 3
Subsidiary
MÄDLER GmbH
Brookstieg 16
D-22145 Stapelfeld
Tel. +49 40-60 04 75 10
hamburg@maedler.de
www.maedler.de

D

PCA 0, 4, 5
Subsidiary
MÄDLER GmbH
Bublitzer Str. 21
D-40599 Düsseldorf
Tel. +49 211-97 47 10
duesseldorf@maedler.de
www.maedler.de

D

PCA 6, 7, 8, 9
Headquarter
MÄDLER GmbH
Tränkestr. 6-8
D-70597 Stuttgart
Tel. +49 711-7 20 95 0
stuttgart@maedler.de
www.maedler.de

A

MÄDLER
Österreich GmbH
Schottenfeldgasse 14/3
A-1070 Wien
Tel. +43 1398 1398-00
info@maedler.at
www.maedler.at

CH

MÄDLER
NORM-ANTRIEB AG
Haldenstr. 14
CH-8245 Feuerthalen
Tel. +41 52 647 40 40
info@maedler.ch
www.maedler.ch

Industrial motor controller for brushed DC motors 24 V DC

Design for output currents up to 5 A

Control with the following functions:

- reversal of direction of rotation
- open-loop speed control (external)
- current limitation control (external)
- overcurrent limitation / overcurrent shutdown
- adjustable start ramp (external)
- adjustable current monitoring delay
- IxR compensation
- short circuit detection
- dynamic brake

To snap onto the DIN rail
EN 50022

Unit width: 22,5 mm

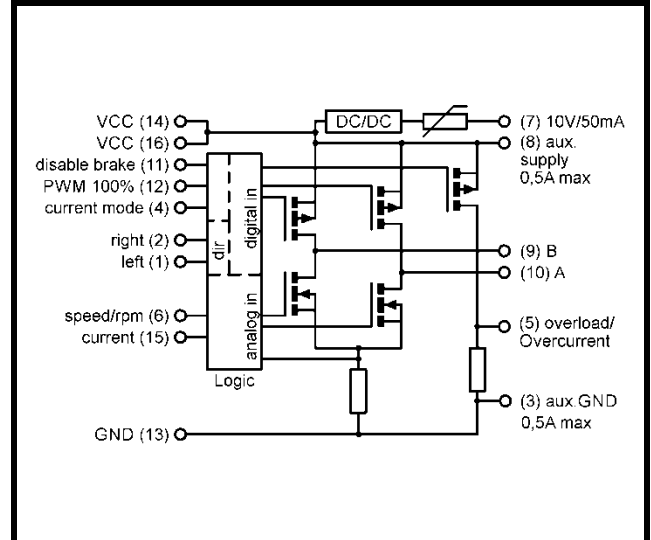

Type	MAE-4Q-5-30	
Article number	43046042	
Operating data		
Nominal voltage	U_{nom}	24,0 V DC
Supply voltage	V_{CC}	18 .. 30 V DC
Control inputs	U_{DI}	24,0 V DC
Analog input	U_{AI}	0 .. 10 V DC
Quiescent current typ	I_0	50 mA
Technical data: load circuit		
Max. current / continuous load current	I_{max}/I_{con}	15 / 5 A
Short circuit current detection typ	I_{SC}	80 A
Shut-down time after short circuit typ	t_{sc}	100 μ s
PWM frequency	F_S	15,6 kHz
Duty cycle trimmer TR4 (PWM)		5 .. 100 %
Power stage driver		MOS-FET
Other data		
Dimensions		22,5 x 70,4 x 85,0 mm
Connectors		push-in terminal, pitch 5 mm cross section 0,2 – 2,5 mm ²
Permissible ambient temperature	T_{amb}	-20 .. +50 °C
Temperature monitoring / overvoltage protection		yes / yes
Status indication: overcurrent / status		LED1 red / LED2 green

Other data	
Start ramp trimmer TR3 (start-ramp)	0 .. 4 s
Disable Time trimmer TR2 (CM-delay)	0 .. 1 s
Currentlimitation adjustable over DIP	0,5 .. 5 A
IxR compensation trimmer TR1 (IxR)	R _I 0 .. 2,1 Ω
Dynamic brake (Armature short circuit)	Can be switched off
Installation orientation / Assembly	any / top-hat rail EN 50022
Installation place, typical	Switch cabinet
Storage temperature	-30 .. +85 °C
Permissible humidity	0 .. 95 %, non-condensing
Weight	0,075 kg
Start up time	2 s
Hazardous substance norm	RoHS2
EMC interference immunity	EN 61326-1:2013-01 EN 61000-6-2:2005-08
EMC emitted interference, operation in industrial DC network	EN 61326-1:2013-01, Class A
EMC emitted interference, operation with power supply	EN 61326-1:2013-01, Class B

Technical data: digital input	
High Signal typ.	U > 10 V
Low Signal typ.	U < 4 V
Impedance typ.	R _{DI} 15 kΩ

Technical data: digital output overcurrent	
„Ready“	GND (4,7kΩ Pull-Down)
„Overcurrent“	VCC
Current typ	IDO 700 mA
Short circuit-proof	Yes, self-limiting

Technical data: analog input	
Voltage range	0 .. 10 V
V _{CC} tolerant	yes
Impedance typical	R _{AI} 98,5 kΩ

Flammability	
Housing, terminals, printed circuit board	UL94V-0

Starting behavior
 After applying supply voltage, the module MAE-4Q-5-30 is ready for operation when the start up time has elapsed.

Description
 The MAE-4Q-5-30 module is a multi-functional motor controller for use in industrial environments. It ensures the switching on and off, as well as the controlled driving of motors. The motor's direction of rotation can be set via a digital input. An internal trimmer can be used to set the maximum speed. By means of an analog input the speed can be set between 0 to maximum speed. The dynamic brake can be deactivated over a digital input. The module has an adjustable starting ramp and current monitoring delay. The IxR compensation can be used to minimize load-dependent speed changes. The maximum motor current can be set by DIP switches. Additionally the motor current can be reduced through an analog input during operation. A digital input allows to switch between the functions overcurrent shut-off and current limitation. By means of a further digital input, the module can be switched from the set speed to 100% speed.

Typical application: Standard

Typical application: PLC

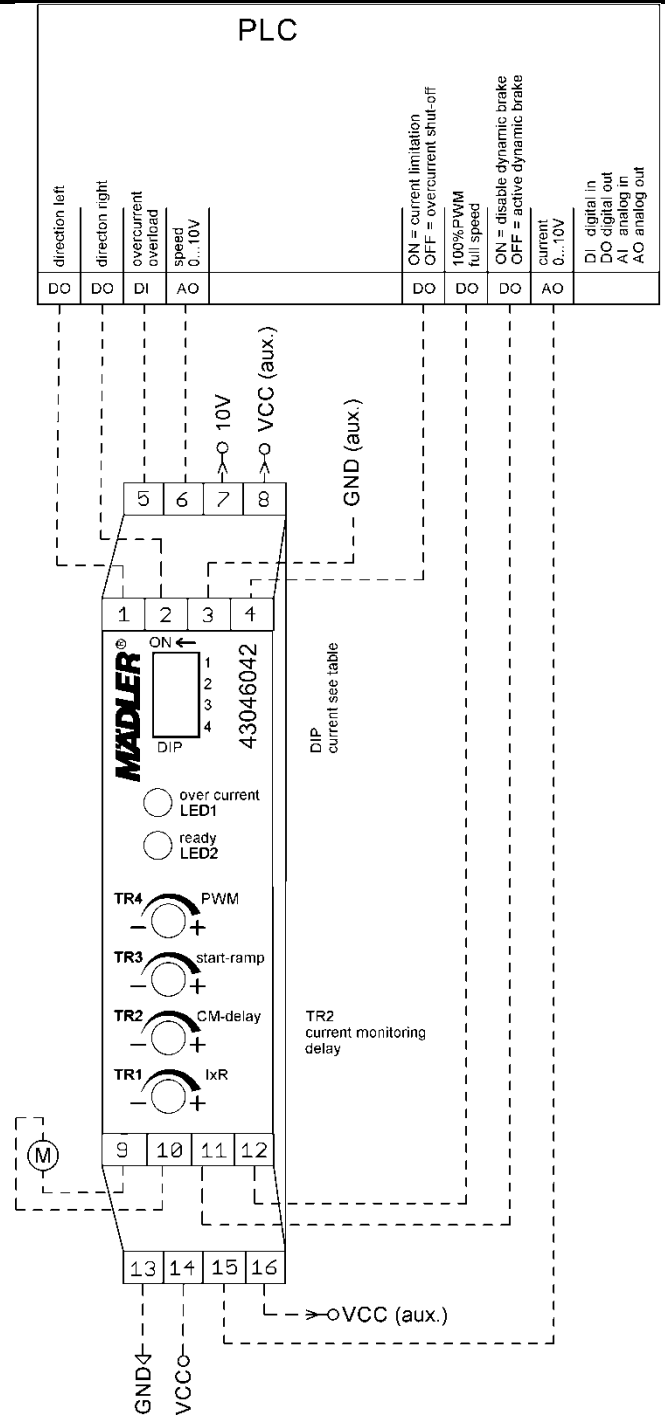
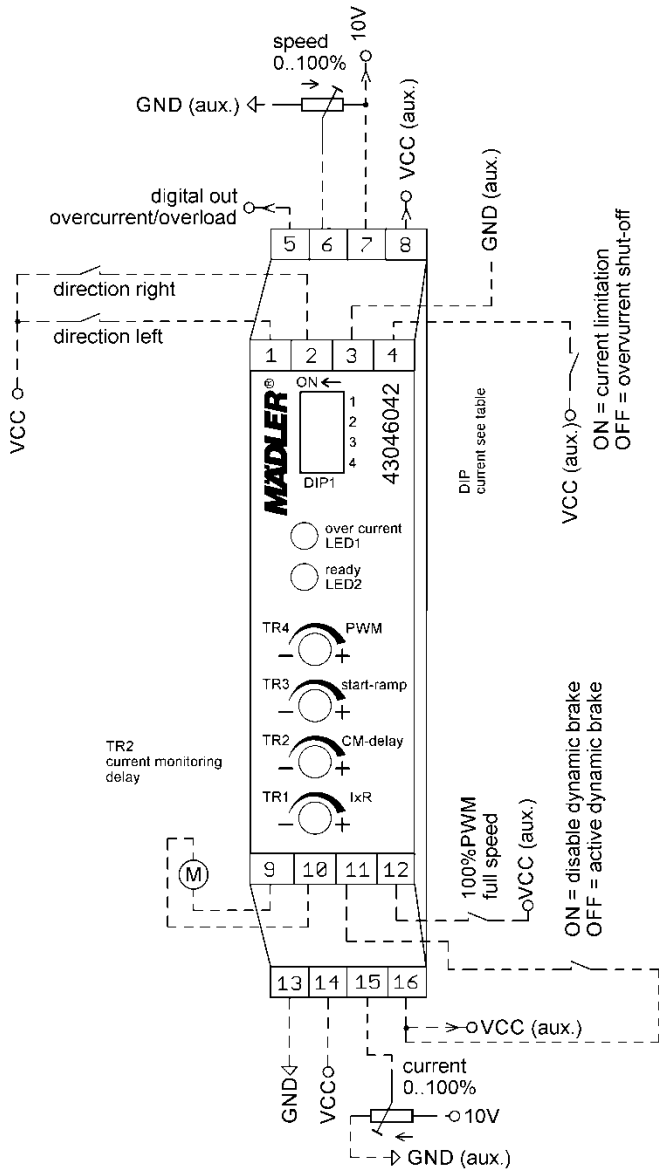

Terminal diagram

Terminal	5	6	7	8
Function	digital output „overcurrent“ High-active	analog input 0...10 V, „rotation speed“	Auxiliary voltage output +10 V/ approx. 50 mA (PTC-Fuse)	Auxiliary voltage output +24 V 0,5 A max
Terminal	1	2	3	4
Function	digital input „direction left“ (p- switch)	digital input „direction right“ (p- switch)	GND for external potentiometer 0,5 A max	digital input „current limitation/ overcurrent shutdown“ (p- switch)
Terminal	9	10	11	12
Function	Motor winding B	Motor winding A	digital input „disable dynamic brake“ (p- switch)	digital input „100 % PWM“ (p- switch)
Terminal	13	14	15	16
Function	GND supply	+24 V supply +/-10 %	analog input 0..10 V „current limit“	Auxiliary voltage output +24 V

State table

direction „left“ (1)	direction „right“ (2)	disable dyn. braking (11)	Motor „A“ (9)	Motor „B“ (10)	Funktion
0	1	X	VCC	□□□ GND	run right
1	0	X	□□□ GND	VCC	run left
1	1	X	GND	GND	dyn. braking
0	0	0	GND	GND	dyn. braking
0	0	1	open	open	off

0 = off 1 = on x = don't care

Function: Rotation speed control

The maximum output speed can be set or limited with the trimmer TR4.
 The speed setting itself is given through the analog input voltage at terminal (6) in the range of 0 to 100% adjustable via trimmer TR4.
 An analog voltage must be applied at terminal (6) in order to turn the motor. 0 V at terminal (6) equals to 0 rpm.
 If the module should operate only with the internal set speed, terminal (6) must be connected to + 10V / VCC, e.g. connect terminal (6) to terminal (7).

Function: PWM100%

If applying a HIGH signal at terminal (12), the motor output will be directly set to 100% PWM (speed). Regardless of any setting at TR4 or analog input at terminal (6).

- In case of a running motor. The ramp up function is not active. The current monitoring delay is started, so the current monitoring is not active for that time.
- If a HIGH signal at terminal (12) is set before setting the direction. The module ramps up with the adjusted ramp time on trimmer TR3 to 100% PWM (speed).

Function: dynamic brake

The module stops the motor with “dynamic brake” function by default. It can be deactivated by applying a HIGH signal at terminal (11).
 If dynamic braking is active, the motor winding is switched to GND at both terminals when switched off.
 The motor is stopped with armature short circuit braking.
 If dynamic braking is not active, the motor stops with no braking.
 If both rotation direction inputs (terminals 1 and 2) are simultaneously high, the motor always stops with a dynamic brake. In this case the brake setting at the digital input (11).

Function: short circuit detection

When the module detects a short circuit on the motor output, the motor switches off without dynamic braking. The motor can be restarted by means of a reset and fresh setting of any input of direction of rotation.

Function: overcurrent shut-off / current limitation

The module can be operated in overcurrent shut-off or current limitation mode. The mode is given by the digital input at terminal (4):
overcurrent shutdown:
 If the digital input is not active (not connected), the module is in the overcurrent shut-off mode. If the motor current exceeds the adjusted maximum motor current, the module turns off the motor. The motor can be restarted by resetting any of the two inputs of direction of rotation.
current limitation:
 When the digital input is applied with HIGH signal, the module is in current limitation mode. In this mode, the motor current is limited to the adjusted maximum value.

Function: setting the maximum motor current

The maximum motor current is adjusted via the DIP switch on the module and the analog input on terminal (15).
 The maximum permissible motor current is set via the DIP switches 1-4 (see table). The motor current itself is then given by the applied voltage at analog input on terminal (15), in the range from 0 to 100% of the preset value.
 If the module should be operated only with the maximum motor current setting of the DIP switches, the terminal 15 must be connected to +10V or to VCC, (e.g. bridge terminal (15) with terminal (16) or (7)).

DIP1	DIP2	DIP3	DIP4	Max. current [A]
Off	Off	Off	Off	0,5
On	Off	Off	Off	0,75
Off	On	Off	Off	1
On	On	Off	Off	1,25
Off	Off	On	Off	1,5
On	Off	On	Off	1,75
Off	On	On	Off	2
On	On	On	Off	2,25
Off	Off	Off	On	2,5
On	Off	Off	On	2,75
Off	On	Off	On	3
On	On	Off	On	3,25
Off	Off	On	On	3,5
On	Off	On	On	4
Off	On	On	On	4,5
On	On	On	On	5

Function: Start ramp

After setting any direction of rotation, the module ramps up the speed until the set value is reached. The gradient of the start ramp can be adjusted via trimmer TR3.

Function: IxR compensation

The module has a built in IxR compensation function. This function can be used to compensate load depending speed changes of the motor. The gain factor is set with trimmer TR1.
**!ATTENTION! Please use this function carefully!
 Incorrect gain factors may cause instable operation!**

Function: current monitoring delay

The current monitoring delay is adjustable by trimmer TR2. After setting any direction of rotation input the overcurrent shutdown is disabled for the adjusted time. The current monitoring delay is also started when setting the PWM100% digital input on terminal (12) to HIGH signal.

Function: Overcurrent output

The overcurrent output indicates by a HIGH signal:

In current limitation mode:

As long as the motor current is limited.

In overcurrent shut-off mode

As soon as over current is detected and motor is stopped.

Device status

The module status is displayed via the LEDs on the module front plate.

LED1 red	LED2 green	meaning
Off	On	Module is operational
On	flashing	overcurrent shut-off active and overcurrent detected
On	On	Current limitation active and overcurrent detected
On/Off	flashing	Module error 1 (see table)
flashing	flashing	Internal Error

Display elements

Module errors are displayed as flashing sequences. The end of the sequence is indicated by a pause of 1 second.

The number of flashes indicates the error number.

Module error 1

1	overcurrent
2	Over-temperature
3	short circuit detected
4	overvoltage
5	overload
6	Under-temperature
7	Low supply voltage
8	

Dimensional drawing

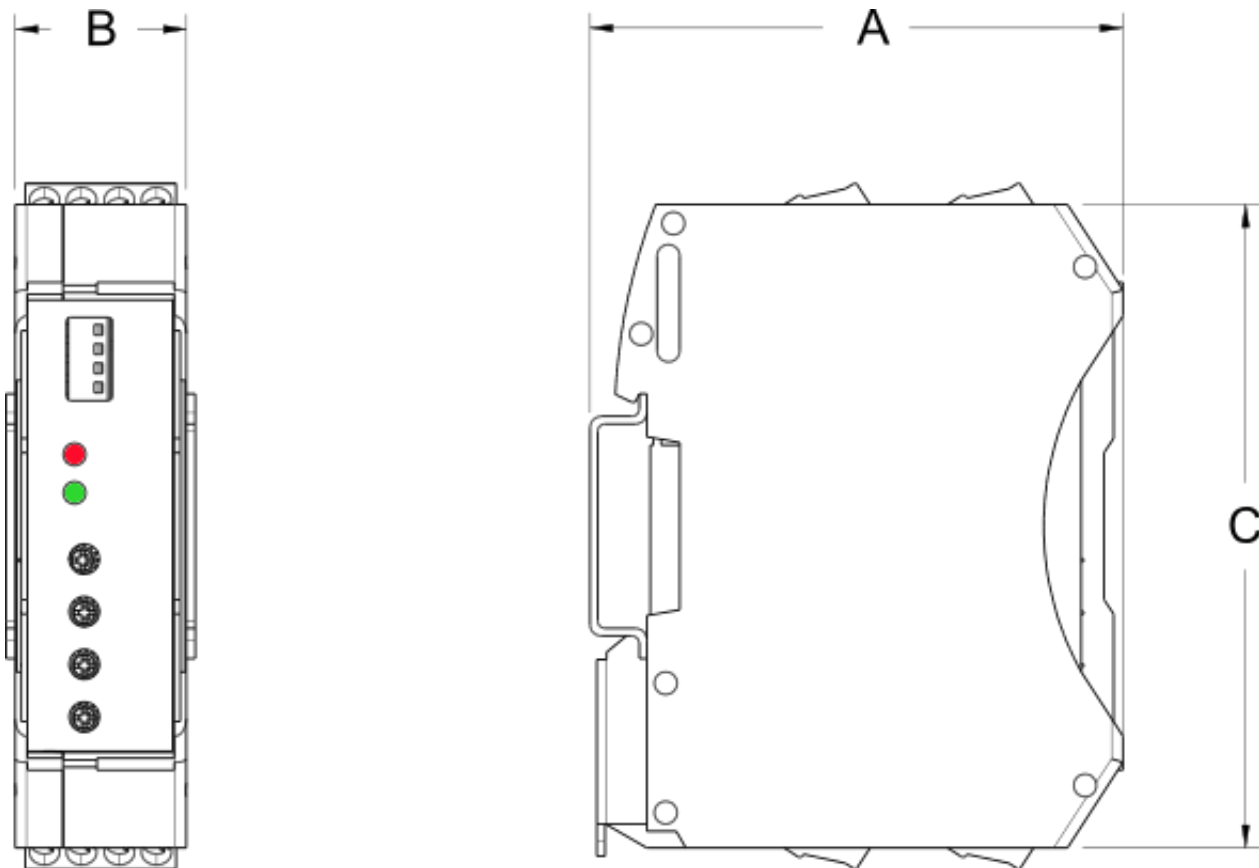

A = 70,4 mm; B = 22,5 mm; C = 85 mm

Safety notes

Maximum operational data

The maximum operating data must not be exceeded.

Installation

The installation and start-up must be performed by specialist personnel exclusively.

All affected components must be disconnected from the mains.

Start-up

For the first start-up, the motor should be operated without load.

Risk of death

Do not touch live parts after switching on!

The assembly must be operated exclusively on safety extra-low voltage. With operation on extra-low voltage (e.g. via autotransformer), death or injury can occur.

Fire protection

The assembly must be installed in a switch cabinet, which is suitable as a fire protection enclosure.

The assembly must be safeguarded with a pre-fuse aligned with the nominal data.

Field of application

The assembly may only be used as intended.

Other components must be checked for their approvals and regulations.

Safety devices

An additional safety device must be used to bring the system into a safe state in case of a cable break, incorrect operation, failure of the control/controller unit.

EMC / EMI

The wiring must be done according to EMC / EMI standards. If necessary, shielded cables and EMC suppressors must be used for the connected consumer.

For operation in a public low-voltage distribution network, the module must be supplied with an approved AC adapter.

If the module is supplied with an AC adapter, other equipment, operated on the same power supply, must be suitable for use in industrial environments.

Repairs

Repairs must be performed by authorised persons exclusively. With unauthorised opening, the warranty cover is voided and this may also result in danger for the user and for the system.

Maintenance

The assembly is wear-free by design.

For modules **with** cooling openings free air circulation must be checked at the cooling openings or on the housing at regular intervals. If necessary, the cooling holes / the housing must be cleaned.

Good ventilation must be ensured.