

Double-Sprockets ZRET for two Single-Strand Roller Chains DIN ISO 606 (formerly DIN 8187), for Taper Bushes

Material: Steel C45, not hardened.

Teeth milled.

Double-Sprockets for transmitting the power from a driving chain to a parallel running driven chain, e.g. at roller conveyors.

Version for taper bushes, for easy and fast mounting.

The taper bush has to be ordered separately, see page 340.

Ordering Details: e.g.: Product No. 121 774 18, Double Sprocket 2x 06 B-1, 18 Teeth, for Taper Bush 1008

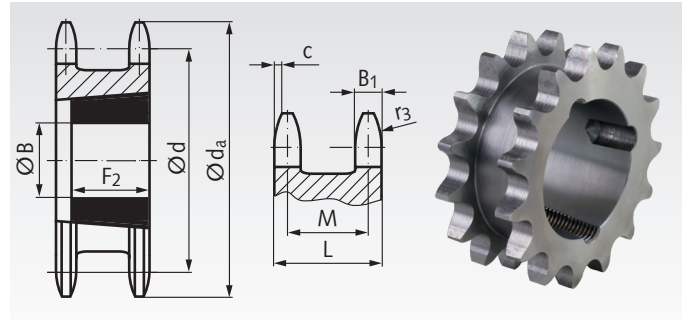

2 x ISO 06 B-1, Pitch 3/8 x 7/32"

$B_1 = \text{max. } 5.3 \text{ mm}$, $c = 1.0 \text{ mm}$, $r_3 = 10 \text{ mm}$

Product No.	Number of teeth	d_a mm	d mm	B_{max} mm	F_2 mm	L mm	M mm	Weight kg	Taper bush type
121 774 18	18	58,3	54,85	25	22,2	23,5	18,2	0,19	1008
121 774 19	19	61,3	57,87	25	22,2	23,5	18,2	0,23	1008
121 774 20	20	64,3	60,89	28	22,2	23,5	18,2	0,25	1108
121 774 21	21	68,0	63,91	28	22,2	23,5	18,2	0,31	1108
121 774 23	23	73,5	69,95	28	22,2	23,5	18,2	0,41	1108
121 774 25	25	80,0	76,00	28	22,2	23,5	18,2	0,53	1108

2 x ISO 08 B-1, Pitch 1/2 x 5/16"

$B_1 = \text{max. } 7.2 \text{ mm}$, $c = 1.3 \text{ mm}$, $r_3 = 13 \text{ mm}$

Product No.	Number of teeth	d_a mm	d mm	B_{max} mm	F_2 mm	L mm	M mm	Weight kg	Taper bush type
125 774 15	15	65,5	61,09	25	22,2	31	23,8	0,36	1008
125 774 16	16	69,5	65,10	28	22,2	31	23,8	0,43	1108
125 774 17	17	73,6	69,11	28	22,2	31	23,8	0,39	1108
125 774 18	18	77,8	73,14	32	25,4	31	23,8	0,48	1210
125 774 19	19	81,7	77,16	32	25,4	31	23,8	0,58	1210
125 774 20	20	85,8	81,19	32	25,4	31	23,8	0,65	1210
125 774 21	21	89,7	85,22	42	25,4	31	23,8	0,63	1610
125 774 23	23	98,2	93,27	42	25,4	31	23,8	0,87	1610
125 774 25	25	105,8	101,33	50	31,8	31	23,8	0,87	2012

2 x ISO 10 B-1, Pitch 5/8 x 3/8"

$B_1 = \text{max. } 9.1 \text{ mm}$, $c = 1.6 \text{ mm}$, $r_3 = 16 \text{ mm}$

Product No.	Number of teeth	d_a mm	d mm	B_{max} mm	F_2 mm	L mm	M mm	Weight kg	Taper bush type
126 774 12	12	68,0	61,34	28	22,2	36,5	27,4	0,42	1108
126 774 13	13	73,0	66,32	28	22,2	36,5	27,4	0,53	1108
126 774 14	14	78,0	71,34	28	22,2	36,5	27,4	0,67	1108
126 774 15	15	83,0	76,36	32	25,4	36,5	27,4	0,64	1210
126 774 16	16	88,0	81,37	32	25,4	36,5	27,4	0,81	1210
126 774 17	17	93,0	86,39	42	25,4	36,5	27,4	0,80	1610
126 774 18	18	98,3	91,42	42	25,4	36,5	27,4	0,98	1610
126 774 19	19	103,3	96,45	42	25,4	36,5	27,4	1,17	1610
126 774 20	20	108,4	101,49	42	25,4	36,5	27,4	1,36	1610
126 774 21	21	113,4	106,52	50	31,8	36,5	27,4	1,24	2012
126 774 23	23	123,4	116,58	50	31,8	36,5	27,4	1,69	2012
126 774 25	25	134,0	126,66	50	31,8	36,5	27,4	2,20	2012

2 x ISO 12 B-1, Pitch 3/4 x 7/16"

$B_1 = \text{max. } 11.1 \text{ mm}$, $c = 2.0 \text{ mm}$, $r_3 = 19 \text{ mm}$

Product No.	Number of teeth	d_a mm	d mm	B_{max} mm	F_2 mm	L mm	M mm	Weight kg	Taper bush type
127 774 13	13	87,5	79,59	32	25,4	45	33,9	0,94	1210
127 774 14	14	93,6	85,61	32	25,4	45	33,9	1,16	1210
127 774 15	15	99,8	91,63	42	25,4	45	33,9	1,18	1610
127 774 16	16	105,5	97,65	42	25,4	45	33,9	1,49	1610
127 774 17	17	111,5	103,67	42	25,4	45	33,9	1,73	1610
127 774 18	18	118,0	109,71	50	31,8	45	33,9	1,62	2012
127 774 19	19	124,2	115,75	50	31,8	45	33,9	1,95	2012
127 774 20	20	129,7	121,78	65	44,5	45	33,9	1,70	2517
127 774 21	21	136,0	127,82	65	44,5	45	33,9	2,05	2517
127 774 23	23	149,0	139,90	65	44,5	45	33,9	2,85	2517
127 774 25	25	160,0	152,00	65	44,5	45	33,9	3,75	2517

2 x ISO 16 B-1, Pitch 1" x 17.02 mm

$B_1 = \text{max. } 16.2 \text{ mm}$, $c = 2.5 \text{ mm}$, $r_3 = 26 \text{ mm}$

Product No.	Number of teeth	d_a mm	d mm	B_{max} mm	F_2 mm	L mm	M mm	Weight kg	Taper bush type
128 774 12	12	109,0	98,14	42	38,1	63,5	47,3	1,90	1615
128 774 13	13	117,0	106,12	42	38,1	63,5	47,3	2,50	1615
128 774 14	14	125,0	114,15	50	31,8	63,5	47,3	2,50	2012
128 774 15	15	133,0	122,17	50	31,8	63,5	47,3	3,10	2012
128 774 16	16	141,0	130,20	50	31,8	63,5	47,3	3,75	2012
128 774 17	17	149,0	138,22	65	44,5	63,5	47,3	3,90	2517
128 774 18	18	157,0	146,28	65	44,5	63,5	47,3	4,70	2517
128 774 19	19	165,2	154,33	65	44,5	63,5	47,3	5,50	2517
128 774 20	20	173,2	162,38	75	50,8	63,5	47,3	5,15	3020
128 774 21	21	181,2	170,43	75	50,8	63,5	47,3	6,05	3020
128 774 23	23	197,5	186,53	90	63,5	63,5	47,3	7,20	3525
128 774 25	25	213,5	202,66	90	63,5	63,5	47,3	9,40	3525

Taper bushes page 340

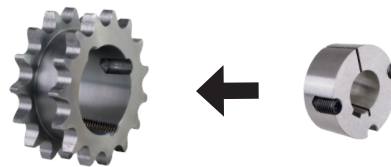

Description and mounting instructions page 867

