

Sprockets with One-Sided Hub, ISO 08 B-1

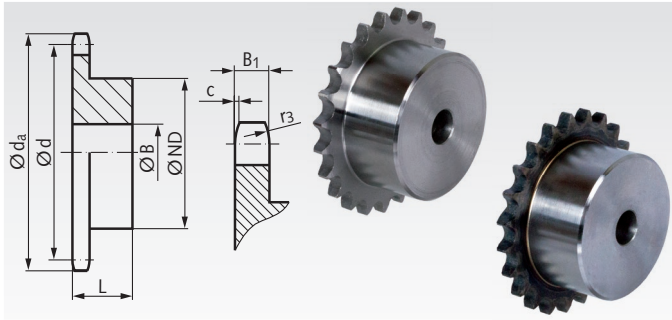

Material: Steel C45, optionally hardened.
Pre-bored. Sprockets marked with * from grey cast iron GG25.

Type KRS: Not hardened.

Type KRG: Teeth induction hardened (approx. HRC 50).

Ordering Details: e.g.: Product No. 105 108 00, KRS, ISO 08 B-1, 8 Teeth

ISO 08 B-1, Pitch 1/2 x 5/16" KRS and KRG

$B_1 = 7.2$ mm, $c = 1.3$ mm, $r_3 = 13$ mm

Product No. Type KRS	Product No. Type KRG	Number of teeth	d_a mm	d mm	ND mm	B mm	L mm	Weight g
105 108 00	105 881 08	8	37,2	33,18	20	10	25	66
105 109 00	105 881 09	9	41,0	37,13	24	10	25	96
105 110 00	105 881 10	10	45,2	41,10	26	10	25	120
105 111 00	105 881 11	11	48,7	45,07	29	10	25	148
105 112 00	105 881 12	12	53,0	49,07	33	10	28	212
105 113 00	105 881 13	13	57,4	53,07	37	10	28	264
105 114 00	105 881 14	14	61,8	57,07	41	10	28	323
105 115 00	105 881 15	15	65,5	61,09	45	10	28	385
105 116 00	105 881 16	16	69,5	65,10	50	12	28	461
105 117 00	105 881 17	17	73,6	69,11	52	12	28	502
105 118 00	105 881 18	18	77,8	73,14	56	12	28	588
105 119 00	105 881 19	19	81,7	77,16	60	12	28	670
105 120 00	105 881 20	20	85,8	81,19	64	12	28	758
105 121 00	105 881 21	21	89,7	85,22	68	14	28	855
105 122 00	105 881 22	22	93,8	89,24	70	14	28	917
105 123 00	105 881 23	23	98,2	93,27	70	14	28	948
105 124 00	105 881 24	24	101,8	97,29	70	14	28	972
105 125 00	105 881 25	25	105,8	101,33	70	14	28	1002
105 126 00	105 881 26	26	110,0	105,36	70	16	30	1096
105 127 00	105 881 27	27	114,0	109,40	70	16	30	1140
105 128 00	105 881 28	28	118,0	113,42	70	16	30	1167
105 129 00	105 881 29	29	122,0	117,46	80	16	30	1411
105 130 00	105 881 30	30	126,1	121,50	80	16	30	1446
105 132 00	105 881 32	32	134,3	129,56	90	16	30	1786
105 134 00	105 881 34	34	142,6	137,64	90	16	30	1867
105 135 00	105 881 35	35	146,7	141,68	90	16	30	1921
105 136 00	105 881 36	36	151,0	145,72	90	16	35	2208
105 138 00	105 881 38	38	158,6	153,80	90	16	35	2317
105 140 00	105 881 40	40	166,8	161,87	90	16	35	2444
105 145 00*	-	45	188,0	182,07	70	24	40	1977
105 157 00*	-	57	236,4	230,54	70	24	40	2381
105 176 00*	-	76	313,3	307,33	80	24	40	4333
105 183 00*	-	95	390,1	384,11	80	24	45	4871
105 188 00*	-	114	466,9	460,90	80	24	45	7049



Sprockets marked with * are made from grey cast iron GG25.

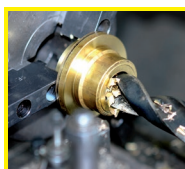

**Reworking within
24h-service possible.
Custom made parts
on request.**

Plate wheels KRL, ISO 08 B-1

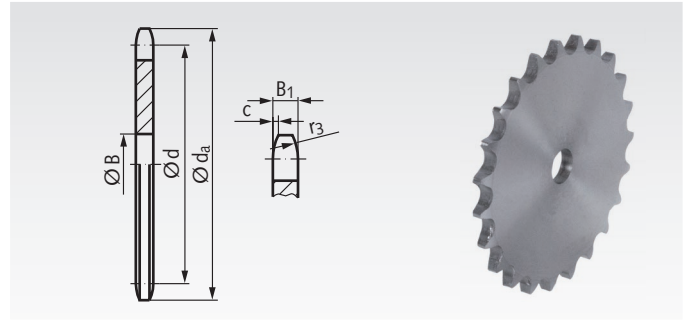

Material: Low-carbon steel, not hardable.
Pre-bored.

Type KRL: Without hub, not hardened.

Ordering Details: e.g.: Product No. 105 208 00, KRL, ISO 08 B-1, 8 Teeth

ISO 08 B-1, Pitch 1/2 x 5/16" KRL

$B_1 = 7.2$ mm, $c = 1.3$ mm, $r_3 = 13$ mm

Product No. Type KRL	Number of teeth	d_a mm	d mm	B mm	Weight g
105 208 00	8	37,2	33,18	8	33
105 209 00	9	41,0	37,13	8	42
105 210 00	10	45,2	41,10	8	54
105 211 00	11	48,7	45,07	10	67
105 212 00	12	53,0	49,07	10	81
105 213 00	13	57,4	53,07	10	96
105 214 00	14	61,8	57,07	10	107
105 215 00	15	65,5	61,09	10	135
105 216 00	16	69,5	65,10	10	153
105 217 00	17	73,6	69,11	10	177
105 218 00	18	77,8	73,14	10	200
105 219 00	19	81,7	77,16	10	230
105 220 00	20	85,8	81,19	10	255
105 221 00	21	89,7	85,22	12	279
105 222 00	22	93,8	89,24	12	312
105 223 00	23	98,2	93,27	12	338
105 224 00	24	101,8	97,29	12	363
105 225 00	25	105,8	101,33	12	392
105 226 00	26	110,0	105,36	16	432
105 227 00	27	114,0	109,40	16	456
105 228 00	28	118,0	113,42	16	500
105 229 00	29	122,0	117,46	16	537
105 230 00	30	126,1	121,50	16	573
105 232 00	32	134,3	129,56	16	664
105 234 00	34	142,6	137,64	16	744
105 235 00	35	146,7	141,68	16	782
105 236 00	36	151,0	145,72	16	828
105 238 00	38	158,6	153,80	16	933
105 240 00	40	166,8	161,87	16	1060
105 242 00	42	175,4	169,95	20	1151
105 244 00	44	183,8	178,03	20	1283
105 245 00	45	188,0	182,07	20	1363
105 246 00	46	192,1	186,10	20	1493
105 248 00	48	200,3	194,18	20	1523
105 250 00	50	208,3	202,26	20	1639
105 254 00	54	224,1	218,43	20	1925
105 257 00	57	236,4	230,54	20	2149
105 260 00	60	248,6	242,66	20	2492
105 265 00	65	269,0	262,86	25	2834
105 270 00	70	289,0	283,07	25	3250
105 272 00	72	297,2	291,16	25	3482
105 276 00	76	313,3	307,33	25	3887
105 280 00	80	329,4	323,48	25	4327
105 283 00	95	390,1	384,11	25	6150
105 288 00	114	466,9	460,90	25	9028
105 290 00	120	491,2	485,16	25	10005

Sprockets made from stainless steel page 64.
Sprockets ready-to-mount page 68.
Sprockets for Taper clamping bushes page 82.