

## Sprockets KRT / KRTG with One-Sided Hub, for Taper Bushes

Material: Steel C45, optionally hardened or grey cast iron.

Type KRT: Not hardened.

Type KRTG: Teeth induction hardened (approx. HRC 50).

Sprockets for taper bushes, for easy and fast mounting.  
The taper bush has to be ordered separately, see page 340.

Product numbers ending with G are made from grey cast iron GG25. At sprockets marked with \*, the teeth are centered on the wheel body, see drawing.

Ordering Details: e.g.: Product No. 101 771 17, KRT, ISO 06 B-1, 17 Teeth,  
Dimension bore with Reference to Taper Bush Type, see page 340.

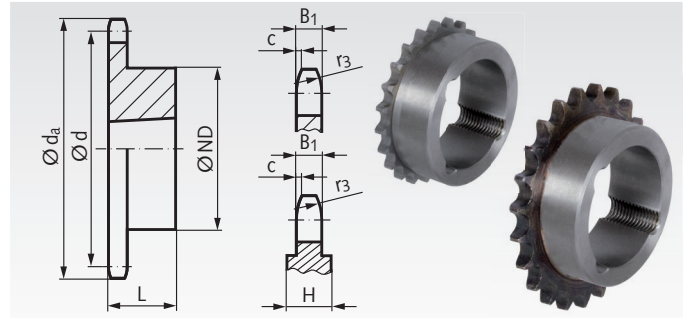

### ISO 06 B-1, Pitch 3/8 x 7/32"

$B_1 = 5.3$  mm,  $c = 1.0$  mm,  $r_3 = 10$  mm

Product No. KRT	Product No. KRTG	Number of teeth	$d_a$ mm	$d$ mm	ND mm	L mm	Weight kg	Taper-bush
101 771 17	101 781 17	17	55,3	51,83	45	22	0,11	1008
101 771 18	101 781 18	18	58,3	54,85	45	22	0,14	1008
101 771 19	101 781 19	19	61,3	57,87	45	22	0,15	1008
101 771 20	101 781 20	20	64,3	60,89	46	22	0,16	1008
101 771 21	101 781 21	21	68,0	63,91	46	22	0,18	1008
101 771 22	101 781 22	22	71,0	66,93	50	22	0,25	1108
101 771 23	101 781 23	23	73,5	69,95	63	25	0,27	1210
101 771 24	101 781 24	24	77,0	72,97	63	25	0,30	1210
101 771 25	101 781 25	25	80,0	76,00	63	25	0,32	1210
101 771 26	101 781 26	26	83,0	79,02	63	25	0,33	1210
101 771 27	101 781 27	27	86,0	82,05	63	25	0,34	1210
101 771 28	101 781 28	28	89,0	85,07	63	25	0,37	1210
101 771 30	101 781 30	30	94,7	91,12	63	25	0,39	1210
101 771 38	-	38	119,5	115,35	70	25	0,65	1210
101 771 45	-	45	140,7	136,55	70	25	1,01	1210
101 771 57	-	57	176,9	172,91	70	25	1,20	1210
101 771 57G	-	57	176,9	172,91	83	25	1,44	1210
101 771 76G	-	76	234,9	230,47	83	25	1,84	1210
101 771 83	-	95	292,5	288,08	80	25	3,00	1210
101 771 83G	-	95	292,5	288,08	83	25	2,52	1210
101 771 88G	-	114	349,6	345,68	83	38	5,00	1215

### ISO 08 B-1, Pitch 1/2 x 5/16"

$B_1 = 7.2$  mm,  $c = 1.3$  mm,  $r_3 = 13$  mm

Product No. KRT	Product No. KRTG	Number of teeth	$d_a$ mm	$d$ mm	ND mm	L mm	Weight kg	Taper-bush
105 771 14	-	14	61,8	57,07	45	22	0,15	1008
105 771 15	105 781 15	15	65,0	61,09	45	22	0,19	1008
105 771 16	105 781 16	16	69,5	65,10	50	22	0,24	1108
105 771 17	105 781 17	17	73,6	69,11	60	25	0,24	1210
105 771 18	105 781 18	18	77,8	73,14	60	25	0,29	1210
105 771 19	105 781 19	19	81,7	77,16	63	25	0,34	1210
105 771 20	105 781 20	20	85,8	81,19	71	25	0,34	1610
105 771 21	105 781 21	21	89,7	85,22	71	25	0,38	1610
105 771 22	105 781 22	22	93,8	89,24	71	25	0,43	1610
105 771 23	105 781 23	23	98,2	93,27	76	25	0,48	1610
105 771 24	105 781 24	24	101,8	97,29	76	25	0,67	1610
105 771 25	105 781 25	25	105,8	101,33	76	25	0,72	1610
105 771 26	105 781 26	26	110,0	105,36	76	25	0,82	1610
105 771 27	105 781 27	27	114,0	109,40	76	25	0,86	1610
105 771 28	105 781 28	28	118,0	113,42	90	32	0,86	2012
105 771 30	105 781 30	30	126,1	121,50	90	32	0,91	2012
105 771 38	-	38	158,6	153,80	90	32	1,20	2012
105 771 45	-	45	188,0	182,07	100	32	1,68	2012
105 771 57	-	57	236,4	230,54	100	32	2,70	2012
105 771 57G	-	57	236,4	230,54	111	32	2,78	2012
105 771 76	-	76	313,3	307,33	100	32	4,70	2012
105 771 76G	-	76	313,3	307,33	111	32	3,81	2012
105 771 83G	-	95	390,1	384,11	111	32	6,40	2012
105 771 88G *	-	114	466,9	460,90	124	45	8,50	2517

\* H=15,2mm.

### ISO 10 B-1, Pitch 5/8 x 3/8"

$B_1 = 9.1$  mm,  $c = 1.6$  mm,  $r_3 = 16$  mm

Product No. KRT	Product No. KRTG	Number of teeth	$d_a$ mm	$d$ mm	ND mm	L mm	Weight kg	Taper-bush
106 771 13	106 781 13	13	73,0	66,32	47	22	0,24	1008
106 771 14	106 781 14	14	78,0	71,34	52	22	0,29	1108
106 771 15	106 781 15	15	83,0	76,36	60	25	0,34	1210
106 771 16	106 781 16	16	88,0	81,37	70	25	0,34	1610
106 771 17	106 781 17	17	93,0	86,39	71	25	0,38	1610
106 771 18	106 781 18	18	98,3	91,42	75	25	0,43	1610
106 771 19	106 781 19	19	103,3	96,45	75	25	0,62	1610
106 771 20	106 781 20	20	108,4	101,49	75	25	0,77	1610
106 771 21	106 781 21	21	113,4	106,52	76	25	0,72	1610
106 771 22	106 781 22	22	118,0	111,55	76	25	0,77	1610
106 771 23	106 781 23	23	123,4	116,58	76	25	0,96	1610
106 771 24	106 781 24	24	128,3	121,62	90	32	1,06	2012
106 771 25	106 781 25	25	134,0	126,66	90	32	1,15	2012
106 771 26	106 781 26	26	139,0	131,70	90	32	1,20	2012
106 771 27	106 781 27	27	144,0	136,75	90	32	1,25	2012
106 771 28	106 781 28	28	148,7	141,78	90	32	1,34	2012
106 771 30	106 781 30	30	158,8	151,87	90	32	1,54	2012
106 771 38	-	38	199,2	192,24	100	32	2,40	2012
106 771 45	-	45	235,0	227,58	100	32	3,12	2012
106 771 57	-	57	296,0	288,18	100	32	5,00	2012
106 771 57G	-	57	296,0	288,18	111	32	4,28	2012
106 771 76G	-	76	392,1	384,16	111	32	8,0	2012
106 771 83G *	-	95	488,5	480,14	124	45	9,0	2517
106 771 88G *	-	114	584,1	576,13	124	45	15,5	2517

\* H=18,9mm.

### ISO 12 B-1, Pitch 3/4 x 7/16"

$B_1 = 11.1$  mm,  $c = 2.0$  mm,  $r_3 = 19$  mm

Product No. KRT	Product No. KRTG	Number of teeth	$d_a$ mm	$d$ mm	ND mm	L mm	Weight kg	Taper-bush
107 771 13	107 781 13	13	87,5	79,59	60	25	0,38	1210
107 771 14	107 781 14	14	93,6	85,61	70	25	0,48	1610
107 771 15	107 781 15	15	99,8	91,63	70	25	0,48	1610
107 771 16	107 781 16	16	105,5	97,65	75	25	0,67	1610
107 771 17	107 781 17	17	111,5	103,67	76	25	0,86	1610
107 771 18	107 781 18	18	118,0	109,71	90	32	0,91	2012
107 771 19	107 781 19	19	124,2	115,75	90	32	1,06	2012
107 771 20	107 781 20	20	129,7	121,78	90	32	1,06	2012
107 771 21	107 781 21	21	136,0	127,82	102	45	1,20	2517
107 771 22	107 781 22	22	141,8	133,86	102	45	1,34	2517
107 771 23	107 781 23	23	149,0	139,90	108	45	1,49	2517
107 771 24	107 781 24	24	153,9	145,94	108	45	1,63	2517
107 771 25	107 781 25	25	160,0	152,00	108	45	1,78	2517
107 771 26	107 781 26	26	165,9	158,04	108	45	1,92	2517
107 771 27	107 781 27	27	172,3	164,09	108	45	2,02	2517
107 771 28	107 781 28	28	178,0	170,13	108	45	2,21	2517
107 771 30	107 781 30	30	190,5	182,24	108	45	2,49	2517
107 771 38	-	38	239,0	230,69	108	45	3,74	2517
107 771 45	-	45	282,5	273,10	108	45	5,52	2517
107 771 45G *	-	45	282,5	273,10	118	45	4,60	2517
107 771 57	-	57	354,0	345,81	108	45	8,46	2517
107 771 57G *	-	57	354,0	345,81	124	45	9,12	2517
107 771 76G *	-	76	469,9	460,99	124	45	12,00	2517
107 771 83G *	-	95	585,1	576,17	124	45	17,00	2517
107 771 88G *	-	114	700,6	691,36	124	64	23,00	2525

\* 45 teeth and 57 teeth: H=18.9mm.

76 to 114 teeth: H=23.6mm.