

Small Geared Motors CRO, 230V

Motor: For 230V, 50Hz synchronous motor for both rotational directions (see motor data overview).

Gearbox: Spur gears, straight toothed, made from plastic.

Ambient temperature: -5 to +70°C

Capacitor: Included in delivery.

Version A: one-stage, up to 50 Ncm.

Version B: two-stage, up to 200 Ncm.

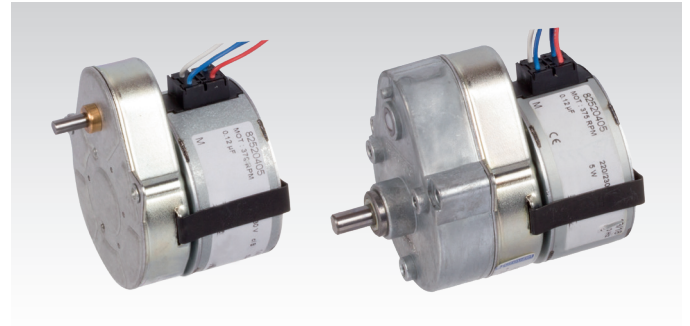

Version A

Version B

Ordering details: e.g.: Type, Version, Output Speed, Product No.

Version A

Product No.	Standard Speed min ⁻¹	Weight kg
430 200 00	60	0,25
430 200 01	30	0,25
430 200 02	15	0,25
430 200 03	10	0,25
430 200 06	5	0,25
430 200 08	3,12	0,25
430 200 09	2	0,25
430 200 10	1	0,25

Torque-Speed Table

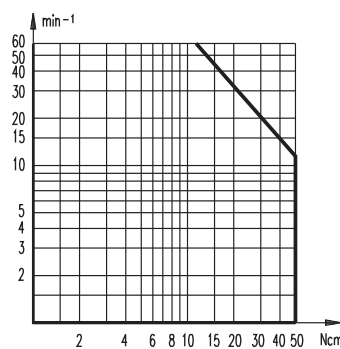

Max. perm. static load on bearing:
axial = 10 N, radial = 80 N

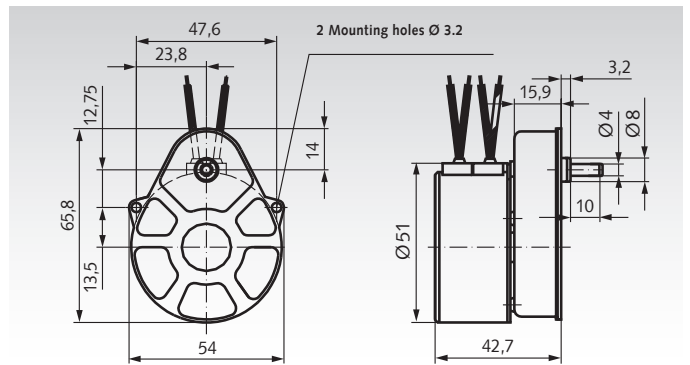

Version B

Product No.	Standard Speed min ⁻¹	Weight kg
430 205 00	15	0,32
430 205 01	7,5	0,32
430 205 02	5	0,32
430 205 13	1,13	0,32
430 205 04	0,25	0,32

Torque-Speed Table

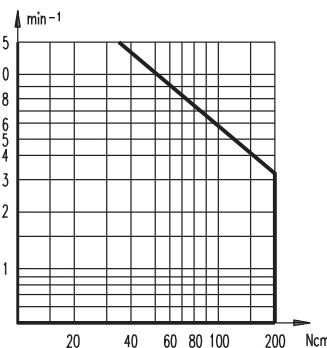

Max. perm. static load on bearing:
axial = 10 N, radial = 100 N

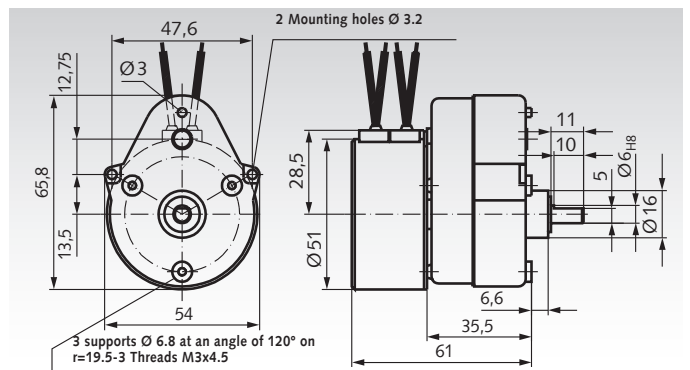

Motor data/Technical data

Moment of inertia for rotor	18.8 g·cm ²
Absorbed power	3.5 W
Stall torque ¹⁾	2.1 Ncm
Starting torque	1.9 Ncm
Max. coil temperature	120 °C
Ambient temperature	-5 +70 °C
Storage temperature	-40 +100 °C
Insulation resistance	>10 ³ MV
Electric strength (50 Hz)	> 2400 V
Weight of motor	210 g
Protection class	IP 40
Standard nominal voltage (-15 + 10%)	220/240 V
Absorbed power	16/17.3 mA
Frequency	50 Hz
Speed	375 min ⁻¹
Capacitor values ±10%	0.12/600 µf/V
Connection	A

Wiring (parallel line connection)

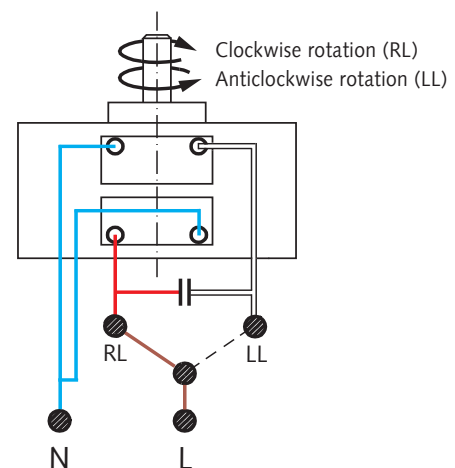

N = Neutral
L = Phase

¹⁾ Max. torque of the motor at continuous operation with nominal voltage and frequency.