

Articulated Levelling Feet 344 and 344.5 Plastic with Steel or Stainless Steel Bolt

Material Version 344: base: plastic (polyamide), glass-fibre reinforced, matt finish black.

Bolt: steel, strength class 5.8., zinc-plated, chromated.

Rubber pad: NBR, hardness 70° Shore A, black.

Type A: without nut, without rubber pad, bolt steel.

Type AG: without nut, with rubber pad, bolt steel.

Material Version 344.5: Base: Plastic (polyamide), glass-fibre

reinforced, matt finish black. Bolt M10, M12,

M16 (SW16): 1.4305 (AISI 303). Bolt M20, M24: 1.4301 **STAINLESS** (AISI 304).

Rubber pad: NBR (perbunan) 70° Shore hardness, black.

Type N: without nut, without rubber pad, bolt stainless steel.

Type NG: without nut, with rubber pad, bolt stainless steel.

Ordering Details: e.g.: Product No. 655 301 00 Foot 344, A, Ø 60 x 43 mm

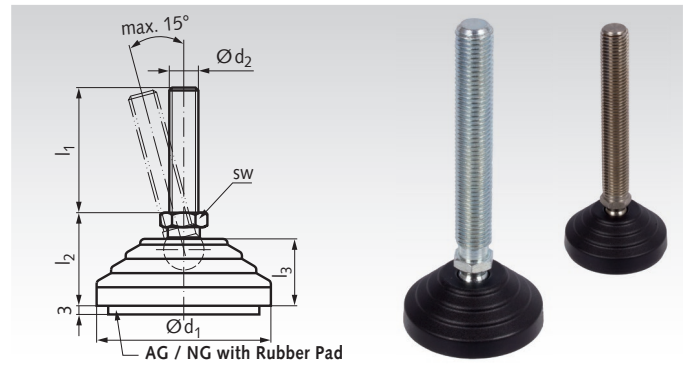

Version 344, steel		Version 344.5, stainless		d ₁ mm	d ₂ mm	l ₁ mm	l ₂ mm	l ₃ mm	sw mm	Ball Ø mm	Static Load N*	Weight kg
Product No. Type A	Product No. Type AG	Product No. Type N	Product No. Type NG									
655 301 00	655 331 00	655 993 01	655 993 31	60	M10	43	32	23	14	14	14000	0,05
655 302 00	655 332 00	655 993 02	655 993 32	60	M10	68	32	23	14	14	14000	0,08
655 303 00	655 333 00	655 993 03	655 993 33	60	M10	98	32	23	14	14	14000	0,16
655 304 00	655 334 00	655 993 04	655 993 34	60	M12	43	32	23	14	14	14000	0,07
655 305 00	655 335 00	655 993 05	655 993 35	60	M12	68	32	23	14	14	14000	0,10
655 306 00	655 336 00	655 993 06	655 993 36	60	M12	98	32	23	14	14	14000	0,19
655 311 00	655 341 00	655 993 11	655 993 41	60	M16	68	32	23	16	14	14000	0,14
655 312 00	655 342 00	655 993 12	655 993 42	60	M16	108	32	23	16	14	14000	0,12
655 313 00	655 343 00	655 993 13	655 993 43	60	M16	148	32	23	16	14	14000	0,27
655 314 00	655 344 00	655 993 14	655 993 44	80	M16	68	32	23	16	14	16000	0,16
655 315 00	655 345 00	655 993 15	655 993 45	80	M16	108	32	23	16	14	16000	0,21
655 316 00	655 346 00	655 993 16	655 993 46	80	M16	148	32	23	16	14	16000	0,26
655 321 00	655 351 00	655 993 21	655 993 51	80	M20	98	42	23	24	24	18000	0,36
655 322 00	655 352 00	655 993 22	655 993 52	80	M20	138	42	23	24	24	18000	0,43
655 323 00	655 353 00	655 993 23	655 993 53	80	M20	158	42	23	24	24	18000	0,47
655 324 00	655 354 00	655 993 24	655 993 54	100	M20	98	42	23	24	24	25000	0,44
655 325 00	655 355 00	655 993 25	655 993 55	100	M20	138	42	23	24	24	25000	0,48
655 326 00	655 356 00	655 993 26	655 993 56	100	M20	158	42	23	24	24	25000	0,50
655 327 00	655 357 00	655 993 27	655 993 57	100	M24	98	42	23	24	24	25000	0,61
655 328 00	655 358 00	655 993 28	655 993 58	100	M24	158	42	23	24	24	25000	0,77
655 329 00	655 359 00	655 993 29	655 993 59	100	M24	198	42	23	24	24	25000	0,88

* Static Load

The load figures specified in the table above are guide line values. If these are exceeded, serious permanent deformation or breakage of the plastic base can occur.

These values were established through a series of tests, where with a certain number of levelling feet, a vertical force was applied on the disk for a certain time.

Depend on the application and the load, a safety factor has to be taken into account, so that the permissible load may be below the guide line values stated in the table.

We cannot accept any liability for possible damages which could be caused by the incorrect use of the articulated feet.

General

Articulated Feet 344 and 344.5 are slightly stepped, this makes them look good and easy to clean.

Due to the use of a high grade plastic material and their shape (ribbed base), that serves to spread the weight over a larger area, the feet have a high load bearing capacity.

The rubber pad is fixed to the base with four pins/bores. The rubber pad levels out slightly uneven ground and makes the foot non-slip.