

## Cardan Joints UKM made from Plastic

**Material:** Polyacetal (black).  
Metal caps and crosspiece made from brass.  
Max. operating angle 45°.  
These cardan joints are fixed on the shafts with Allen screws.

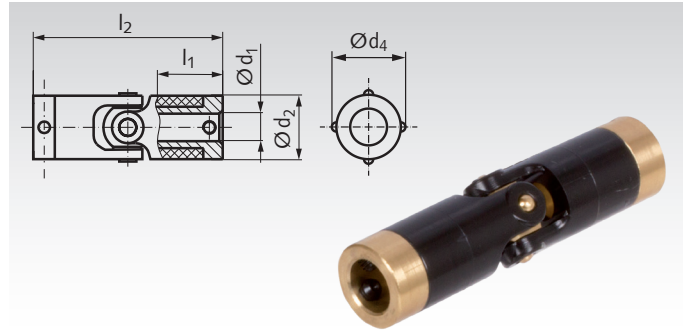

Ordering Details: e.g.: Product No. 630 230 00, Cardan Joint UKM, 2 mm bore

Product No.	$d_1^{+0,03}$ mm	$d_2$ mm	$d_4$ mm	$l_1$ mm	$l_2$ mm	Screws Qty.	Torque Nm	Weight g
630 230 00	2	6,35	7,1	9,3	27,2	1	0,11	3
630 231 00	3	6,35	7,1	9,3	27,2	1	0,11	3
630 234 00	3	9,5	11,1	13,1	37,6	2	0,36	8,5
630 235 00	4	9,5	11,1	13,1	37,6	2	0,36	8,5
630 239 00	4	12,7	14,3	15,7	46,2	2	0,85	17
630 240 00	6	12,7	14,3	15,7	46,2	2	0,85	17
630 243 00	6	15,8	17,5	22,3	67,6	2	1,6	34
630 244 00	8	15,8	17,5	22,3	67,6	2	1,6	34
630 245 00	10	15,8	17,5	22,3	67,6	2	1,6	34

## Double Cardan Joints UKD made from Plastic

**Material:** Polyacetal (black).  
Metal caps and crosspiece made from brass.  
Max. operating angle 45°.  
These cardan joints are fixed on the shafts with Allen screws.



Ordering Details: e.g.: Product No. 630 331 00, Cardan Joint UKD, 3 mm bore

Product No.	$d_1^{+0,03}$ mm	$d_2$ mm	$d_4$ mm	$l_1$ mm	$l_3$ mm	$l_4$ mm	Screws Qty.	Torque max. Nm	Weight g
630 331 00	3	6,35	7,1	9,3	35,3	8,1	1	0,08	3,5
630 334 00	3	9,5	11,1	13,1	50,8	13,2	2	0,16	11,1
630 335 00	4	9,5	11,1	13,1	50,8	13,2	2	0,16	11,1
630 336 00	5	9,5	11,1	13,1	50,8	13,2	2	0,16	11,1
630 339 00	4	12,7	14,3	15,7	62,1	15,9	2	0,59	21,6
630 340 00	6	12,7	14,3	15,7	62,1	15,9	2	0,59	21,6
630 343 00	6	15,8	17,5	22,3	89,8	22,2	2	1,3	42,4
630 344 00	8	15,8	17,5	22,3	89,8	22,2	2	1,3	42,4
630 345 00	10	15,8	17,5	22,3	89,8	22,2	2	1,3	42,4

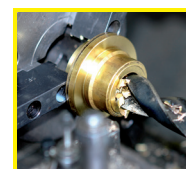

**Reworking within  
24h-service possible.  
Custom made parts  
on request.**