

## ROBA®-Sliding Hubs as Torque Limiters for Chain-, Gear- and Belt Drive-wheels

**Material:** Steel, zinc-phosphated.

ROBA®-sliding hubs are high-quality machine components. They are machined all-round and zinc-phosphated, i.e. rust-proof. They are of fully-closed design.

The sliding hubs are delivered pre-drilled, without setscrew-thread and with the max bush length (for  $b_{max}$ ).

### Required bush length:

The bush length required depends on the width of the component to be joined. To calculate the bush length take the width of the component and add 1.5 times the thickness of the friction lining, plus an additional 0.5mm.

Bush length in mm =  $b + 1.5 \times s + 0.5$ .

**Other bush lengths, customized bores, feather-key grooves and setscrew-threads available at extra charge.**

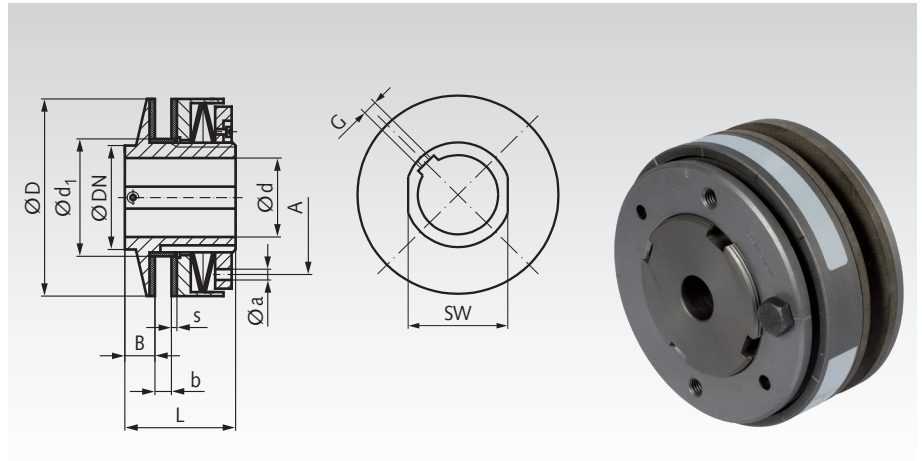

Pictured version for up to 700 Nm max.

Ordering Details: e.g.: Product No. 612 300 00, ROBA-Sliding Hub

Product No.	Size	Torque		Speed max. min <sup>-1</sup>	Clamping Tool A mm	a <sup>-0,2</sup> mm	B mm	b <sub>min.</sub> mm	b <sub>max.</sub> mm	D mm	DN mm	Sprocket Bore d <sub>1</sub> <sup>H8</sup> mm	d max. mm	Pilot Bore mm	Set Screw G mm	L mm	SW mm	Lining S mm	Weight Pre-drilled g
		min. Nm	max. Nm																
612 300 00	0	2	10	8500	37	3	8,5	2	6	45	45	35	20 <sup>1)</sup>	6	M4	33	-	2,5	300
612 310 00	01	6	30	6600	46	5	16	3	8	58	40	40	22	10	M*	45	32	3	600
612 320 00	1	14	70	5600	50	5	17	3	10	68	45	44	25	10	M**	52	41	3	900
612 340 00	2	26	130	4300	67	6	19	4	12	88	58	58	35	14	M***	57	50	3	1600
612 360 00	3	50	250	3300	84	6	21	5	15	115	75	72	45	18	M****	68	65	4	3100
612 380 00	4	110	550	2700	104	7	23	6	18	140	90	85	55	24	M8	78	80	4	5400
612 400 00	5	140	700	2200	125	8	29	8	20	170	102	98	65	28	M8	92	90	5	9000
612 420 00	6	240	1200	1900	150	10	31	8	23	200	120	116	80	38	M8	102	105	5	12400

M\* Up to Ø 12 M4, above Ø 12 M5.

M\*\* Up to Ø12 M4, above Ø12 M5, above Ø17 M6.

M\*\*\* Up to Ø 17 M5, above Ø 17 M6.

M\*\*\*\* Up to Ø 22 M6, above Ø 22 M8.

1) Above Ø19 only with keyway DIN6885/3.

### Replacement Friction Linings and Face Spanners

Matching Product No.	Product No. Spare Part Friction Lining*	Weight g	Product No. Face Spanner	Weight g
612 310 00	612 311 00	8,5	612 312 00	140
612 320 00	612 321 00	13	612 312 00	159
612 340 00	612 341 00	21	612 342 00	240
612 360 00	612 361 00	51	612 342 00	240
612 380 00	612 381 00	79	612 382 00	750
612 400 00	612 401 00	157	612 402 00	1700
612 420 00	612 421 00	216	612 402 00	1700

\* 2 pieces required.

### Technical Explanations

The driving element (sprocket or pulley) is pushed onto the bush and clamped between the friction disks, supported by the pressure plate, the disk springs and the adjusting nut. The harder the disk springs are compressed by the adjusting nuts, the higher is the torque at which the driving element slips. The exact adjustment values for the torque can be found in the table stuck onto the sliding hubs.

The torque values refer to the sprocket version with ground surfaces. Non-ground surfaces lead to faster wear of the friction disks.

Wear due to frequent slipping reduces the set torque.

### Torque – Increase

Changing the series stacking shown to a parallel stacking the maximum torque can be doubled. The minimum torque setting is then approx. 50% of the maximum value.

At sizes 0 - 5, the specified torque can be tripled by the addition of a (third) spring washer. The minimum torque setting is then approx. 65% of the maximum value.

At sizes 3 - 5, this requires a special adjusting nut, and the pressure plate has to be shortened (both against surcharge).

## Sliding Hubs - Minimum Numbers of Chain Wheel Teeth

The sliding hubs FA, FAK, FS and ROBA® are normally used with single-strand chain plate wheels. The minimum numbers of teeth are stated in the tables. They are based on the calculated maximum hub diameters like DIN ISO 606 for chain wheels version B (European type). If there is enough space, for a long chain lifespan, the number of teeth should not be chosen too small. Standard plate wheels can get machined quickly and inexpensively to fit to the slidings hubs. At some hubs and wheels, the length of the sliding bush must also be modified. Price and delivery time on request.

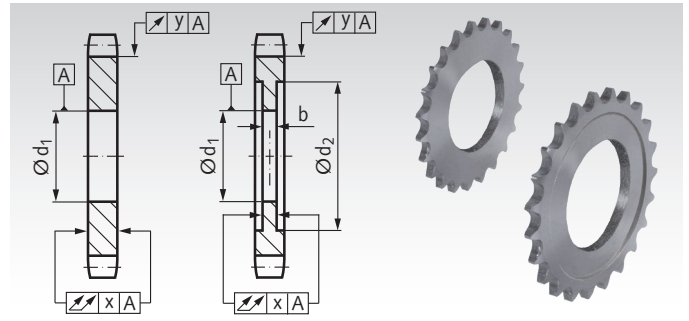

### Minimum Numbers of Teeth for Sliding Hubs FS

Sliding Hub		Chain Size and minimum Number of Teeth										Measures for Reworking				
Size	Hub-Ø mm	06 B 3/8"	08 B 1/2"	10 B 5/8"	12 B 3/4"	16 B 1"	20 B 1 1/4"	24 B 1 1/2"	28 B 1 3/4"	32 B 2"	d <sub>1</sub> <sup>H8</sup> mm	d <sub>2</sub> mm	b mm	x mm	y mm	
120	30	14	10*	10*	-	-	-	-	-	-	21	31	6	0,05	0,1	
180	45	19	15	13*	11*	-	-	-	-	-	34	46	7	0,05	0,1	
250	64	25	20	17	14*	12*	-	-	-	-	41,33	65	9	0,05	0,1	
350	90	33	26	22	18	15	12*	-	-	-	49,28	91	16	0,05	0,1	
500	127	-	35	29	25	19	16*	14*	13*	-	73,10	129	16	0,08	0,15	
700	178	-	-	39	33	25	21	18	16*	15*	104,88	180	28	0,1	0,2	

\* The marked chain plate wheels must be rectified on both sides, see measures d<sub>2</sub>, b, x and y.

### Minimum Numbers of Teeth for Sliding Hubs FA, FAK and ROBA®

Sliding Hub		Chain Size and minimum Number of Teeth										Measures for Reworking				
Size	Hub-Ø mm	06 B 3/8"	08 B 1/2"	10 B 5/8"	12 B 3/4"	16 B 1"	20 B 1 1/4"	24 B 1 1/2"	28 B 1 3/4"	32 B 2"	d <sub>1</sub> <sup>H8</sup> mm	d <sub>2</sub> mm	b mm	x mm	y mm	
00	30	14	11*	10*	-	-	-	-	-	-	21	31	6	0,05	0,1	
0	45	19	15*	13*	11*	-	-	-	-	-	35	46	6	0,05	0,1	
01	58	23	18	15*	13*	11*	-	-	-	-	40	59	8	0,05	0,1	
1	68	26	21	17	15*	12*	-	-	-	-	44	68	10	0,05	0,1	
2	88	33	26	21	18	14*	12*	-	-	-	58	89	12	0,05	0,1	
3	115	-	32	27	22	18*	15*	13*	-	-	72	116	15	0,08	0,15	
4	140	-	-	32	27	21	17*	15*	13*	-	85	142	18	0,08	0,15	
5	170	-	-	38	32	24	20	18*	16*	15*	98	172	20	0,08	0,15	
6	200	-	-	-	37	28	23	20*	18*	16*	116	202	23	0,1	0,2	
7	240	-	-	-	43	33	27	23	20*	18*	144	242	25	0,1	0,2	
8	285	-	-	-	-	39	32	27	24*	21*	170	287	25	0,1	0,2	

\* The marked chain plate wheels must be rectified on both sides, see measures d<sub>2</sub>, b, x and y.

### Standard Widths of Chain Wheels and Chain Link Heights like DIN ISO 606 for Type B

DIN ISO No.	06 B-1	08 B-1	10 B-1	12 B-1	16 B-1	20 B-1	24 B-1	28 B-1	32 B-1
Pitch in inch	3/8"	1/2"	5/8"	3/4"	1"	1 1/4"	1 1/2"	1 3/4"	2"
Wheel width in mm	5,3	7,2	9,1	11,1	16,2	18,5	24,1	29,4	29,4
Link height in mm	8,26	11,81	14,73	16,13	21,08	26,42	33,40	37,08	42,29

### Choosing the Number of Teeth

The number of teeth should not be set too small. The smaller the number of teeth is, the higher is the polygon effect and the rotation in the chain joints. This increases the chain stress. Wheels from 25 teeth and more enable a long operating life of the chain. Preferred numbers of teeth like DIN ISO 606: 17, 19, 21, 23, 25, 38, 57, 76, 95 and 114.

ANSI chain wheels: The chain wheels of the American type (DIN ISO sizes 35, 40, 50, 60 and others, formerly named ASA 06C, 08A, 10A, 12A, ...) have higher links. And at most sizes, the wheel width is different to the European standard B. So, the minimum number of teeth may be different to the stated B type wheels. The maximum allowed hub diameter must be calculated individually.

Total outside diameter: The approximate outer diameter is the sum of the pitch circle diameter of the standard chain wheel and the height of the link (see third table above).

### Note for reworking and mounting

Often, the chain plate wheels must only be bored with tolerance H8, fitting to the sliding bush. But if the wheel width is larger than the space between the friction discs of the sliding hub, the wheel must be rectified equally on both sides. The bush length must be checked and may be needed to modify. By sliding at overload, the contact surfaces will be smoothed. This will change the torque setting. If the application requires an exactly torque setting, a fine reworking of the contact surfaces is recommended, up to a maximum roughness of Ra = 0,8 µm. All contact surfaces, including the friction discs, must be mounted in grease-free condition.

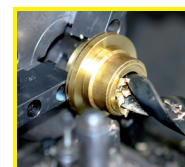

**Reworking within  
24h-service possible.  
Custom made parts  
on request.**