

Sliding Hubs FA-K as Torque Limiters, with Clamp Hub

Material: Steel, zinc-plated and chromated.

- Clamp hub version.
- The slipping torque can be adjusted with common assembly tools for screws, also after mounting.
- By mounting an additional springs the torque range can be increased (additional spring has to be ordered separately).
- The hubs are delivered with pilot bore and max. bush length. Customized bores, keyways and bush lengths at extra charge.

Required bush length:

The bush length required depends on the width of the component to be joined. To calculate the bush length take the width of the component and add 1.5 times the thickness of the friction disc, plus an additional 0.5mm.

Bush length in mm = $1.5 \times s + b + 0.5$.

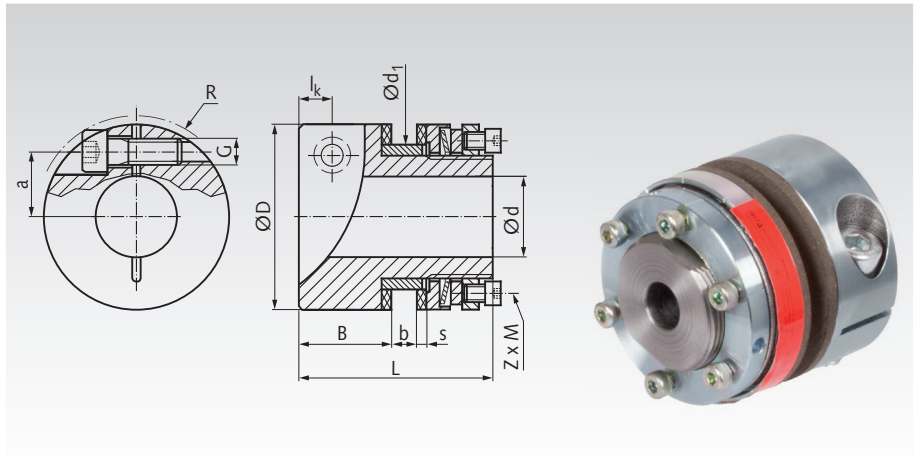

Ordering Details: e.g.: Product No. 612 110 10, Sliding Hub FA-K size 0

Product No.	Size	Torque range		Speed max. min ⁻¹	Bore		D mm	B mm	Bore of Sprocket d ₁ ^{H8} mm	Width		Bush length		s mm	L mm	Screws Z x M mm	Weight prebored kg
		1 Spring ¹⁾ Nm	2 Springs ²⁾ Nm		Pilot mm	d _{max.} mm				b _{min.} mm	b _{max.} mm	min. mm	max. mm				
612 110 10	0	2 - 10	4 - 20	8500	10	22	45	21,5	35	2	6	6	10	2,5	46	6x M4	0,3
612 111 00	01	5 - 35	10 - 70	6600	10	25	58	26	40	3	8	8	13	3	55	6x M4	0,6
612 111 10	1	20 - 75	40 - 150	5600	18	28	68	30	44	3	10	8	15	3	65	6x M5	0,9
612 112 00	2	25 - 140	50 - 280	4300	18	40	88	34	58	4	12	9	17	3	72	6x M6	1,8

Clamp Screw Dimensions and Fastening Torque

Size	R mm	G mm	T _A Nm	l _k mm	a mm
0	50	M6	16	8	16
01	62	M8	41	10	19
1	74	M10	83	12	22
2	93	M12	145	14	30

¹⁾ With one disc spring (standard version).

²⁾ With second disc spring (order separately).

Replacement Friction Discs and additional Disc Springs

Matching Sliding Hub Product No.	Size	Outer Ø mm	Product No. Friction Disc ¹⁾	Weight g	Product No. Disc Spring	Weight g
612 110 10	0	45	612 100 11	3	612 100 12	5
612 111 00	01	58	612 101 01	10	612 101 02	10
612 111 10	1	68	612 101 11	13	612 101 12	20
612 112 00	2	88	612 102 01	21	612 102 02	40

¹⁾ 2 pieces required.

Remarks to the versions

The pictures above show size 01 to 2. Size 0 is on the left side without hub.

Customized bores, keyways and bush lengths are available at extra charge.



Technical Explanations

The driving element (sprocket or pulley) is pushed onto the bush and clamped between the friction discs, supported by the round adjusting nut, the pressure plate, preload screws and the disk spring. The harder the disk spring is compressed by the pressure plate, the higher is the torque at which the driving element slips. The exact adjustment values for the torque can be found in the table stuck onto the sliding hubs.

Torque – Increase

The torque values refer to the sprocket version with ground surfaces. Non-ground surfaces lead to faster wear of the friction disks.

Wear due to frequent slipping reduces the set torque.

At all sizes, the specified torque can be doubled by the addition of a (second) disc spring. The torque ranges with one or two disc springs are shown in the table.

Operating Instructions at www.maedler.de in the section Downloads

Sliding Hubs - Minimum Numbers of Chain Wheel Teeth

The sliding hubs FA, FA-K, FS and ROBA® are normally used with single-strand chain plate wheels. The minimum numbers of teeth are stated in the tables. They are based on the calculated maximum hub diameters like DIN ISO 606 for chain wheels version B (European type). If there is enough space, for a long chain lifespan, the number of teeth should not be chosen too small. Standard plate wheels can get machined quickly and inexpensively to fit to the slidings hubs. At some hubs and wheels, the length of the sliding bush must also be modified. Price and delivery time on request.

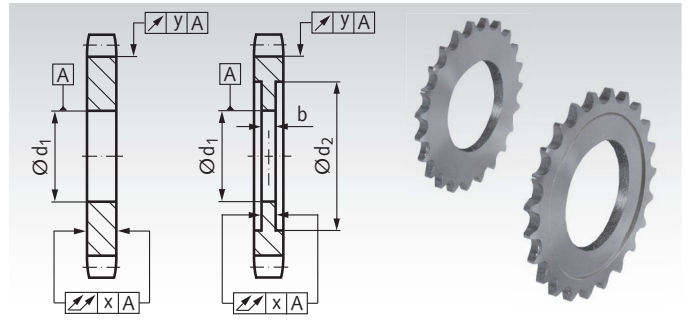

Minimum Numbers of Teeth for Sliding Hubs FS

Sliding Hub		Chain Size and minimum Number of Teeth										Measures for Reworking				
Size	Hub-Ø mm	06 B 3/8"	08 B 1/2"	10 B 5/8"	12 B 3/4"	16 B 1"	20 B 1 1/4"	24 B 1 1/2"	28 B 1 3/4"	32 B 2"	d ₁ ^{H8} mm	d ₂ mm	b mm	x mm	y mm	
120	30	14	10*	10*	-	-	-	-	-	-	21	31	6	0,05	0,1	
180	45	19	15	13*	11*	-	-	-	-	-	34	46	7	0,05	0,1	
250	64	25	20	17	14*	12*	-	-	-	-	41,33	65	9	0,05	0,1	
350	90	33	26	22	18	15	12*	-	-	-	49,28	91	16	0,05	0,1	
500	127	-	35	29	25	19	16*	14*	13*	-	73,10	129	16	0,08	0,15	
700	178	-	-	39	33	25	21	18	16*	15*	104,88	180	28	0,1	0,2	

* The marked chain plate wheels must be rectified on both sides, see measures d₂, b, x and y.

Minimum Numbers of Teeth for Sliding Hubs FA, FA-K and ROBA®

Sliding Hub		Chain Size and minimum Number of Teeth										Measures for Reworking				
Size	Hub-Ø mm	06 B 3/8"	08 B 1/2"	10 B 5/8"	12 B 3/4"	16 B 1"	20 B 1 1/4"	24 B 1 1/2"	28 B 1 3/4"	32 B 2"	d ₁ ^{H8} mm	d ₂ mm	b mm	x mm	y mm	
00	30	14	11*	10*	-	-	-	-	-	-	21	31	6	0,05	0,1	
0	45	19	15*	13*	11*	-	-	-	-	-	35	46	6	0,05	0,1	
01	58	23	18	15*	13*	11*	-	-	-	-	40	59	8	0,05	0,1	
1	68	26	21	17	15*	12*	-	-	-	-	44	68	10	0,05	0,1	
2	88	33	26	21	18	14*	12*	-	-	-	58	89	12	0,05	0,1	
3	115	-	32	27	22	18*	15*	13*	-	-	72	116	15	0,08	0,15	
4	140	-	-	32	27	21	17*	15*	13*	-	85	142	18	0,08	0,15	
5	170	-	-	38	32	24	20	18*	16*	15*	98	172	20	0,08	0,15	
6	200	-	-	-	37	28	23	20*	18*	16*	116	202	23	0,1	0,2	
7	240	-	-	-	43	33	27	23	20*	18*	144	242	25	0,1	0,2	
8	285	-	-	-	-	39	32	27	24*	21*	170	287	25	0,1	0,2	

* The marked chain plate wheels must be rectified on both sides, see measures d₂, b, x and y.

Standard Widths of Chain Wheels and Chain Link Heights like DIN ISO 606 for Type B

DIN ISO No.	06 B-1	08 B-1	10 B-1	12 B-1	16 B-1	20 B-1	24 B-1	28 B-1	32 B-1
Pitch in inch	3/8"	1/2"	5/8"	3/4"	1"	1 1/4"	1 1/2"	1 3/4"	2"
Wheel width in mm	5,3	7,2	9,1	11,1	16,2	18,5	24,1	29,4	29,4
Link height in mm	8,26	11,81	14,73	16,13	21,08	26,42	33,40	37,08	42,29

Choosing the Number of Teeth

The number of teeth should not be set too small. The smaller the number of teeth is, the higher is the polygon effect and the rotation in the chain joints. This increases the chain stress. Wheels from 25 teeth and more enable a long operating life of the chain. Preferred numbers of teeth like DIN ISO 606: 17, 19, 21, 23, 25, 38, 57, 76, 95 and 114.

ANSI chain wheels: The chain wheels of the American type (DIN ISO sizes 35, 40, 50, 60 and others, formerly named ASA 06C, 08A, 10A, 12A, ...) have higher links. And at most sizes, the wheel width is different to the European standard B. So, the minimum number of teeth may be different to the stated B type wheels. The maximum allowed hub diameter must be calculated individually.

Total outside diameter: The approximate outer diameter is the sum of the pitch circle diameter of the standard chain wheel and the height of the link (see third table above).

Note for reworking and mounting

Often, the chain plate wheels must only be bored with tolerance H8, fitting to the sliding bush. But if the wheel width is larger than the space between the friction discs of the sliding hub, the wheel must be rectified equally on both sides. The bush length must be checked and may be needed to modify. By sliding at overload, the contact surfaces will be smoothed. This will change the torque setting. If the application requires an exactly torque setting, a fine reworking of the contact surfaces is recommended, up to a maximum roughness of Ra = 0,8 µm. All contact surfaces, including the friction discs, must be mounted in grease-free condition.

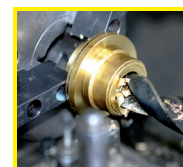

**Reworking within
24h-service possible.
Custom made parts
on request.**