

Sliding Hubs FS

Material:

Hub: Steel, zinc-plated and yellow passivated. Spring: Steel, black.

The sliding hubs can be delivered ex stock, pre-drilled with a bush of the length in **bold print**.

Required bush length:

The required bush length depends on the width of the component to be joined.

Up to Prod. No. 612 006 00:

Bush length 4.2 mm for a component width of 5.3 to 6.0 mm.

From Prod. No. 612 010 00:

Bush length in mm = 1.5 x s + b.

Other bush lengths and customized bores or feather-key grooves against extra charge.

Ordering Details: e.g.: Product No. 612 000 00, Sliding Hub FS

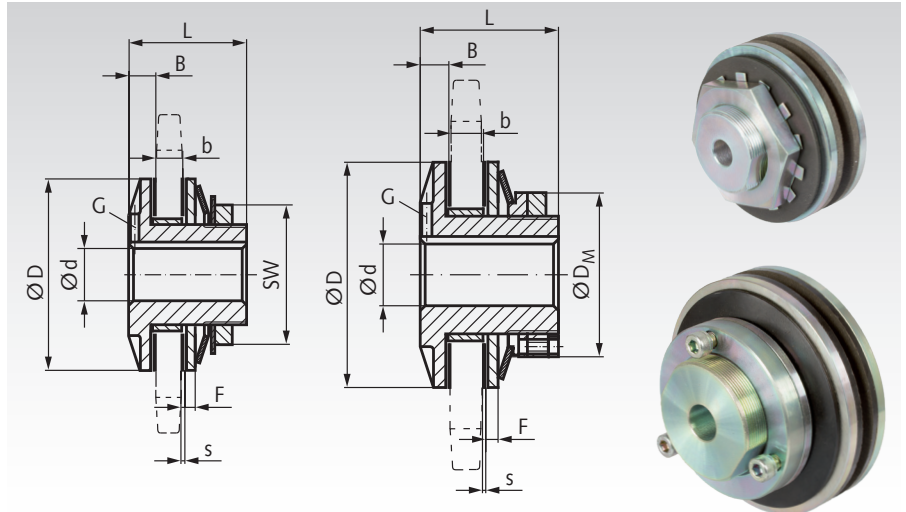

Up to No. 612 040 00
with hexagonal nut

From No. 612 050 00
with round nut

Product No	Size	Springs Qty.	Torque		Speed max. min ⁻¹	Bore d				Bore of Sprocket d ₁ H ⁸ mm	b _{max.} mm	Available Bush Lengths					SW mm	D _M mm	G mm	Weight prebored kg	
			min. Nm	max. Nm		Pilot mm	max. mm	D mm	B mm			#1 mm	#2 mm	#3 mm	F mm	s mm					L mm
612 000 00**	120-1	2	0,5	5	10000	3,7	10	30	8,5	21,0	6	4,2	-	-	2	2,5	31	27	-	M4	0,15
612 001 00**	120-2	4	1	10	10000	3,7	10	30	8,5	21,0	6	4,2	-	-	2	2,5	31	27	-	M4	0,17
612 005 00**	180-1	1	2	10	8500	5,7	20	45	8,5	34,0	7	4,2	-	-	2	2,5	33	41	-	M4	0,35
612 006 00**	180-2	2	4	20	8500	5,7	20	45	8,5	34,0	7	4,2	-	-	2	2,5	33	41	-	M4	0,37
612 010 00	250-1	1	7	34	3000	10	22	64	16	41,33	9	10,3	12,2	14	5	4	48	50	-	M5	0,70
612 020 00	250-2	2	14	68	3000	10	22	64	16	41,33	9	10,3	12,2	14	5	4	48	50	-	M5	0,72
612 030 00	350-1	1	20	90	2500	13	25	90	19	49,28	16	10,3	13,7	21	5	4	62	60	-	M6	1,36
612 040 00	350-2	2	40	180	2500	13	25	90	19	49,28	16	10,3	13,7	21	5	4	62	60	-	M6	1,40
612 050 00	500-1	1	50	300	1600	19	40	127	21	73,10	16	16	19,5	21	6	4	76	-	92	M8	3,36
612 060 00	500-2	2	100	600	1600	19	40	127	21	73,10	16	16	19,5	21	6	4	76	-	92	M8	3,70
612 070 00	700-1	1	115	690	1200	24	60	178	25	104,88	28	17	20,6	22	6	5	98	-	133	M10	8,60
612 080 00	700-2	2	230	1360	1200	24	60	178	25	104,88	28	17	20,6	22	6	5	98	-	133	M10	8,90

* ca. -dimensions.

** With round lock washer without edges.

Size	Product No.		Product No.	Weight g	Product No.		Product No.	Weight g	Product No.		Product No.	Weight g	Product No.		Product No.	Weight g
	Friction Disc*	Weight g			Disc Spring	Threaded Ring or Adjusting Screw			Weight g	Bushes Length 1			Weight g	Bushes Length 2		
120-1	612 003 00	2	612 004 00	3	612 000 07	9	612 000 02	3	-	-	-	-	-	-	-	-
120-2	612 003 00	2	612 004 00	3	612 000 07	9	612 000 02	3	-	-	-	-	-	-	-	-
180-1	612 007 00	4	612 008 00	5	612 005 07	44	612 005 02	10	-	-	-	-	-	-	-	-
180-2	612 007 00	4	612 008 00	5	612 005 07	44	612 005 02	10	-	-	-	-	-	-	-	-
250-1	612 015 00	12	612 016 00	15	612 017 00	80	612 012 00	25	612 013 00	40	612 014 00	50	-	-	-	-
250-2	612 015 00	12	612 016 00	15	612 017 00	80	612 012 00	25	612 013 00	40	612 014 00	50	-	-	-	-
350-1	612 035 00	30	612 036 00	45	612 037 00	140	612 032 00	37	612 033 00	44	612 034 00	85	-	-	-	-
350-2	612 035 00	30	612 036 00	45	612 037 00	140	612 032 00	37	612 033 00	44	612 034 00	85	-	-	-	-
500-1	612 055 00	60	612 056 00	120	612 057 00	320	612 052 00	97	612 053 00	135	612 054 00	200	-	-	-	-
500-2	612 055 00	60	612 056 00	120	612 057 00	320	612 052 00	97	612 053 00	135	612 054 00	200	-	-	-	-
700-1	612 075 00	140	612 076 00	280	612 077 00	660	612 072 00	103	612 073 00	183	612 074 00	300	-	-	-	-
700-2	612 075 00	140	612 076 00	280	612 077 00	660	612 072 00	103	612 073 00	183	612 074 00	300	-	-	-	-

* 2 pieces required.

General

The sliding hubs FS are safety devices working on the positive principle. In case of overload, the disk clamped between the friction disks starts slipping and thus keeps the torque within the permissible limits. The power reengages automatically as soon as normal load is reached again. The hubs are cadmium plated for rust-protection. The drive disk is mounted on a maintenance-free bush made from sintered metal. Up to product no. 612 040 00, the torque is set with a hexagon adjusting screw. From product no. 612 050 00 the torque is set with a threaded ring with 3 hexagon nuts. On first use, the sliding hubs should be run in for about 250 turns at a speed of 60 min⁻¹. This should be done at a hub setting of 70-80% of the max. torque for one plate disk. Wear due to frequent slipping reduces the set torque. The figures in the table are calculated for dry operation.

With oil the load can be reduced by 50%. Higher torques, at the same outer diameter, can be achieved with a second spring disk.

Exception: Product No. 612 000 00 has 2 springs, Product No. 612 001 00 has 4 springs.

Mounting instruction at www.maedler.de in the section Downloads.

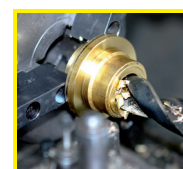

Reworking within 24h-service possible. Custom made parts on request.

Sliding Hubs - Minimum Numbers of Chain Wheel Teeth

The sliding hubs FA, FAK, FS and ROBA® are normally used with single-strand chain plate wheels. The minimum numbers of teeth are stated in the tables. They are based on the calculated maximum hub diameters like DIN ISO 606 for chain wheels version B (European type). If there is enough space, for a long chain lifespan, the number of teeth should not be chosen too small. Standard plate wheels can get machined quickly and inexpensively to fit to the slidings hubs. At some hubs and wheels, the length of the sliding bush must also be modified. Price and delivery time on request.

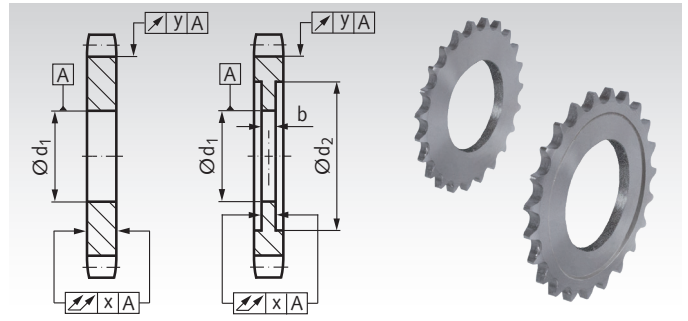

Minimum Numbers of Teeth for Sliding Hubs FS

Sliding Hub		Chain Size and minimum Number of Teeth										Measures for Reworking				
Size	Hub-Ø mm	06 B 3/8"	08 B 1/2"	10 B 5/8"	12 B 3/4"	16 B 1"	20 B 1 1/4"	24 B 1 1/2"	28 B 1 3/4"	32 B 2"	d ₁ ^{H8} mm	d ₂ mm	b mm	x mm	y mm	
120	30	14	10*	10*	-	-	-	-	-	-	21	31	6	0,05	0,1	
180	45	19	15	13*	11*	-	-	-	-	-	34	46	7	0,05	0,1	
250	64	25	20	17	14*	12*	-	-	-	-	41,33	65	9	0,05	0,1	
350	90	33	26	22	18	15	12*	-	-	-	49,28	91	16	0,05	0,1	
500	127	-	35	29	25	19	16*	14*	13*	-	73,10	129	16	0,08	0,15	
700	178	-	-	39	33	25	21	18	16*	15*	104,88	180	28	0,1	0,2	

* The marked chain plate wheels must be rectified on both sides, see measures d₂, b, x and y.

Minimum Numbers of Teeth for Sliding Hubs FA, FAK and ROBA®

Sliding Hub		Chain Size and minimum Number of Teeth										Measures for Reworking				
Size	Hub-Ø mm	06 B 3/8"	08 B 1/2"	10 B 5/8"	12 B 3/4"	16 B 1"	20 B 1 1/4"	24 B 1 1/2"	28 B 1 3/4"	32 B 2"	d ₁ ^{H8} mm	d ₂ mm	b mm	x mm	y mm	
00	30	14	11*	10*	-	-	-	-	-	-	21	31	6	0,05	0,1	
0	45	19	15*	13*	11*	-	-	-	-	-	35	46	6	0,05	0,1	
01	58	23	18	15*	13*	11*	-	-	-	-	40	59	8	0,05	0,1	
1	68	26	21	17	15*	12*	-	-	-	-	44	68	10	0,05	0,1	
2	88	33	26	21	18	14*	12*	-	-	-	58	89	12	0,05	0,1	
3	115	-	32	27	22	18*	15*	13*	-	-	72	116	15	0,08	0,15	
4	140	-	-	32	27	21	17*	15*	13*	-	85	142	18	0,08	0,15	
5	170	-	-	38	32	24	20	18*	16*	15*	98	172	20	0,08	0,15	
6	200	-	-	-	37	28	23	20*	18*	16*	116	202	23	0,1	0,2	
7	240	-	-	-	43	33	27	23	20*	18*	144	242	25	0,1	0,2	
8	285	-	-	-	-	39	32	27	24*	21*	170	287	25	0,1	0,2	

* The marked chain plate wheels must be rectified on both sides, see measures d₂, b, x and y.

Standard Widths of Chain Wheels and Chain Link Heights like DIN ISO 606 for Type B

DIN ISO No.	06 B-1	08 B-1	10 B-1	12 B-1	16 B-1	20 B-1	24 B-1	28 B-1	32 B-1
Pitch in inch	3/8"	1/2"	5/8"	3/4"	1"	1 1/4"	1 1/2"	1 3/4"	2"
Wheel width in mm	5,3	7,2	9,1	11,1	16,2	18,5	24,1	29,4	29,4
Link height in mm	8,26	11,81	14,73	16,13	21,08	26,42	33,40	37,08	42,29

Choosing the Number of Teeth

The number of teeth should not be set too small. The smaller the number of teeth is, the higher is the polygon effect and the rotation in the chain joints. This increases the chain stress. Wheels from 25 teeth and more enable a long operating life of the chain. Preferred numbers of teeth like DIN ISO 606: 17, 19, 21, 23, 25, 38, 57, 76, 95 and 114.

ANSI chain wheels: The chain wheels of the American type (DIN ISO sizes 35, 40, 50, 60 and others, formerly named ASA 06C, 08A, 10A, 12A, ...) have higher links. And at most sizes, the wheel width is different to the European standard B. So, the minimum number of teeth may be different to the stated B type wheels. The maximum allowed hub diameter must be calculated individually.

Total outside diameter: The approximate outer diameter is the sum of the pitch circle diameter of the standard chain wheel and the height of the link (see third table above).

Note for reworking and mounting

Often, the chain plate wheels must only be bored with tolerance H8, fitting to the sliding bush. But if the wheel width is larger than the space between the friction discs of the sliding hub, the wheel must be rectified equally on both sides. The bush length must be checked and may be needed to modify. By sliding at overload, the contact surfaces will be smoothed. This will change the torque setting. If the application requires an exactly torque setting, a fine reworking of the contact surfaces is recommended, up to a maximum roughness of Ra = 0,8 µm. All contact surfaces, including the friction discs, must be mounted in grease-free condition.

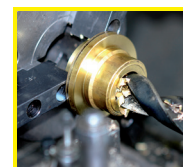

**Reworking within
24h-service possible.
Custom made parts
on request.**