

## Slip Clutches R2 and R6

### Type A - Concentric Arrangement

as sliding hub for a driving wheel

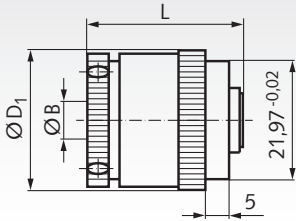

### Type B - Axial Arrangement

to connect two shafts

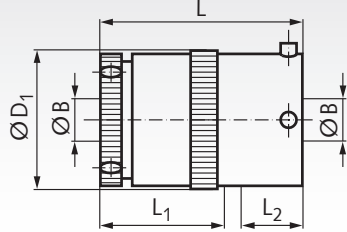

### Type C - Axial Arrangement

to connect two shafts with shaft misalignment

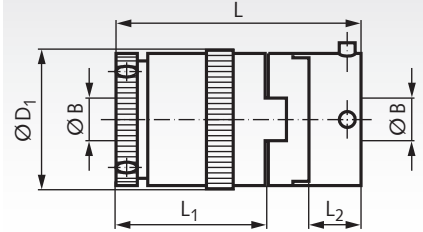

**Material:** Housing made of aluminium alloy with iridite NCP finish. Inner Hub made of steel.  
Max. slip-speed 1,000 min<sup>-1</sup>. Torsional backlash of the coupling below 2°.

**Ordering Details:** e.g.: Product No. 610 403 00, Friction Clutch, Type A, 6 mm Bore

Product No.	Type	Number of Friction Plates Pieces	L mm	L <sub>1</sub> mm	L <sub>2</sub> mm	D <sub>1</sub> mm	Bore B <sup>+0.03</sup> mm	Set Screw Size and Arrangement	Weight g	Product No. Spare Part Insert	Weight g
610 403 00	A	2	26,4	-	-	25,8	6	M 3x3,	37	-	-
610 404 00	A	2	26,4	-	-	25,8	8	2x90°	37	-	-
610 408 00	A	6	32,4	-	-	25,8	6	only	48	-	-
610 409 00	A	6	32,4	-	-	25,8	8	at 1 Side	48	-	-
610 423 00	B	2	36	25	9	25,8	6	M 3x3, 2x90°	50	-	-
610 424 00	B	2	36	25	9	25,8	8	at Side 1	50	-	-
610 428 00	B	6	42,5	31	9	25,8	6	M 4x4, 2x90°	61	-	-
610 429 00	B	6	42,5	31	9	25,8	8	at Side 2	61	-	-
610 443 00	C	2	46,5	25	8,6	25,8	6	M 3x3, 2x90°	57	601 244 00	2,7
610 444 00	C	2	46,5	25	8,6	25,8	8	at Side 1	57	601 244 00	2,7
610 448 00	C	6	53,4	31	8,6	25,8	6	M 4x4, 2x90°	83	601 244 00	2,7
610 449 00	C	6	53,4	31	8,6	25,8	8	at Side 2	83	601 244 00	2,7

#### Sectional drawing of a slip clutch with 6 clutch plates

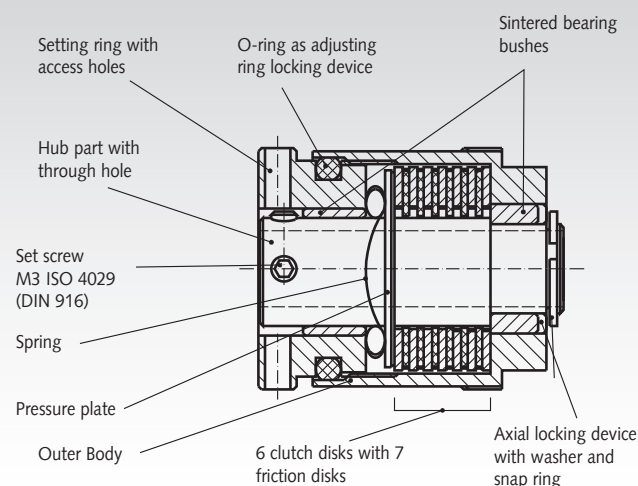

**Torque range with 2 friction plates 2.4 Ncm to 53.8 Ncm.** Dissipation at 20°C ambient temperature up to 7 watts. **Torque range with 6 friction plates 7.8 Ncm to 132.4 Ncm.** Dissipation at 20°C ambient temperature up to 8.6 Watt. Maximum permissible temperature at the surface for all sizes during operation 80°C.

An adjusting ring - screwed to the outer body - serves to adjust the torque. This ring acts via a disk spring onto the clutch or friction disks. Two sintered bearing sleeves serve as bearing housing to inner component. An O-Ring seals the hub off against dirt and with its friction force it also makes sure that the adjusting ring is not moved unintentionally. **The power can be connected to either the hub or the housing.**

Depending on the specific application, the friction clutch can be employed as torque limiter, as overrunning clutch or as brake. As the generation of heat is basically a function including the slip torque and the employed torque, the following formula was derived:

$$\frac{\text{Slippage (min}^{-1}) \times \text{Torque (Ncm)}}{955} = \text{Heat Dissipation in Watts}$$

As the connected components (shafts, gears, etc.) support the heat dissipation, in case of doubt please calculate the effective surface temperature under adverse operating conditions. The permissible temperatures are stated above.

**Special designs:** the modular-design principle used in slip clutches leads to many different designs and possible connecting parts, e.g., special flanges and other components, according to drawings.

**ATTENTION:** the adjusting screws can damage the adjusting ring if they are loosened too far. 3/4 to 1 turn is sufficient.

#### Concentric mounting (type A)

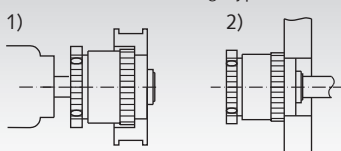

- 1) Pulley or sprocket (bondage recommend), shaft also used as bearing.
- 2) Mounted to the housing as permanent brake and shaft bearing.
- 3) Connection electronic engine and gear box, with assembly-related shaft misalignment.

#### Axial arrangement, both shafts outside (type C)

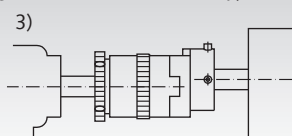

#### Axial arrangement, one shaft outside (type B)

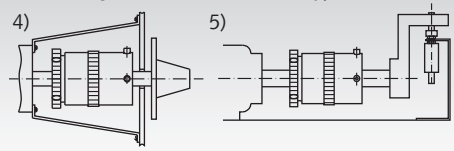

- 4) Shaft of a multi-turn potentiometer divided with slip clutches. No overrevving.
- 5) Protecting a lever key from damage using a slip clutch.