

## Elastic Couplings RNK, backlash-free, with clamps

**Material:** Hubs made from Aluminium.

Spider made from Polyurethane.

Size 5 - 9: Shore hardness 92° (yellow or white).

From size 14: Shore hardness 98° (red).

- Zero backlash, insertable elastic coupling.
- With clamps, ready-to-install for rapid mounting.
- Many different sizes and diameters available.
- From size 14 can be exchanged with couplings RN, RNH and couplings from many other suppliers.
- On request with soft inserts.

Temperature range: -30°C to +90°C.

Ordering Details: e.g.: Product No. 605 405 01, Coupling RNK, 1mm bore

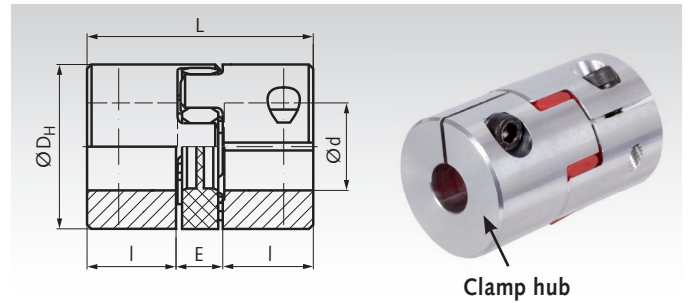

Product No.	Size	Torque max. Nm	Bore d <sup>H7</sup> 1) mm	Bore max. 2) mm	D <sub>H</sub> 3) mm	L mm	I mm	E mm	maximum misalignment 4)			Speed max. min <sup>-1</sup> 5)	Weight approx. g
									Angular Degrees	Radial mm	Axial mm		
605 405 01	5	-	1*	5	10	15	5	5	1	0,06	+0,4/-0,2	38000	2
605 405 03	5	0,4	3	5	10	15	5	5	1	0,06	+0,4/-0,2	38000	2
605 405 04	5	0,5	4	5	10	15	5	5	1	0,06	+0,4/-0,2	38000	2
605 407 03	7	-	3*	7	14	22	7	8	1	0,1	+0,6/-0,3	27000	6
605 407 05	7	0,95	5	7	14	22	7	8	1	0,1	+0,6/-0,3	27000	6
605 407 06	7	1	6	7	14	22	7	8	1	0,1	+0,6/-0,3	27000	6
605 409 03	9	-	3*	11	20	30	10	10	1	0,13	+0,8/-0,4	19000	17
605 409 09	9	2,6	9	11	20	30	10	10	1	0,13	+0,8/-0,4	19000	17
605 409 10	9	2,7	10	11	20	30	10	10	1	0,13	+0,8/-0,4	19000	17
605 409 11	9	2,8	11	11	20	30	10	10	1	0,13	+0,8/-0,4	19000	17
605 414 03	14	-	3*	16	30	35	11	13	0,9	0,09	+1,0/-0,5	13000	41
605 414 11	14	5,6	11	16	30	35	11	13	0,9	0,09	+1,0/-0,5	13000	41
605 414 14	14	6,1	14	16	30	35	11	13	0,9	0,09	+1,0/-0,5	13000	41
605 414 16	14	6,5	16	16	30	35	11	13	0,9	0,09	+1,0/-0,5	13000	41
605 419 05	19	-	5*	22	40	66	25	16	0,9	0,06	+1,2/-0,5	10000	150
605 419 14	19	29	14	22	40	66	25	16	0,9	0,06	+1,2/-0,5	10000	150
605 419 16	19	30	16	22	40	66	25	16	0,9	0,06	+1,2/-0,5	10000	150
605 419 19	19	32	19	22	40	66	25	16	0,9	0,06	+1,2/-0,5	10000	150
605 424 05	24	-	5*	32	55	78	30	18	0,9	0,1	+1,4/-0,5	7000	320
605 424 16	24	38	16	32	55	78	30	18	0,9	0,1	+1,4/-0,5	7000	320
605 424 19	24	40	19	32	55	78	30	18	0,9	0,1	+1,4/-0,5	7000	320
605 424 24	24	44	24	32	55	78	30	18	0,9	0,1	+1,4/-0,5	7000	320
605 428 10	28	-	10*	38	65	90	35	20	0,9	0,11	+1,5/-0,7	6000	470
605 428 24	28	91	24	38	65	90	35	20	0,9	0,11	+1,5/-0,7	6000	470
605 428 28	28	97	28	38	65	90	35	20	0,9	0,11	+1,5/-0,7	6000	470
605 428 32	28	101	32	38	65	90	35	20	0,9	0,11	+1,5/-0,7	6000	470
605 438 10	38	-	10*	45	80	114	45	24	0,9	0,12	+1,8/-0,7	5000	960
605 438 28	38	110	28	45	80	114	45	24	0,9	0,12	+1,8/-0,7	5000	960
605 438 32	38	114	32	45	80	114	45	24	0,9	0,12	+1,8/-0,7	5000	960
605 438 38	38	120	38	45	80	114	45	24	0,9	0,12	+1,8/-0,7	5000	960
605 442 20	42	-	20*	50	95	126	50	26	0,9	0,14	+2,0/-1	4000	1700
605 442 32	42	265	32	50	95	126	50	26	0,9	0,14	+2,0/-1	4000	1700
605 442 38	42	285	38	50	95	126	50	26	0,9	0,14	+2,0/-1	4000	1700
605 442 45	42	300	45	50	95	126	50	26	0,9	0,14	+2,0/-1	4000	1700
605 448 20	48	-	20*	55	105	140	56	28	0,9	0,16	+2,1/-1	3750	2500
605 448 38	48	445	38	55	105	140	56	28	0,9	0,16	+2,1/-1	3750	2500
605 448 45	48	480	45	55	105	140	56	28	0,9	0,16	+2,1/-1	3750	2500
605 448 50	48	495	50	55	105	140	56	28	0,9	0,16	+2,1/-1	3750	2500

1) Standard bores (both sides). Bores with \* are pilot bores (not H7). The torque depends on the size of the finished bore.

2) Different bores (even one-sided) as well feather keyways, available against surcharge.

3) Follow the breakdown Ø as per the table below (screw head protrudes over diameter D<sub>H</sub> or D).

4) Maximal values are mutually exclusive. 5) Above 30m/s, dynamic balancing is required.

### Further details and dimensions

Size	Torque <sup>1)</sup>		Screw size DIN 912	Tightening Torque Nm	Max Ø <sup>2)</sup> mm	Torsion spring stiffness		Moment of inertia <sup>3)</sup> 10 <sup>-6</sup> Kg·m <sup>2</sup>
	T <sub>kN</sub> Nm	T <sub>kmax</sub> Nm				static Nm/rad	dynam. Nm/rad <sup>4)</sup>	
5	0,5	1,0	M1,6	0,25	11,4	5,2	16	0,034
7	1,2	2,4	M2	0,37	15,0	14,3	43	0,196
9	3,0	6,0	M2,5	0,75	23,4	31	95	1,08
14	12,5	25	M3	1,4	32,2	172	513	5,7
19	17	34	M6	11	47,0	860	2580	36
24	60	120	M6	11	56,4	2060	6189	150
28	160	320	M8	25	72,6	3440	10314	330
38	325	650	M8	25	83,0	7160	21486	960
42	450	900	M10	70	95	19200	37690	1820
48	525	1050	M12	120	105	22370	45620	3060

1) Nominal moment and max. moment for the design. The permitted torque for each bore size may not be exceeded.

2) Screw head protrudes past diameter D<sub>H</sub> or D. 3) Each one calculated with the max. bore. 4) At 0.5 x T<sub>kN</sub>.

### Spare Part Spiders

Product No. Spare Part Spider	Size	Shore hardness SH A	Colour	Weight g
605 192 05	5	92	yellow	0,2
605 192 07	7	92	yellow	0,7
605 192 09	9	92	yellow	1,8
605 198 14	14	98	red	5
605 198 19	19	98	red	7
605 198 24	24	98	red	22
605 198 28	28	98	red	32
605 198 38	38	98	red	58
605 198 42	42	98	red	79
605 198 48	48	98	red	98