

## Elastic Couplings RN

**Material:** Hubs made from aluminium, plastic spider (insert) made from polyurethane, shore hardness 92° (yellow).  
Spare part plastic insert available in 92° an 98° Shore (red).  
Couplings are available undrilled or pre-drilled ex stock.

**Customized bores and feather-key grooves available at extra charge.**

Temperature range: -40°C to +90°C.

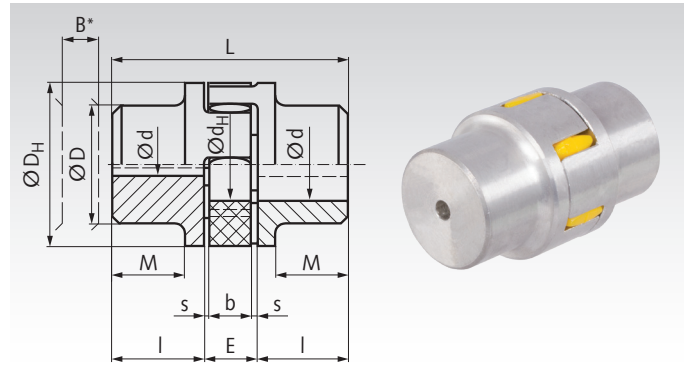

Ordering Details: e.g.: Product No. 605 197 00, Coupling RN

Product No.	Size	Torque		Bores d		max. Speed at 30m/s min <sup>-1</sup>	Torsional Angle at max. Nm	B* mm	I mm	E mm	s mm	b mm	L mm	M mm	D <sub>H</sub> mm	D mm	d <sub>H</sub> mm	Weight <sup>1)</sup> kg
		nominal Nm	max. Nm	pre-drilled mm	max. mm													
605 197 00	7	1,12	2,24	-	6,35	40000	2°	7	7	8	1	6	22	-	14	14	-	0,007
605 198 00	9	2,93	6	-	9	28000	2°	9	10	10	1	8	30	-	20	20	7	0,017
605 199 00	14	7,5	15	-	15	19000	10°	11	11	13	1,5	10	35	-	30	30	10	0,05
605 200 00	19	10	20	5,0	19	14000	5°	13	25	16	2	12	66	20	40	32	18	0,15
605 201 00	24	35	70	7,0	24	10600	5°	15	30	18	2	14	78	24	55	40	27	0,27
605 202 00	28	95	190	9,0	28	8500	5°	16	35	20	2,5	15	90	28	65	48	30	0,46
605 203 00	38	190	380	13,6	38	7100	5°	19	45	24	3	18	114	37	80	66	38	0,98
605 204 00	42	265	530	20,0	42	6000	5°	21	50	26	3	20	126	40	95	75	46	1,15
605 205 00	48	310	620	20,0	48	5600	5°	22	56	28	3,5	21	140	45	105	85	51	1,95

\* B is the average dimension by which, e.g., a driven or driving machine has to be moved in order to demount one of the coupled units in radial direction.

<sup>1)</sup> Weights refer to max. customized bore without keyways.

Matches coupling Product No.	Size	Product No. Spare Part Spider 92° Shore, yellow	Torque		Product No. Optional Spider 98° Shore, red	Torque		Weight g
			nominal Nm	max. Nm		Nominal Nm	max. Nm	
605 197 00	7	605 192 07**	1,12	2,24	—	—	—	0,7
605 198 00	9	605 192 09**	2,93	5,86	—	—	—	1,8
605 199 00	14	605 092 14	7,5	15	605 098 14	12,5	25	5
605 200 00	19	605 092 19	10	20	605 098 19	17	34	7
605 201 00	24	605 092 24	35	70	605 098 24	60	120	22
605 202 00	28	605 092 28	95	190	605 098 28	160	320	32
605 203 00	38	605 092 38	190	380	605 098 38	325	650	58
605 204 00	42	605 092 42	265	530	605 098 42	450	900	70
605 205 00	48	605 092 48	310	620	605 098 48	525	1050	98

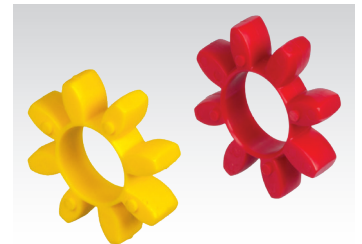

*Spare part spiders page 372*

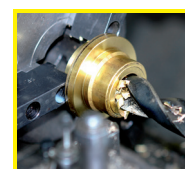

**Reworking within  
24h-service possible.  
Custom made parts  
on request.**