

Curved-Tooth Gear Couplings BOZ, Polyamide 6.6

Tolerance of the bore + 0.05/-0.10 mm with feather keyway according to DIN 6885/1 ±0.08 mm.

Grub Screws, Stainless steel V4A.

Largest axial displacement = max. ± 1 mm.

Largest angular displacement = max. ± 1° per hub part.

Largest radial displacement at 1500 min⁻¹.

Product No. 607 000 00 to 607 200 00 = max. 0.3 mm.

Product No. 607 400 00 = max. 0.35 mm.

The permissible displacement values are dependent on power and speed.

Max. speed: 6,000 min⁻¹.

All 3 parts have to be ordered seperately.

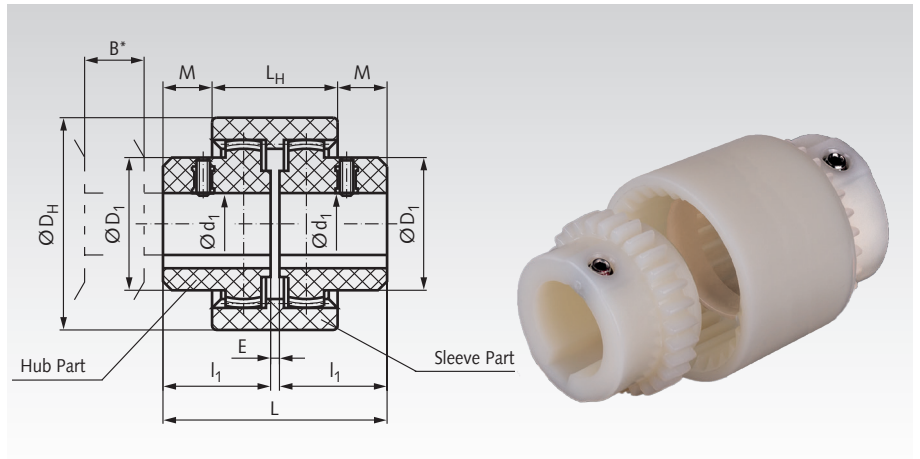

Ordering Details: e.g.:

1 Item Coupling BOZ 5 Nm Bore $d_1 = 8$, $d_2 = 10$ mm:

1 Item Product No. 607 000 00, Sleeve Part; 1 Item Product No. 607 008 00, Hub Part d_1 ; 1 Item Product No. 607 010 00, Hub Part d_2

Product No. Hub	Size	d_1 mm	Product No. Sleeve	Torque normal Nm	Torque peak Nm	D_1 mm	D_H mm	B^* mm	L_1 mm	E mm	L mm	L_H mm	M mm	Weight Hub g	Weight Sleeve g
607 006 00	14	6	607 000 00	5	10	22	40	15	23	4	50	37	6,5	13,5	27
607 007 00	14	7	607 000 00	5	10	22	40	15	23	4	50	37	6,5	13,5	27
607 008 00	14	8	607 000 00	5	10	22	40	15	23	4	50	37	6,5	13,5	27
607 009 00	14	9	607 000 00	5	10	22	40	15	23	4	50	37	6,5	13,5	27
607 010 00	14	10	607 000 00	5	10	23	40	15	23	4	50	37	6,5	13,5	27
607 011 00	14	11	607 000 00	5	10	23	40	15	23	4	50	37	6,5	13,5	27
607 012 00	14	12	607 000 00	5	10	26	40	15	23	4	50	37	6,5	13,5	27
607 014 00	14	14	607 000 00	5	10	26	40	15	23	4	50	37	6,5	13,5	27
607 212 00	19	12	607 200 00	8	16	27	47	16	25	4	54	37	8,5	15,5	34
607 214 00	19	14	607 200 00	8	16	27	47	16	25	4	54	37	8,5	15,5	34
607 216 00	19	16	607 200 00	8	16	30	47	16	25	4	54	37	8,5	15,5	34
607 219 00	19	19	607 200 00	8	16	32	47	16	25	4	54	37	8,5	15,5	34
607 410 00	24	10	607 400 00	12	24	26	53	17	26	4	56	41	7,5	25	40
607 411 00	24	11	607 400 00	12	24	26	53	17	26	4	56	41	7,5	25	40
607 412 00	24	12	607 400 00	12	24	26	53	17	26	4	56	41	7,5	25	40
607 414 00	24	14	607 400 00	12	24	32	53	17	26	4	56	41	7,5	25	40
607 415 00	24	15	607 400 00	12	24	32	53	17	26	4	56	41	7,5	25	40
607 416 00	24	16	607 400 00	12	24	32	53	17	26	4	56	41	7,5	25	40
607 418 00	24	18	607 400 00	12	24	36	53	17	26	4	56	41	7,5	25	40
607 419 00	24	19	607 400 00	12	24	36	53	17	26	4	56	41	7,5	25	40
607 420 00	24	20	607 400 00	12	24	36	53	17	26	4	56	41	7,5	25	40
607 424 00	24	24	607 400 00	12	24	38,5	53	17	26	4	56	41	7,5	25	40

* B is the minimum dimension by which a machine part has to be moved in order to demount one of the coupled units in vertical direction.

General

The couplings BOZ are double-cardanic couplings to compensate radial and angular misalignment.

All parts of the couplings are made from plastic (polyamide) and consist of one sleeve part with 2 internal toothings and 2 hub parts d_1 and d_2 with external toothing.

This means large wear resistance and excellent resistance to oils, fats, grease, fuels, alcohols, esters, ketones, and grachatic hydrocarbons. But concentrated mineral acids, formic acid, kresol, glycol and benzyl alcohol can - especially at higher temperatures - dissolve polyamide 6.6. The plastics are resistant to condensation and splash water. Operating temperature -25°C to +100°C.

When running the coupling in, the outer layer of the plastic teeth is worn away. The resulting flocculent abrasion is not to be interpreted as wear. Simple mounting - no maintenance - low weight - long service life.

Mounting

Align shafts, put feather keys into the keyways, push hub and sleeve part onto the shaft. The set screws can be entered. Now the hub part is pushed that far into the sleeve part, that a gap of 4mm remains between the shaft ends. Then the set screws have to be tightened firmly.

Selection Tool
on the Internet at www.maedler.de
in the section **MÄDLER®-Tools**