

Locking Assemblies SSG

Material: Steel.

- For fixing a hub (e.g. drive wheel, rotor or similar) on a shaft.
- For low to medium torques.
- Also suitable for small hub diameters.
- Self-centering.
- Self-locking.
- Axial movement during mounting.

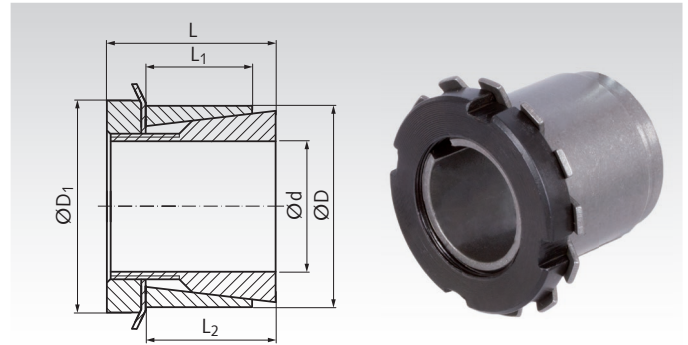

Ordering Details: e.g.: Product No. 615 200 14, Locking Assembly SSG, 14 mm

Product No..	d mm	D mm	L mm	L ₁ mm	L ₂ mm	D ₁ mm	T Nm	F _{ax} kN	P _w N/mm ²	P _N N/mm ²	Nut 8.8 Thread	T _A Nm	Weight kg
615 200 14	14	25	30	20	23	32	61	9	81	43	M20x1	95	0,08
615 200 15	15	25	30	20	23	32	72	9	82	46	M20x1	95	0,08
615 200 16	16	25	30	20	23	32	73	9	75	45	M20x1	95	0,07
615 200 17	17	25	32	20	24	32	82	9	72	46	M20x1	95	0,09
615 200 18	18	30	32	20	24	38	98	10	78	44	M25x1,5	160	0,12
615 200 19	19	30	32	20	24	38	102	11	73	44	M25x1,5	160	0,12
615 200 20	20	30	32	20	24	38	110	11	69	44	M25x1,5	160	0,11
615 200 22	22	35	36	25	28	45	165	13	71	45	M30x1,5	220	0,18
615 200 24	24	35	36	25	28	45	178	14	65	45	M30x1,5	220	0,16
615 200 25	25	35	36	25	28	45	178	14	58	43	M30x1,5	220	0,19
615 200 28	28	40	42	30	33	52	248	17	54	40	M35x1,5	340	0,24
615 200 30	30	40	42	30	33	52	273	17	51	40	M35x1,5	340	0,24
615 200 32	32	45	44	30	34	58	347	21	59	45	M40x1,5	480	0,32
615 200 35	35	45	44	30	34	58	406	22	57	47	M40x1,5	480	0,32
615 200 38	38	50	45	30	34	65	510	25	62	46	M45x1,5	680	0,35
615 200 40	40	50	45	30	34	65	520	27	54	44	M45x1,5	680	0,33
615 200 42	42	55	46	30	34	70	650	29	68	52	M50x1,5	870	0,43
615 200 45	45	55	46	30	34	70	660	31	57	48	M50x1,5	870	0,40
615 200 48	48	60	46	30	34	75	810	34	58	48	M55x2	970	0,45
615 200 50	50	60	46	30	34	75	850	34	58	49	M55x2	970	0,40
615 200 55	55	65	46	30	34	80	1020	37	59	50	M60x2	1100	0,44
615 200 60	60	70	52	30	35	85	1290	43	62	52	M65x2	1300	0,55

T = transmittable torque at F_{ax} = 0.

F_{ax} = transmittable axial force at T = 0.

P_w = surface pressure onto the shaft.

P_N = surface pressure onto the hub.

T_A = fastening torque of slotted nut.

Fit

Shaft h8, Hub H8.
Surface roughness R_z max. 12.5 µm.

Mounting

Slightly oil the locking assembly before mounting, do not use molybdenum disulphide or grease. Tighten the slotted nut and bend the lock washer.

Demounting

Re-bend the lock washer. Remove the nut. Then, due to the cone angle, the locking assembly is usually released. If not, use a wheel puller or use carefully a rubber hammer to loosen the wheel from the clamping rings.