

## Clamping Bushes MSD-N

**Material:** Stainless steel 1.4568 (17/7 PH).

The MSD-N clamping bush is identical with the MSD bush, but is made from stainless steel. It has been used in many industries for years, as, e.g., the food, medical, automotive, chemical, printing and process engineering industries.

Concentricity 0.03 - 0.06 mm.

**Tolerance:** Shaft h9 (Ø 15 mm only h8), Hub H7.

**Temperature range:** -30 °C to 85 °C.

$P_W \approx 90\text{N/mm}^2$       $P_N \approx 70\text{N/mm}^2$

Ordering Details: e.g.: Product No. 615 993 15, Clamping Bush MSD-N, 15 mm

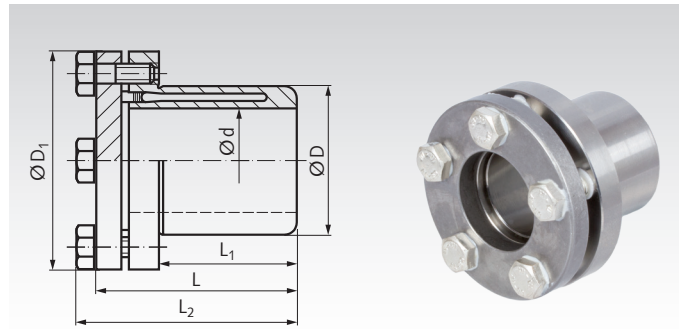

Product No.	Dimensions						at $T_A$ transmittable Torque Force		Screws DIN 933, A4			Moment of Inertia J $\text{kgm}^2 \cdot 10^{-3}$	Weight kg
	d mm	D mm	$D_1$ mm	L mm	$L_1$ mm	$L_2$ mm	T Nm	$F_{ax}$ kN	Amount	Size	$T_A$ Nm		
615 993 15	15	23	38	30	17	34	45	6	4	M 5	4,5	0,018	0,10
615 993 20	20	28	45	37	22	41	100	10	5	M 5	4,5	0,046	0,16
615 993 25	25	34	49	43	27	46	210	16,8	7	M 5	4,5	0,071	0,19
615 993 30	30	41	57	47	32	51	350	23,3	7	M 5	4,5	0,142	0,29
615 993 40	40	53	70	63	43	67	750	37,5	9	M 5	4,5	0,441	0,55
615 993 50	50	65	83	76	53	80	1550	62	9	M 6	7,8	1,045	0,86

T = transmittable torque at axial force of 0, if the screws are fastened with  $T_A$ .

$F_{ax}$  = transmittable axial force at torque of 0, if the screws are fastened with  $T_A$ .

$T_A$  = required fastening torque for the screws.

The dimensions refer to bushes before assembly.

## Miniature Clamping Bushes MSM and MSM-N

**Material:** Version MSM: Mild steel.

Version MSM-N: Stainless steel 1.4305 (AISI 303).



Concentricity: about 0.02 mm.

Tolerance: Shaft k6-h10, Hub H8.

$P_W \approx 90\text{N/mm}^2$       $P_N \approx 70\text{N/mm}^2$

Ordering Details: e.g.: Product No. 615 206 00, Miniature Clamping Bush MSM, 6 mm

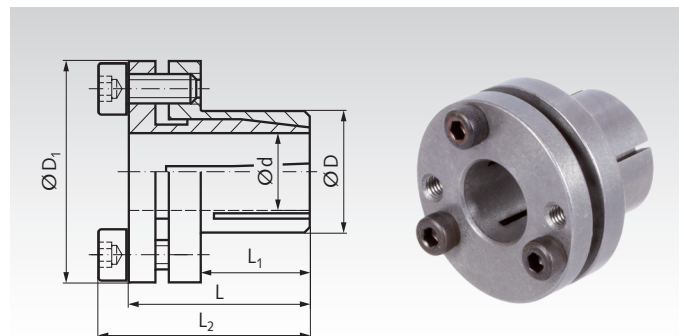

Product No.	Dimensions						at $T_A$ transmittable Torque Force		Screws DIN 912, 12.9			Moment of Inertia J $\text{kgm}^2 \cdot 10^{-3}$	Weight kg
	d mm	D mm	$D_1$ mm	L mm	$L_1$ mm	$L_2$ mm	T Nm	$F_{ax}$ kN	Amount	Size	$T_A$ Nm		
615 206 00	6	14	25	19	10	22	7	2,5	2	M3 x 8	2	2,1	0,03
615 208 00	8	15	27	21,5	12	25,5	20	5	2	M4 x 8	4	3,3	0,04
615 209 00	9	16	28	24	14	28	28	6,5	2	M4 x 8	4	4,4	0,05
615 210 00	10	16	28	24	14	28	34	6,5	2	M4 x 8	4	4,3	0,05
615 211 00	11	18	30	25,5	14	29,5	36	6,5	2	M4 x 10	4	6,2	0,06
615 212 00	12	18	30	25,5	14	29,5	40	6,5	2	M4 x 10	4	6,1	0,06
615 214 00	14	22	35	27,5	15	31,5	66	9,5	3	M4 x 10	4	13,2	0,08

MSM-N Stainless

Screws DIN 912, A4

615 992 06	6	14	25	19	10	22	5	1,7	3	M3 x 8	1,2	2,1	0,03
615 992 08	8	15	27	21,5	12	25,5	17	4,4	3	M4 x 8	2,7	3,3	0,04
615 992 10	10	16	28	24	14	28	23	4,4	3	M4 x 8	2,7	4,4	0,05
615 992 12	12	18	30	25,5	14	29,5	27	4,4	3	M4 x 10	2,7	6,1	0,06
615 992 14	14	22	35	27,5	15	31,5	48	6,5	4	M4 x 12	2,7	13,2	0,08

T = transmittable torque at axial force of 0, if the screws are fastened with  $T_A$ .

$F_{ax}$  = transmittable axial force at torque of 0, if the screws are fastened with  $T_A$ .

$T_A$  = required fastening torque for the screws.

The dimensions refer to bushes before assembly.

### Mounting

The bush is mounted quickly. Just place the bush inside the hub and push both onto the shaft. Fasten with a torque wrench.

### Demounting

Remove tensioning screws. Put screws in forcing thread and fasten them until the bush is pressed off.