

Locking Assemblies COM-C

Material: Steel.

- For fixing a hub (e.g. drive wheel, rotor or similar) on a shaft.
- For medium to high torques.
- Self-centering.
- No axial offset.

Concentricity: 0.02 to 0.04 mm.

Ordering Details: e.g.: Product No. 615 571 18, Locking Assembly COM-C, 18 mm

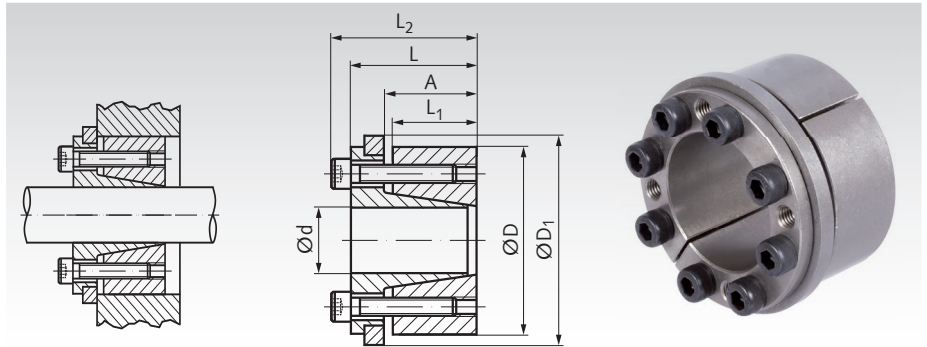

Product No.	d mm	D mm	L ₁ mm	A mm	L mm	L ₂ mm	D ₁ mm	at T _A transmittable		Surface Pressure		Screws DIN 912 12.9 Number x size	T _A Nm	Weight kg
								T Nm	F _{ax} kN	Shaft P _w N/mm ²	Hub P _N N/mm ²			
615 571 18	18	47	26	30	39	45	53	300	32	155	70	6 x M6 x 22	17	0,40
615 571 19	19	47	26	30	39	45	53	320	32	165	70	6 x M6 x 22	17	0,39
615 571 20	20	47	26	30	39	45	53	340	34	175	75	6 x M6 x 22	17	0,38
615 571 22	22	47	26	30	39	45	53	370	34	160	75	6 x M6 x 22	17	0,37
615 571 24	24	50	26	30	39	45	56	400	34	145	70	6 x M6 x 22	17	0,45
615 571 25	25	50	26	30	39	45	56	420	34	140	70	6 x M6 x 22	17	0,44
615 571 28	28	55	26	30	39	45	61	470	34	125	65	6 x M6 x 22	17	0,50
615 571 30	30	55	26	30	39	45	61	510	34	115	65	6 x M6 x 22	17	0,45
615 571 32	32	60	26	30	39	45	66	720	45	145	80	8 x M6 x 22	17	0,59
615 571 35	35	60	26	30	39	45	66	790	45	135	80	8 x M6 x 22	17	0,53
615 571 38	38	65	26	30	39	45	71	860	45	125	70	8 x M6 x 22	17	0,62
615 571 40	40	65	26	30	39	45	71	900	45	120	70	8 x M6 x 22	17	0,60
615 571 42	42	75	30	35	47	55	81	1320	63	135	75	6 x M8 x 30	41	1,05
615 571 45	45	75	30	35	47	55	81	1410	63	125	75	6 x M8 x 30	41	0,98
615 571 48	48	80	30	35	47	55	86	2010	84	120	70	6 x M8 x 30	41	1,30
615 571 50	50	80	30	35	47	55	86	2100	84	110	70	6 x M8 x 30	41	1,00
615 571 55	55	85	30	35	47	55	91	2310	84	135	90	8 x M8 x 30	41	1,10
615 571 60	60	90	30	35	47	55	96	2520	84	124	85	8 x M8 x 30	41	1,20
615 571 65	65	95	30	35	47	55	102	2730	84	115	80	8 x M8 x 30	41	1,25
615 571 70	70	110	40	45	61	71	117	4670	133	125	80	8 x M10 x 35	83	2,36
615 571 75	75	115	40	45	61	71	122	5000	133	120	80	8 x M10 x 35	83	2,65
615 571 80	80	120	40	45	61	71	127	5330	133	110	75	8 x M10 x 35	83	2,70
615 571 85	85	125	40	45	61	71	132	7080	167	130	90	10 x M10 x 35	83	2,95
615 571 90	90	130	40	45	61	71	137	7500	167	125	85	10 x M10 x 35	83	3,0
615 571 95	95	135	40	45	61	71	142	7920	167	115	85	10 x M10 x 35	83	3,0
615 572 00	100	145	46	52	70	82	153	9710	194	115	80	8 x M12 x 40	145	5,5

More sizes up to d=180mm for 34,600Nm are available.

Price and delivery time on request.

T = transmittable torque at F_{ax} = 0.

F_{ax} = transmittable axial force at T = 0.

P_w = surface pressure onto the shaft.

P_N = surface pressure onto the hub.

T_A = fastening torque of the screws.

Fit

Shaft h8, Hub H8.
Surface roughness hub/shaft R_z
max. 12.5 µm.

Mounting

Slightly oil the locking assembly before mounting, do not use MoS2 or grease.
Tighten the screws evenly and crosswise in several steps to the set torque.

Demounting

Remove all tensioning screws and screw them into the unused forcing threads of the front flange evenly and crosswise in several steps, until the flange is released.