

## Locking Assemblies COM-B

Material: Steel.

- For fixing a hub (e.g. timing belt pulley or similar) on a shaft.
- For medium torques.
- Also suitable for small hub diameters.
- Self-centering.
- Self-locking.
- No axial movement during mounting.

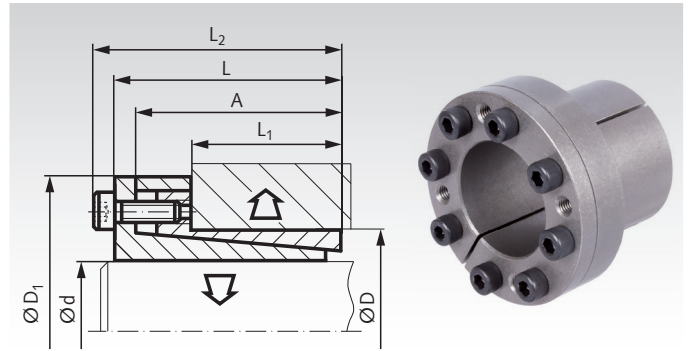

Ordering Details: e.g.: Product No. 615 606 00, Locking Assembly COM-B, 6 mm

Product No.	d mm	D mm	L mm	A mm	L <sub>1</sub> mm	L <sub>2</sub> mm	D <sub>1</sub> mm	T Nm	F <sub>ax</sub> kN	P <sub>w</sub> N/mm <sup>2</sup>	P <sub>N</sub> N/mm <sup>2</sup>	Screw 12.9 Number x Size	T <sub>A</sub> Nm	Weight kg
615 606 00	6	14	21	18,5	10	24	25	12	4	185	80	3 x M3	2	0,05
615 606 35	6,35	14	21	18,5	10	24	25	12	4	185	80	3 x M3	2	0,05
615 607 00	7	15	25	22	12	29	27	24	7	223	111	3 x M4	5	0,07
615 608 00	8	15	25	22	12	29	27	29	7	207	111	3 x M4	5	0,07
615 609 00	9	16	26	23	14	30	28	42	10	197	110	4 x M4	5	0,07
615 609 53	9,53	16	26	23	14	30	28	42	10	197	110	4 x M4	5	0,07
615 610 00	10	16	26	23	14	30	28	48	10	179	112	4 x M4	5	0,07
615 611 00	11	18	26	23	14	30	32	51	10	165	102	4 x M4	5	0,07
615 612 00	12	18	26	23	14	30	32	55	10	152	100	4 x M4	5	0,08
615 612 70	12,7	18	26	23	14	30	32	55	10	152	100	4 x M4	5	0,08
615 614 00	14	23	26	23	14	30	38	68	10	130	80	4 x M4	5	0,11
615 615 00	15	24	36	29	16	42	45	133	18	194	121	3 x M6	17	0,22
615 616 00	16	24	36	29	16	42	45	140	18	180	118	3 x M6	17	0,22
615 617 00	17	26	38	31	18	44	47	180	22	190	125	4 x M6	17	0,25
615 618 00	18	26	38	31	18	44	47	200	22	180	125	4 x M6	17	0,23
615 619 00	19	27	38	31	18	44	49	210	22	172	121	4 x M6	17	0,25
615 620 00	20	28	38	31	18	44	50	220	22	160	115	4 x M6	17	0,26
615 622 00	22	32	45	38	25	51	54	250	22	113	78	4 x M6	17	0,35
615 624 00	24	34	45	38	25	51	56	270	22	106	76	4 x M6	17	0,36
615 625 00	25	34	45	38	25	51	56	280	22	101	76	4 x M6	17	0,34
615 625 40	25,4	34	45	38	25	51	56	280	22	101	76	4 x M6	17	0,34
615 628 00	28	39	45	38	25	51	61	450	32	130	93	6 x M6	17	0,42
615 630 00	30	41	45	38	25	51	62	500	32	133	95	6 x M6	17	0,43
615 632 00	32	43	45	38	25	51	65	540	35	115	86	6 x M6	17	0,49
615 635 00	35	47	52	45	32	58	69	800	44	106	81	8 x M6	17	0,55
615 638 00	38	50	52	45	32	58	72	900	45	105	79	8 x M6	17	0,62
615 640 00	40	53	52	45	32	58	75	900	45	92	68	8 x M6	17	0,64
615 642 00	42	55	52	45	32	58	78	1000	47	90	70	8 x M6	17	0,85
615 645 00	45	59	70	62	45	78	86	1800	80	105	81	8 x M8	41	1,05
615 648 00	48	62	70	62	45	78	87	1950	81	102	78	8 x M8	41	1,13
615 650 00	50	65	70	62	45	78	92	2020	81	96	72	8 x M8	41	1,26
615 655 00	55	71	80	72	55	88	98	2730	95	89	68	9 x M8	41	1,53
615 660 00	60	77	80	72	55	88	104	2870	98	76	61	9 x M8	41	1,66
615 665 00	65	84	80	72	55	88	111	3190	99	73	57	9 x M8	41	1,90
615 670 00	70	90	96	86	65	106	119	5150	147	88	69	9 x M10	83	3,0
615 675 00	75	95	96	86	65	106	126	5710	153	82	66	9 x M10	83	3,1
615 680 00	80	100	96	86	65	106	131	8260	196	103	82	12 x M10	83	3,3
615 685 00	85	106	96	86	65	106	137	8670	204	97	77	12 x M10	83	3,6
615 690 00	90	112	96	86	65	106	144	8800	206	88	74	12 x M10	83	4,0
615 695 00	95	120	96	86	65	106	149	11300	237	103	82	14 x M10	83	4,7
615 700 00	100	125	96	86	65	106	154	14300	285	114	90	18 x M10	83	5,2

More sizes up to d=130mm for 24,800Nm are available.

Price and delivery time on request.

- T = transmittable torque at  $F_{ax} = 0$ .  
 $F_{ax}$  = transmittable axial force at  $T = 0$ .  
 $P_w$  = surface pressure onto the shaft.  
 $P_N$  = surface pressure onto the hub.  
 $T_A$  = fastening torque of the screws.

### Fit

Shaft h8, Hub H8.  
 Surface roughness  $R_z$  max. 12.5  $\mu\text{m}$ .

### Mounting

Slightly oil the locking assembly before mounting, do not use molybdenum disulphide or grease. Tighten the screws evenly and crosswise in several steps.

### Demounting

Remove all tensioning screws and screw them into the (usually unused) forcing thread of the front flange, until the flange is released.