

Locking Assemblies BAR, QPQ-Coated

Material: Steel.

- For fixing a hub on a shaft.
- **QPQ coated:** High corrosion resistance, improved fatigue strength, primarily food safe (further information see below).
- For medium torques.
- Self-centering.
- Slight axial offset possible during assembly.

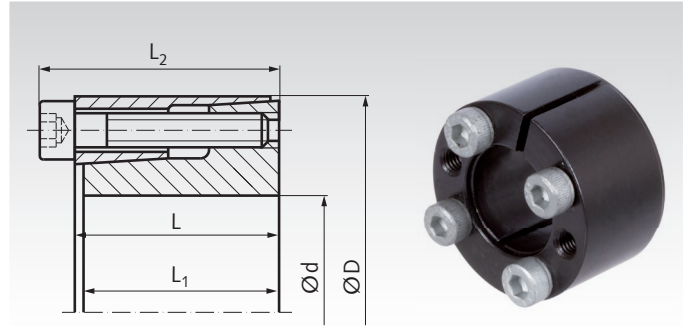

Ordering Details: e.g.: Product No. 615 705 00, Locking Assembly BAR QPQ, 5 mm Bore

Product No.	d mm	D mm	L mm	L ₁ mm	L ₂ mm	at T _A transmittable		Surface Pressure		Tensioning Screw 12.9*			Weight kg
						T Nm	F _{ax} kN	at Shaft P _w N/mm ²	at Hub P _N N/mm ²	Size DIN 912	T _A Nm	Number	
615 705 00	5	16	11	10,5	13,5	6	2	150	55	M2,5 x 10	1,2	3	0,012
615 706 00	6	16	11	10,5	13,5	9	3	184	69	M2,5 x 10	1,2	3	0,012
615 706 35	6,35	16	11	10,5	13,5	10	3	180	72	M2,5 x 10	1,2	3	0,012
615 708 00	8	18	11	10,5	13,5	12	3	141	62	M2,5 x 10	1,2	3	0,015
615 709 00	9	20	13	12,5	15,5	17	4	132	60	M2,5 x 12	1,2	4	0,020
615 710 00	10	20	13	12,5	15,5	19	4	120	60	M2,5 x 12	1,2	4	0,019
615 711 00	11	22	13	12,5	15,5	21	4	108	54	M2,5 x 12	1,2	4	0,024
615 712 00	12	22	13	12,5	15,5	24	4	102	55	M2,5 x 12	1,2	4	0,022
615 714 00	14	26	17	16,5	20	40	6	94	50	M3 x 16	2,1	4	0,039
615 715 00	15	28	17	16,5	20	44	6	93	50	M3 x 16	2,1	4	0,044
615 716 00	16	32	17	16,5	21	86	10	158	79	M4 x 16	4,9	4	0,067
615 717 00	17	35	21	20,5	25	88	10	116	56	M4 x 20	4,9	4	0,090
615 718 00	18	35	21	20,5	25	94	11	110	57	M4 x 20	4,9	4	0,087
615 719 00	19	35	21	20,5	25	99	11	104	56	M4 x 20	4,9	4	0,080
615 720 00	20	38	21	20,5	26	179	17	169	89	M5 x 20	10	4	0,10
615 722 00	22	40	21	20,5	26	187	18	146	90	M5 x 20	10	4	0,11
615 725 00	25	47	26	25	32	300	24	147	78	M6 x 25	17	4	0,19
615 730 00	30	55	26	25	32	510	32	174	95	M6 x 25	17	6	0,27
615 735 00	35	60	31	30	37	820	47	172	100	M6 x 30	17	8	0,36
615 738 00	38	65	31	30	37	880	47	157	92	M6 x 30	17	8	0,43
615 740 00	40	65	31	30	37	1000	50	171	99	M6 x 30	17	8	0,40
615 750 00	50	80	36	35	44	2150	89	190	118	M8 x 35	40	8	0,70

* Screws with special coating.

T = transmittable torque at F_{ax} = 0.

F_{ax} = transmittable axial force at T = 0.

P_w = surface pressure onto the shaft.

P_N = surface pressure onto the hub.

T_A = fastening torque of the screws.

What is QPQ Nitro Carburising?

QPQ means:

- Q** = Quench (nitrocarburising followed by oxidising cooling process).
- P** = Polish (mechanical polishing up to desired surface finish before nitrocarburising).
- Q** = Quench (Oxidising to increase the corrosion resistance).

Salt-bath nitro carburising using the TENIFER method is, in many cases, a good alternative to other surface layer treatments as case hardening or hard plating. The principle task of the QPQ surface refinement is to protect machine components of all industries against wear and corrosion, but it also meets other functional requirements as, e.g., improving the endurance strength.

Mounting und Hub Calculation

Notes regarding fit, surface structure, mounting, demounting and hub calculation see page 312.

QPQ Surface Properties

Very good corrosion resistance, better than hard chrome or chem. nickel. Corrosion resistance in the salt spray test SS CASS in accordance with DIN 50021.

Layer thickness of 10 - 25 µm possible. For medium operational demands we recommend a layer thickness of approx. 15 µm at a 90 minute treatment.

Only very small changes in dimensions (only 5 µm), as the surface modification is achieved through diffusion and not application.

Surface hardness same as clamping set material ≥ 350 HV.

Improved wear resistance, no fretting corrosion, no cold shut.

Increased endurance strength, sometimes up to 100% higher.

Is completely safe to use with food as long as there is no contact with any acidic substances with a pH-value of ≤ 4.