

## Precision Worm Gear Sets - Right Hand (Worm Gears and Worm Shafts)

Pressure angle: 20°.

**Material:** Worm gears with cast iron hub made from grey cast iron GG20 and toothed ring made from special worm-gear bronze (G-CuSn12Ni).

Worm shafts made from Steel C45 hardened. Shaft ends not tempered. Tooth flanks ground.

### Worm Gears, Centre Distance in Casing $a = 125 \text{ mm} \pm 0.03$

Ordering Details: e.g.: Product No. 332 239 01, Pr.-Worm Gear,  $a = 125$ ,  $i = 39$

Product No.	Trans- mission	Module	Number of teeth	$d_A$ mm	$d_0$ mm	$D_1$ mm	$b$ mm	$Md_2$ at 1500min <sup>-1</sup> Nm	$\eta^*$	Weight kg
332 239 01	39	5	39	215	200	136	38	1060	0,78	10,1
332 262 01	62	3,15	62	206,5	197	145	34	1160	0,68	8,5
332 282 01	82	2,5	82	215	207,5	160	34	860	0,66	7,97
332 307 01	107	2	107	221	214,5	168	34	580	0,62	7,9

\* The figures stated for the efficiency are only reference values, since - besides the lead angle - mounting, lubrication, speed and assembly also have an influence on the efficiency.

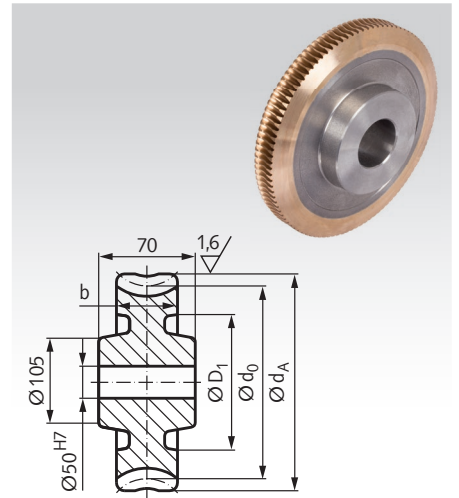

### Worm Shafts, Centre Distance in Casing $a = 125 \text{ mm} \pm 0.03$

Ordering Details: e.g.: Product No. 332 239 02, Pr.-Worm Shaft,  $a = 125$ ,  $i = 39$

Product No.	Trans- mission	Module	Number of Threads	$d_A$ mm	$d$ mm	ND mm	G mm	e mm	$\eta^*$	Weight kg
332 239 02	39	5	1	60	50	50,5	82	135	0,78	6,06
332 262 02	62	3,15	1	59,3	53	50,5	64	105	0,68	6,35
332 282 02	82	2,5	1	47,5	42,5	45,5	58	105	0,66	4,9
332 307 02	107	2	1	39,5	35,5	40,5	52	105	0,62	3,75

\* The figures stated for the efficiency are only reference values, since - besides the lead angle - mounting, lubrication, speed and assembly also have an influence on the efficiency.

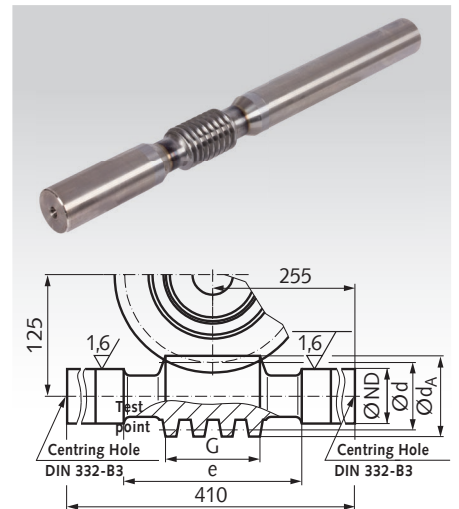

### Self-locking capacity

The self-locking capacity is influenced by the lead angle, the surface structure of the flanks, the sliding speed, the lubricant and the heating.

For worm gears with centre distance  $a=100\text{mm}$  and  $125\text{mm}$ :

ratio 39:1 not self-locking.

From ratio 62:1 Static self-locking.

Shocks or vibration can override the self-locking capacity. Apart from that, various factors in connection with lubrication, gliding speed and load can create such favourable operating conditions that the self-locking capacity is negatively influenced.

For this reason we cannot grant any guarantee regarding the self-locking capacity.

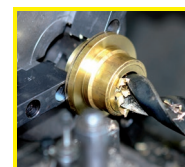

**Reworking within  
24h-service possible.  
Custom made parts  
on request.**