

Bevel Gears Made from Steel, Spiral Tooth System, Ratio 1:1

Material up to module 1.5: 42CrMo4, teeth induction hardened.

Material from module 2.0: 16MnCr5, teeth case hardened.

Hubs and bores soft.

Products marked with *** are not hardened.

With cyclo-palloid spiral tooth system. Tooth quality 8 modelled on DIN 3967.

Sold in pairs only.

Ordering Details: e.g.:

Product No. 385 308 00 = 1 Pair of Bevel Gears Ratio 1:1

Mod. 0.6 16/16 Teeth

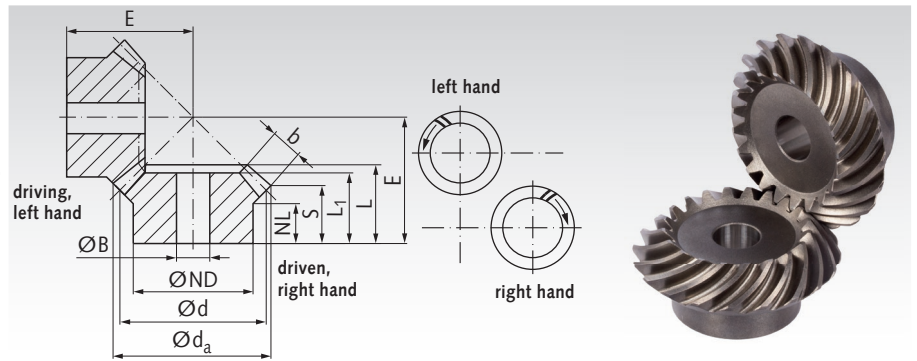

Ratio 1:1

Product No.	Module	Number of teeth	d _a mm	d mm	ND mm	NL mm	L ₁ mm	L mm	S ¹⁾ mm	b mm	BH7 mm	E mm	Torque* Nm	Weight g/Pair
385 308 00	0,6	16	15,8	15,5	10	4,5	9	10,0	7,7	3,3	5	15	0,64	12
385 310 00	0,6	20	16,9	16,5	12	6,5	11	12,0	9,2	4	5	17	1,27	19
385 316 00	0,6	25	23,3	22,5	19	7,2	12	13,4	9,2	6	6	20	2,1	50
385 320 00	0,6	30	27,8	27	22	7	13	14,9	9,9	7	8	23	3,0	75
385 322 00	0,6	35	32,3	31,5	25	7,2	15	16,3	10,6	8	8	26	3,5	116
385 508 00	1	16	25,4	24	17	7,5	13,5	15,95	11,7	6	6	23	2,5	55
385 511 00	1	20	31,4	30	25	8,4	15	17,3	11,7	8	8	26	6,3	112
385 516 00	1	25	38,9	37,5	25	8	16	19,0	11,9	10	10	30	10,0	155
385 520 00	1	30	46,4	45	30	8	19	21,7	13,2	12	10	35	14,3	278
385 611 00	1,3	20	41,8	40	30	7,3	19	20,7	12,9	11	10	32	14,8	222
385 616 00	1,3	25	51,8	50	30	8	19	21,8	11,9	14	10	36	18,5	326
385 620 00	1,3	30	61,8	60	35	8	21	24,2	12,9	16	12	42	31,5	530
385 709 00	1,5	18	41,7	39,6	30	8	17	20,3	13,2	10	10	32	15,9	209
385 715 00	1,5	24	54,9	52,8	35	8	20	22,6	12,7	14	10	38	21,2	408
385 719 00	1,5	28	63,7	61,6	40	8	20	23,2	13,3	14	12	43	34,5	576
386 012 00**	2,2881	21	71,5	70	45	15	28	32,22	22,5	15	16	55	70	973
386 016 00**	2	25	80,3	78	45	15	29	32,3	22,4	14	16	60	73	1200
381 019 00***	2	26	82,0	80	55	20	35	37,73	26,8	16	16	65	42	1581
386 112 00**	2,5	19	90,0	88	56	18	34	36,91	23,5	20	20	65	185	1700
386 117 00**	2,5	24	98,0	96	54	16	32	37,2	24,5	19	20	70	188	2000
386 412 00**	3	21	103,0	100	68	17	36	43,4	27,7	23	25	75	240	2600
386 417 00**	3	24	115,0	112	64	18	34	41,7	26,7	22	25	80	260	2800
386 517 00**	3,5	24	131,0	128	72	20	38	46,15	29,5	25	30	90	396	4200
381 519 00***	3,5	26	144,0	140	85	30	57	62,3	43,0	28	30	110	238	7300

¹⁾ Theoretical dimensions, from module 2, tips of teeth levelled.

* Basis for calculations see page 316.

** Gears with ground hub contact surfaces and bores.

*** Not hardened.

Description of spiral toothed bevel gears

Distinctive features of bevel gears with spiral tooth system (spiral bevel gears):

Klingenberg Cyclo-Palloid Tooth System: These gears are produced using the continuous generating method with a two-part cutter head. The tooth curvature follows the path of an extended epicycloid.

Klingenberg Palloid Tooth System: These gears are produced using the continuous indexing method with a cone shaped gear hob. The tooth curvature follows the path of an extended involute.

Gleason-Circarc Gearing: These gears are produced using the continuous indexing method with a disk-shaped cutting head. The tooth curvature follows the path of a circular arc.

Cyclo-Palloid-, Palloid- and Gleason Tooth Systems are not interchangeable.

The spiral tooth system offers very quiet running as there are always several teeth in mesh. Without load, the contact profile zone should be in the middle of the tooth, lengthwise. Under load the contact profile zone evenly expands towards the inside and outside diameter. The ground contact surfaces of the hubs and bores guarantee an exact adjustment of the assembly dimension E.

Sense of rotation:

If the transmission ratio is not 1:1, the rotational direction marked on the drawing above should be preferred (more favourable direction of the axial forces).

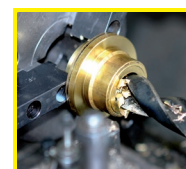

Reworking within 24h-service possible. Custom made parts on request.