

## Precision Spur Gears, Helical Tooth System, Case Hardened with Ground Teeth Flanks

Material: Steel 16MnCr5.

Tooth quality 7e25.

Helical tooth system, left hand 19° 31' 42".

Case hardened, approx. 60 HRC.

Keyways in accordance with DIN 6885/1, tolerance P9.

Teeth, bores and faces ground. Matching helical-toothed gear racks page 266.

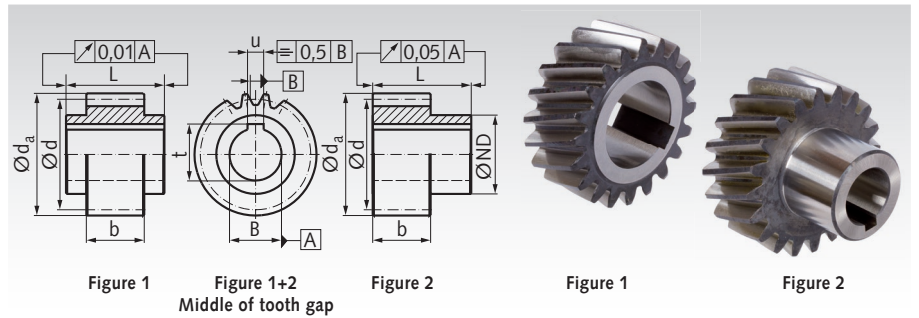

Ordering Details: e.g.: Product No. 254 015 35, Spur gear, Steel 16 MnCr5, Module 4.0, 15 Teeth, Ground

### Module 4 (Pitch 13.333mm), Tooth Width $b = 40$ mm

Product No.	Number of teeth	b mm	Figure	$d_a$ mm	d mm	$d \times \pi$ mm	BH6 mm	ND mm	L mm	u mm	t mm	perm. MT* Nm	Weight kg
254 015 35	15	40	1	71,7	63,66	200,00	35	52	50	10	38,3	670	1,4
254 018 32	18	40	2	84,4	76,39	240,00	32	55	75	10	35,3	900	1,5
254 020 35	20	40	1	92,9	84,88	266,67	35	52	50	10	38,3	975	1,9
254 021 32	21	40	2	97,1	89,13	280,00	32	55	75	10	35,3	1050	2,0
254 021 35	21	40	2	97,1	89,13	280,00	35	55	75	10	38,3	1050	1,9
254 021 40	21	40	2	97,1	89,13	280,00	40	62	75	12	43,3	1050	1,9
254 024 32	24	40	2	109,9	101,86	320,00	32	55	75	10	35,3	1150	2,6
254 024 35	24	40	2	109,9	101,86	320,00	35	55	75	10	38,3	1150	2,5
254 024 40	24	40	2	109,9	101,86	320,00	40	62	75	12	43,3	1150	2,5
254 024 55	24	40	2	109,9	101,86	320,00	55	80	80	16	59,3	1150	2,4
254 025 35	25	40	1	114,1	106,10	333,33	35	52	50	10	38,3	1200	3,1
254 025 45	25	40	1	114,1	106,10	333,33	45	65	50	14	48,8	1200	2,8

### Module 5 (Pitch 16.666mm), Tooth Width $b = 50$ mm

Product No.	Number of teeth	b mm	Figure	$d_a$ mm	d mm	$d \times \pi$ mm	BH6 mm	ND mm	L mm	u mm	t mm	perm. MT* Nm	Weight kg
255 018 45	18	50	2	105,5	95,49	300,00	45	68	85	14	48,8	1575	2,7
255 024 45	24	50	2	137,3	127,32	400,00	45	68	85	14	48,8	2085	4,9
255 024 55	24	50	2	137,3	127,32	400,00	55	80	90	16	59,3	2085	4,9

#### Note

These gears are designed to be used in combination with the helical-toothed gear racks page 266. If this gear is used to drive a mating gear instead, this mating gear must have the same lead angle and the opposite tooth direction (right hand).

*Helical Tooth  
Gear racks  
Page 266*

