

Spur Gears Made from Brass, Milled Teeth, Straight Tooth System

Material: Ms58 (2.0401).

Tooth quality 8d DIN 58405.

Pressure angle 20°.

Up to 30 teeth without hub.

From 40 teeth with one-sided hub.

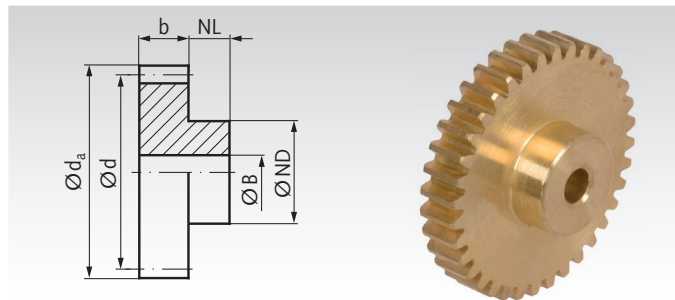

Ordering Details: e.g.: Product No. 260 010 00, Spur Gear Ms, Module 0.3, 10 Teeth

Module 0.3

Product No.	Number of teeth	b** mm	d_a mm	d mm	NL mm	ND mm	BH7 mm	perm. MT* Ncm	Weight g
260 010 00	10	5	3,6	3	-	-	1,0	0,14	0,1
260 012 00	12	5	4,2	3,6	-	-	1,5	0,18	0,2
260 014 00	14	5	4,8	4,2	-	-	2,0	0,23	0,4
260 015 00	15	5	5,1	4,5	-	-	2,0	0,25	0,5
260 016 00	16	5	5,4	4,8	-	-	2,0	0,27	0,6
260 018 00	18	5	6,0	5,4	-	-	2,0	0,36	0,8
260 020 00	20	5	6,6	6	-	-	2,0	0,40	1,0
260 022 00	22	5	7,2	6,6	-	-	2,0	0,49	1,3
260 024 00	24	5	7,8	7,2	-	-	2,0	0,60	1,4
260 025 00	25	5	8,1	7,5	-	-	2,0	0,65	1,6
260 030 00	30	5	9,6	9	-	-	2,0	1,00	2,3
260 040 00	40	2	12,6	12	3	10	3,0	1,85	3,5
260 050 00	50	2	15,6	15	5	10	3,0	3,00	5,7
260 060 00	60	2	18,6	18	5	10	3,0	4,50	6,9
260 080 00	80	2	24,6	24	5	15	3,0	8,50	14,7
260 100 00	100	2	30,6	30	5	15	3,0	14,0	18,5
260 120 00	120	2	36,6	36	5	15	3,0	21,0	23,7

* Basis of calculations see page 197.

** Up to a No. of Teeth of 30 the teeth run over the entire width of the gear.



Reworking within
24h-service possible.
Custom made parts
on request.