

V-Belt Pulleys Made from a Special Light Alloy with Cast-Iron core, 1 Groove

Bimetal V-belt pulleys similar to DIN 2211 or DIN 2217 matching narrow V-belts DIN 2215 und DIN 7753.

V-pelt pulleys with nominal diameters up to and including 250 mm are supplied as solid pulley, from 280 mm Ø as spoked pulley.

¹⁾ Can only be used with standard V-belt DIN 2215 .
* Without cast-iron core.

Ordering Details: e.g.: Product No. 150 102 00,
V-Belt Pulley Bi-metal, 1 Groove, 50/1/10

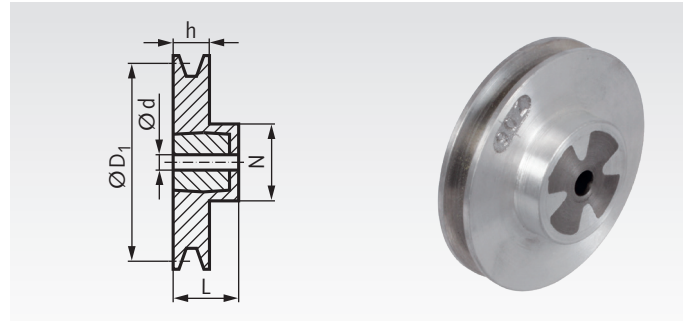

Profile XPZ, SPZ and Z (10) with 1 Groove

Product No.	Nominal Ø D ₁ mm	Pilot Hole d approx. mm	max. Bore mm	h mm	Hub Ø N approx. mm	Hub Length L approx. mm	Weight approx. kg
150 102 00	*50 ¹⁾	-	22	16	35	28	0,1
150 103 00	*56 ¹⁾	-	22	16	35	28	0,1
150 106 00	*63	-	22	16	35	28	0,1
150 107 00	*71	-	25	16	40	28	0,2
150 108 00	80	10	28	16	48	28	0,4
150 109 00	90	10	28	16	48	28	0,5
150 110 00	100	10	28	16	48	28	0,5
150 111 00	112	10	28	16	48	28	0,5
150 112 00	125	10	28	16	48	28	0,5
150 114 00	140	10	28	16	48	28	0,6
150 116 00	160	12	35	16	60	32	0,9
150 118 00	180	12	35	16	60	32	1,0
150 120 00	200	12	35	16	60	32	1,1
150 122 00	224	12	35	16	60	32	1,2
150 125 00	250	12	35	16	60	32	1,5
150 128 00	280	12	35	16	60	40	1,7
150 131 00	315	14	40	16	65	40	2,0

Profile XPA, SPA and A (13) with 1 Groove

Product No.	Nominal Ø D ₁ mm	Pilot Hole d approx. mm	max. Bore mm	h mm	Hub Ø N approx. mm	Hub Length L approx. mm	Weight approx. kg
152 102 00	*50 ¹⁾	-	22	20	35	28	0,1
152 103 00	*56 ¹⁾	-	22	20	35	28	0,15
152 106 00	*63	-	25	20	40	28	0,15
152 107 00	*71	-	25	20	40	28	0,2
152 108 00	80	10	28	20	48	28	0,4
152 109 00	90	10	28	20	48	28	0,5
152 110 00	100	10	28	20	48	28	0,5
152 111 00	112	10	28	20	48	28	0,5
152 112 00	125	10	35	20	60	32	0,7
152 114 00	140	10	35	20	60	32	0,8
152 116 00	160	12	35	20	60	40	1,0
152 118 00	180	12	40	20	65	40	1,3
152 120 00	200	12	40	20	65	40	1,4
152 122 00	224	12	40	20	65	40	1,5
152 125 00	250	12	45	20	75	50	2,2
152 128 00	280	12	45	20	75	50	2,4
152 131 00	315	12	45	20	75	50	2,8

V-Belt Pulleys GG in
Taper bushes-Type see
page 185.

Profile XPB, SPB and B (17) with 1 Groove

Product No.	Nominal Ø D ₁ mm	Pilot Hole d approx. mm	max. Bore mm	h mm	Hub Ø N approx. mm	Hub Length L approx. mm	Weight approx. kg
154 106 00	*63 ¹⁾	-	25	25	40	32	0,2
154 107 00	*71	-	25	25	40	32	0,25
154 108 00	80	10	35	25	60	32	0,5
154 109 00	90	10	35	25	60	32	0,6
154 110 00	100	12	35	25	60	32	0,7
154 111 00	112	12	35	25	60	32	0,7
154 112 00	125	12	35	25	60	32	0,8
154 114 00	140	12	35	25	60	32	0,9
154 116 00	160	12	35	25	60	40	1,1
154 118 00	180	12	40	25	65	40	1,4
154 120 00	200	12	40	25	65	40	1,5
154 122 00	224	12	40	25	65	45	1,9
154 125 00	250	12	45	25	75	45	2,3
154 128 00	280	14	45	25	75	45	2,4
154 131 00	315	20	45	25	75	45	2,7

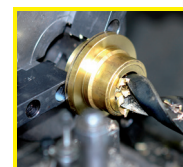

**Reworking within
24h-service possible.
Custom made parts
on request.**