

Chain Rider Sets for Single-Strand Roller

Material: Plastic POM-H. Screw zinc-plated steel.

To be mounted on the suitable tensioning element to create a ready-to-mount, cost-efficient chain tensioner. The shape of the rider, made from high-grade, friction resistant, industrial plastic, means the rider can be used on both rider sides and the large radius guarantees quiet operation. The maximum chain speed must not exceed 1.5 m/sec. Temperature range: -40° to +100°C.

Tensioning Element has to be ordered separately.

Ordering Details: e.g.: Product No. 140 851 00 Chain Rider Set 06 B-1

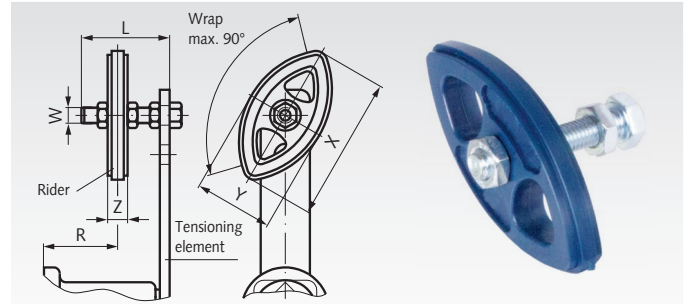

| Product No. | Suitable for Tensioning Element Size | DIN ISO | W mm | L mm | X mm | Y mm | Z mm | R _{min} mm | R _{max} mm | Weight kg |
|-------------|--------------------------------------|---------|------|------|------|------|------|---------------------|---------------------|-----------|
| 140 851 00 | 0 | 06 B-1 | M8 | 45 | 74 | 40 | 10,2 | 17 | 32 | 0,05 |
| 140 855 00 | 1 | 08 B-1 | M10 | 55 | 96 | 50 | 13,9 | 23 | 41 | 0,10 |
| 140 856 00 | 2 | 10 B-1 | M10 | 55 | 126 | 65 | 16,6 | 40 | 55 | 0,12 |
| 140 857 00 | 3 | 12 B-1 | M12 | 80 | 148 | 74 | 19,5 | 47 | 78 | 0,18 |

Chain Rider Sets for Double-Strand Roller

Material: Plastic POM-H. Screw zinc-plated steel.

To be mounted on the suitable tensioning element to create a ready-to-mount, cost-efficient chain tensioner. The shape of the rider, made from high-grade, friction resistant, industrial plastic, means the rider can be used on both rider sides and the large radius guarantees quiet operation. The maximum chain speed must not exceed 1.5 m/sec. Temperature range: -40° to +100°C.

Tensioning Element has to be ordered separately.

Ordering Details: e.g.: Product No. 140 851 00 Chain Rider Set 06 B-1

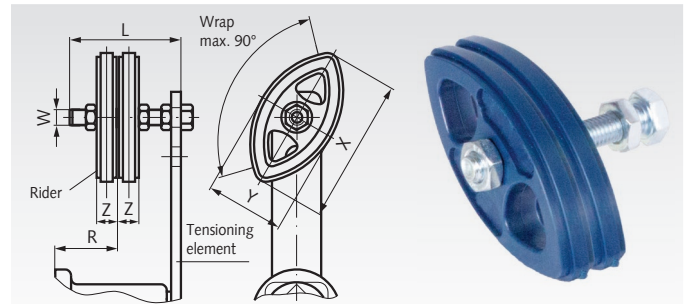

| Product No. | Suitable for Tensioning Element Size | DIN ISO | W mm | L mm | X mm | Y mm | Z mm | R _{min} mm | R _{max} mm | Weight kg |
|-------------|--------------------------------------|---------|------|------|------|------|------|---------------------|---------------------|-----------|
| 140 860 01 | 0 | 06 B-2 | M8 | 45 | 74 | 40 | 10,2 | 25 | 30 | 0,07 |
| 140 860 05 | 1 | 08 B-2 | M10 | 55 | 96 | 50 | 13,9 | 30 | 34 | 0,12 |
| 140 860 06 | 2 | 10 B-2 | M10 | 70 | 126 | 65 | 16,6 | 34 | 46 | 0,17 |
| 140 860 07 | 3 | 12 B-2 | M12 | 80 | 148 | 74 | 19,5 | 40 | 52 | 0,26 |



Lubricators page 854