

## Support for Tensioning Elements or Idlers

**Material:** Steel, blue painted.

This support enables an easy mounting of the tensioning element or an idler wheel to the machine. The hole A is for fastening the tensioner with its central screw. The mounting can be done at the front side or back side of the support. For any other purposes, the both holes B can be used to fix other parts instead of a tensioner.

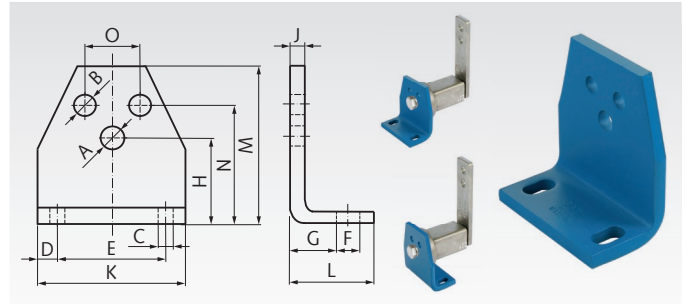

Ordering Details: e.g.: 140 800 01, Support for Tensioning Elements Size 0

Product No.	for Size	A mm	B mm	C mm	D mm	E mm	F mm	G mm	H mm	J mm	K mm	L mm	M mm	N mm	O mm	Weight kg
140 800 01	0	6,5	5,5	7	7,5	30	13	11,5	27	4	45	30	46	35	10	0,08
140 801 01	1	8,5	6,5	7	7,5	40	13	13,5	34	5	55	32	58	44	12	0,15
140 802 01	2	10,5	8,5	9,5	10	50	15,5	16,5	43	6	70	38	74	55	20	0,30
140 803 01	3	12,5	10,5	11,5	12,5	65	21,5	21,5	57	8	90	52	98	75	25	0,66
140 804 01	4	16,5	12,5	14	15	80	24	21	66	8	110	55	116	85	35	0,94
140 804 02	4	20,5	12,5	14	15	80	24	21	66	8	110	55	116	85	35	0,94

## Tensioning Elements in Standard Version

**Material:** Housing up to  $\varnothing 78$  mm made from sintered steel, over  $\varnothing 78$  mm made from grey cast iron, lever made from St52. Can be used for tensioning all common kinds of chain and belt drives. The elastomeric inserts are based on highly-elastic natural rubber with a good shape memory and are designed for applications in temperatures from  $-40^{\circ}$  to  $+80^{\circ}\text{C}$ .

The tensioning elements are painted blue and supplied with a zinc-plated screw and spring washer. Can be used for both tensioning directions. Temperature range:  $-40^{\circ}$  to  $+80^{\circ}\text{C}$ .

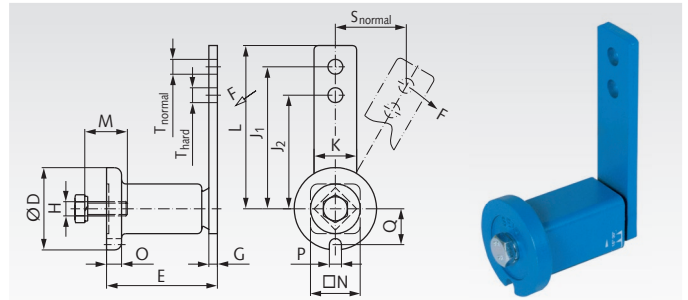

Ordering Details: e.g.: Product No. 140 800 00, Tensioning Element  $\varnothing 35$  mm

Product No.	Size	F max.		s max.		D mm	E mm	G mm	H mm	J <sub>1</sub> mm	J <sub>2</sub> mm	K mm	L mm	M mm	N mm	O mm	P mm	Q mm	T mm	M <sub>A</sub> Nm	Weight kg
		normal N	hard N	normal mm	hard mm																
140 800 00	0	96	128	40	30	35	51 <sup>+1,0</sup> <sub>-0,5</sub>	5	M6	80	60	20	90	20	22	6	8	16,5	8,5	10	0,18
140 801 00	1	135	170	50	40	45	64 <sup>+1,0</sup> <sub>-0,5</sub>	5	M8	100	80	25	112,5	25	30	8	8,5	20,8	10,5	25	0,37
140 802 00	2	350	440	50	40	58	79 <sup>+1,0</sup> <sub>-0,5</sub>	7	M10	100	80	30	115	30	35	10,5	8,5	25,3	10,5	49	0,66
140 802 12	2	350	440	50	40	58	79 <sup>+1,0</sup> <sub>-0,5</sub>	7	M10	100	80	30	115	30	35	10,5	8,5	25,3	12,5	49	0,65
140 802 16	2	350	440	50	40	58	79 <sup>+1,0</sup> <sub>-0,5</sub>	7	M10	100	80	30	115	30	35	10,5	8,5	25,3	16,5	49	0,64
140 803 00	3	810	1050	65	50	78	108 <sup>+2,0</sup> <sub>-0,5</sub>	8	M12	130	100	50	155	40	52	15	10,5	34,3	12,5	86	1,81
140 804 00	4	1500	1875	87,5	70	95	140 <sup>+2,0</sup> <sub>-0,5</sub>	10	M16	175	140	60	205	40	66	15	12,5	42	20,5	210	3,55

## Tensioning Elements, Zinc-Plated and Oil Resistant

**Material:** Casing made from sintered steel or grey cast iron, lever made from St52.

The design of these tensioning elements is identical to the standard version, but they are zinc-plated and the synthetic spring elements are resistant to mineral oils. These components are especially suited for "outdoor" applications, e.g. for construction machinery or for use inside the oilbath of a gearbox. The tensioning elements are marked with a yellow dot on the lever. Can be used for both tensioning directions.

Temperature range:  $-30^{\circ}$  to  $+90^{\circ}\text{C}$ .

Ordering Details: e.g.: Product No. 140 800 03, Tensioning Element  $\varnothing 35$  mm

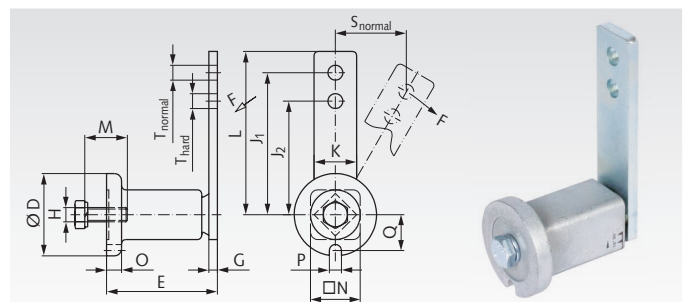

Product No.	Size	F max.		s max.		D mm	E mm	G mm	H mm	J <sub>1</sub> mm	J <sub>2</sub> mm	K mm	L mm	M mm	N mm	O mm	P mm	Q mm	T mm	M <sub>A</sub> Nm	Weight kg
		normal N	hard N	normal mm	hard mm																
140 800 03	0	96	128	40	30	35	51 <sup>+1,0</sup> <sub>-0,5</sub>	5	M6	80	60	20	90	20	22	6	8	16,5	8,5	10	0,2
140 801 03	1	135	170	50	40	45	64 <sup>+1,0</sup> <sub>-0,5</sub>	5	M8	100	80	25	112,5	25	30	8	8,5	20,8	10,5	49	0,6
140 802 03	2	350	440	50	40	58	79 <sup>+1,0</sup> <sub>-0,5</sub>	7	M10	100	80	30	115	30	35	10,5	8,5	25,3	10,5	49	0,6
140 803 03	3	810	1050	65	50	78	108 <sup>+2,0</sup> <sub>-0,5</sub>	8	M12	130	100	50	155	40	52	15	10,5	34,3	12,5	86	1,7
140 804 03	4	1500	1875	87,5	70	95	140 <sup>+2,0</sup> <sub>-0,5</sub>	10	M16	175	140	60	205	40	66	15	12,5	42	20,5	210	3,55