

Triple-Strand Sprockets DRS with Hub, ISO 10 B-3

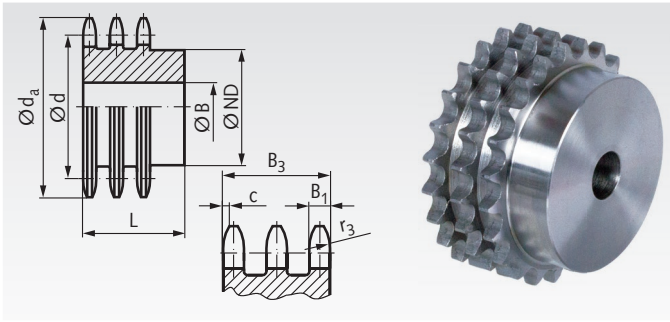

Material: Steel C45, not hardened.
Pre-bored.
Sprockets marked with * are made from grey cast iron GG25.

Ordering Details: e.g.: Product No. 136 108 00, DRS, ISO 10 B-3, 8 Teeth

ISO 10 B-3, Pitch 5/8 x 3/8"

$B_1 = 9 \text{ mm}$, $B_3 = 42.1 \text{ mm}$, $c = 1.6 \text{ mm}$, $r_3 = 16 \text{ mm}$

| Product No. | Number of teeth | d_a mm | d mm | ND mm | B mm | L mm | Weight kg |
|-------------|-----------------|----------|--------|-------|------|------|-----------|
| 136 108 00 | 8 | 48,4 | 41,48 | 25 | 12 | 55 | 0,27 |
| 136 110 00 | 10 | 58,3 | 51,37 | 35 | 16 | 55 | 0,47 |
| 136 111 00 | 11 | 63,2 | 56,34 | 39 | 16 | 55 | 0,61 |
| 136 112 00 | 12 | 68,2 | 61,34 | 44 | 16 | 55 | 0,78 |
| 136 113 00 | 13 | 73,2 | 66,32 | 49 | 16 | 55 | 0,96 |
| 136 114 00 | 14 | 78,2 | 71,34 | 54 | 16 | 55 | 1,15 |
| 136 115 00 | 15 | 83,2 | 76,36 | 59 | 16 | 55 | 1,37 |
| 136 116 00 | 16 | 88,3 | 81,37 | 64 | 16 | 60 | 1,72 |
| 136 117 00 | 17 | 93,3 | 86,39 | 69 | 16 | 60 | 1,99 |
| 136 118 00 | 18 | 98,3 | 91,42 | 74 | 16 | 60 | 2,27 |
| 136 119 00 | 19 | 103,3 | 96,45 | 79 | 16 | 60 | 2,58 |
| 136 120 00 | 20 | 108,4 | 101,49 | 84 | 16 | 60 | 2,91 |
| 136 121 00 | 21 | 113,4 | 106,52 | 85 | 20 | 60 | 3,12 |
| 136 122 00 | 22 | 118,4 | 111,55 | 90 | 20 | 60 | 3,48 |
| 136 123 00 | 23 | 123,5 | 116,58 | 95 | 20 | 60 | 3,86 |
| 136 124 00 | 24 | 128,5 | 121,62 | 100 | 20 | 60 | 4,25 |
| 136 125 00 | 25 | 133,6 | 126,66 | 105 | 20 | 60 | 4,67 |
| 136 127 00 | 27 | 143,6 | 136,75 | 110 | 20 | 60 | 5,43 |
| 136 130 00 | 30 | 158,8 | 151,87 | 120 | 20 | 60 | 6,65 |
| 136 138 00 | 38 | 199,1 | 192,24 | 120 | 25 | 60 | 10,08 |
| 136 145 00* | 45 | 236,0 | 227,58 | 100 | 32 | 60 | 7,04 |
| 136 157 00* | 57 | 296,6 | 288,18 | 100 | 32 | 63 | 8,00 |
| 136 176 00* | 76 | 392,5 | 384,16 | 110 | 35 | 67 | 12,00 |
| 136 183 00* | 95 | 488,5 | 480,14 | 125 | 35 | 70 | 19,40 |
| 136 188 00* | 114 | 584,5 | 576,13 | 125 | 35 | 80 | 24,00 |

Triple-Strand plate wheels DRL, ISO 10 B-3

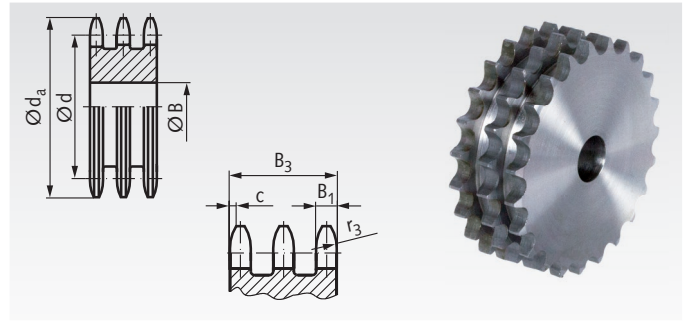

Material: Low-carbon steel, not hardable.
Pre-bored.

Ordering Details: e.g.: Product No. 136 208 00, DRL, ISO 10 B-3, 8 Teeth

ISO 10 B-3, Pitch 5/8 x 3/8"

$B_1 = 9 \text{ mm}$, $B_3 = 42.1 \text{ mm}$, $c = 1.6 \text{ mm}$, $r_3 = 16 \text{ mm}$

| Product No. | Number of teeth | d_a mm | d mm | B mm | Weight kg |
|-------------|-----------------|----------|--------|------|-----------|
| 136 208 00 | 8 | 48,4 | 41,48 | 12 | 0,23 |
| 136 212 00 | 12 | 68,2 | 61,34 | 12 | 0,67 |
| 136 213 00 | 13 | 73,2 | 66,32 | 12 | 0,81 |
| 136 214 00 | 14 | 78,2 | 71,34 | 12 | 0,97 |
| 136 215 00 | 15 | 83,2 | 76,36 | 12 | 1,14 |
| 136 216 00 | 16 | 88,3 | 81,37 | 16 | 1,29 |
| 136 217 00 | 17 | 93,3 | 86,39 | 16 | 1,49 |
| 136 218 00 | 18 | 98,3 | 91,42 | 16 | 1,70 |
| 136 219 00 | 19 | 103,3 | 96,45 | 16 | 1,92 |
| 136 220 00 | 20 | 108,4 | 101,49 | 16 | 2,15 |
| 136 221 00 | 21 | 113,4 | 106,52 | 16 | 2,40 |
| 136 222 00 | 22 | 118,4 | 111,55 | 16 | 2,66 |
| 136 223 00 | 23 | 123,5 | 116,58 | 16 | 2,94 |
| 136 224 00 | 24 | 128,5 | 121,62 | 16 | 3,23 |
| 136 225 00 | 25 | 133,6 | 126,66 | 16 | 3,53 |
| 136 227 00 | 27 | 143,6 | 136,75 | 20 | 4,13 |
| 136 228 00 | 28 | 148,7 | 141,78 | 20 | 4,47 |
| 136 229 00 | 29 | 153,7 | 146,83 | 20 | 4,83 |
| 136 230 00 | 30 | 158,8 | 151,87 | 20 | 5,20 |
| 136 235 00 | 35 | 184,0 | 177,10 | 20 | 7,23 |
| 136 238 00 | 38 | 199,1 | 192,24 | 25 | 8,55 |
| 136 245 00 | 45 | 236,0 | 227,58 | 25 | 12,24 |
| 136 257 00 | 57 | 296,6 | 288,18 | 25 | 20,06 |
| 136 276 00 | 76 | 392,5 | 384,16 | 30 | 36,27 |
| 136 283 00 | 95 | 488,5 | 480,14 | 30 | 57,32 |
| 136 288 00 | 114 | 584,5 | 576,13 | 30 | 83,15 |

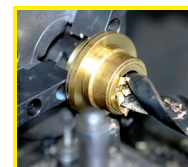

**Reworking within
24h-service possible.
Custom made parts
on request.**