

**Triple-Strand Sprockets DRS with Hub, ISO 06 B-3**

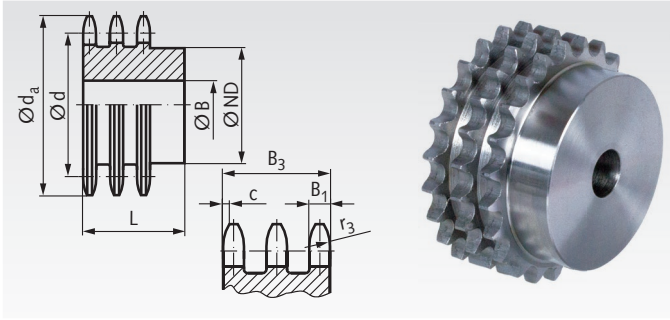

**Material:** Steel C45, not hardened.  
Pre-bored.  
Sprockets marked with \* are made from grey cast iron GG25.

Ordering Details: e.g.: Product No. 131 108 00, DRS, ISO 06 B-3, 8 Teeth

**ISO 06 B-3, Pitch 3/8 x 7/32"**

$B_1 = 5.2 \text{ mm}$ ,  $B_3 = 25.6 \text{ mm}$ ,  $c = 1.0 \text{ mm}$ ,  $r_3 = 10 \text{ mm}$

Product No.	Number of teeth	$d_a$ mm	d mm	ND mm	B mm	L mm	Weight kg
131 108 00	8	28,6	24,89	15	6	32	0,05
131 110 00	10	34,5	30,82	20	10	32	0,09
131 111 00	11	37,5	33,80	22	10	35	0,11
131 112 00	12	40,5	36,80	25	10	35	0,15
131 113 00	13	43,5	39,80	28	10	35	0,19
131 114 00	14	46,5	42,80	31	12	35	0,23
131 115 00	15	49,5	45,81	34	12	35	0,28
131 116 00	16	52,5	48,82	37	12	35	0,33
131 117 00	17	55,5	51,83	40	12	35	0,39
131 118 00	18	58,6	54,85	43	12	35	0,45
131 119 00	19	61,6	57,87	46	12	35	0,51
131 120 00	20	64,6	60,89	49	12	35	0,58
131 121 00	21	67,6	63,91	52	14	40	0,70
131 122 00	22	70,6	66,93	55	14	40	0,78
131 123 00	23	73,7	69,95	58	14	40	0,87
131 124 00	24	76,7	72,97	61	14	40	0,97
131 125 00	25	79,7	76,00	64	14	40	1,06
131 126 00	26	82,7	79,02	67	14	40	1,17
131 127 00	27	85,7	82,04	70	14	40	1,27
131 128 00	28	88,8	85,07	73	14	40	1,39
131 129 00	29	91,8	88,09	76	14	40	1,50
131 130 00	30	94,8	91,12	79	14	40	1,62
131 132 00	32	100,9	97,17	80	16	40	1,80
131 135 00	35	110,0	106,26	85	16	40	2,15
131 138 00	38	119,0	115,34	90	16	40	2,53
131 145 00*	45	141,1	136,54	90	23	56	3,56
131 157 00*	57	177,5	172,91	90	23	56	3,97
131 176 00*	76	235,1	230,49	100	23	56	4,52
131 183 00*	95	292,7	288,08	100	23	56	6,12
131 188 00*	114	350,3	345,68	100	23	56	7,45

**Triple-Strand plate wheels DRL, ISO 06 B-3**

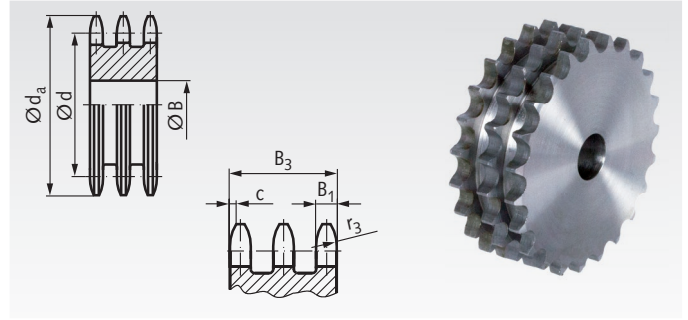

**Material:** Low-carbon steel, not hardable.  
Pre-bored.

Ordering Details: e.g.: Product No. 131 208 00, DRL, ISO 06 B-3, 8 Teeth

**ISO 06 B-3, Pitch 3/8 x 7/32"**

$B_1 = 5.2 \text{ mm}$ ,  $B_3 = 25.6 \text{ mm}$ ,  $c = 1.0 \text{ mm}$ ,  $r_3 = 10 \text{ mm}$

Product No.	Number of teeth	$d_a$ mm	d mm	B mm	Weight kg
131 208 00	8	28,6	24,89	6	0,04
131 211 00	11	37,5	33,80	10	0,09
131 212 00	12	40,5	36,80	10	0,12
131 213 00	13	43,5	39,80	10	0,15
131 214 00	14	46,5	42,80	12	0,18
131 215 00	15	49,5	45,81	12	0,22
131 216 00	16	52,5	48,82	12	0,26
131 217 00	17	55,5	51,83	12	0,30
131 218 00	18	58,6	54,85	12	0,35
131 219 00	19	61,6	57,87	12	0,39
131 220 00	20	64,6	60,89	12	0,44
131 221 00	21	67,6	63,91	14	0,48
131 222 00	22	70,6	66,93	14	0,54
131 223 00	23	73,7	69,95	14	0,59
131 224 00	24	76,7	72,97	14	0,66
131 225 00	25	79,7	76,00	14	0,72
131 226 00	26	82,7	79,02	14	0,79
131 227 00	27	85,7	82,04	14	0,86
131 228 00	28	88,8	85,07	14	0,93
131 229 00	29	91,8	88,09	14	1,01
131 230 00	30	94,8	91,12	14	1,09
131 238 00	38	119,0	115,34	16	1,81
131 240 00	40	125,1	121,40	16	2,02
131 242 00	42	132,1	127,46	16	2,25
131 245 00	45	141,1	136,54	16	2,61
131 248 00	48	150,2	145,64	16	2,99
131 257 00	57	177,5	172,91	20	4,28
131 276 00	76	235,1	230,49	25	7,83
131 283 00	95	292,7	288,08	25	12,42

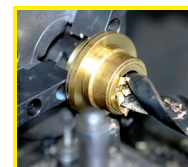

**Reworking within  
24h-service possible.  
Custom made parts  
on request.**