

## Triple-Strand Sprockets DRT for Taper Bushes

**Material:** Steel C45, not hardened or grey cast iron.

Sprockets for taper bushes, for easy and fast mounting.  
The taper bush has to be ordered separately, see page 390.

Product numbers ending with G are made from grey cast iron GG25.

Ordering Details: e.g.: Product No. 131 771 17, DRT, ISO 06 B-3, 17 Teeth,  
Dimension bore with Reference to Taper Bush Type, see page 390.

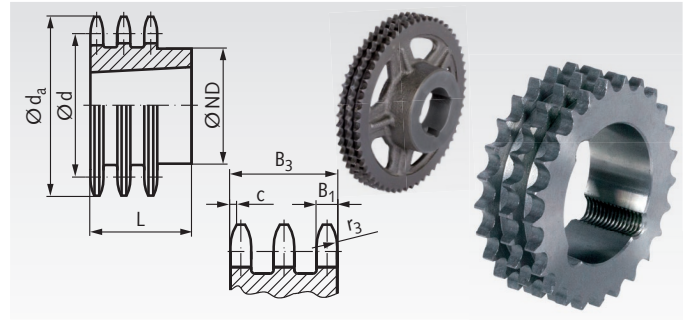

### ISO 06 B-3, Pitch 3/8 x 7/32"

$B_1 = 5.3$  mm,  $B_3 = 25.6$  mm,  $c = 1.0$  mm,  $r_3 = 10$  mm

Product No. DRT	Number of teeth	$d_a$ mm	$d$ mm	ND mm	L mm	Weight kg	Taper bush
131 771 17	17	55,3	51,83	-	25,6	0,15	1008
131 771 19	19	61,3	57,87	-	25,6	0,24	1008
131 771 21	21	68,0	63,91	-	25,6	0,34	1008
131 771 23	23	73,5	69,95	-	25,6	0,30	1210
131 771 25	25	80,0	76,00	-	25,6	0,41	1210
131 771 27	27	86,0	82,05	-	25,6	0,55	1210
131 771 30	30	94,7	91,12	79	38,0	0,88	1615
131 771 38	38	119,5	115,35	90	38,0	1,75	1615

### ISO 08 B-3, Pitch 1/2 x 5/16"

$B_1 = 7.2$  mm,  $B_3 = 34.9$  mm,  $c = 1.3$  mm,  $r_3 = 13$  mm

Product No. DRT	Number of teeth	$d_a$ mm	$d$ mm	ND mm	L mm	Weight kg	Taper bush
135 771 15	15	65,0	61,09	-	34,9	0,36	1008
135 771 17	17	73,6	69,11	-	34,9	0,35	1210
135 771 19	19	81,7	77,16	-	34,9	0,61	1210
135 771 21	21	89,7	85,22	-	34,9	0,65	1610
135 771 23	23	98,2	93,27	-	34,9	0,93	1610
135 771 25	25	105,8	101,33	-	34,9	0,85	2012
135 771 27	27	114,0	109,40	-	34,9	1,18	2012
135 771 30	30	126,1	121,50	-	34,9	1,73	2012
135 771 38	38	158,6	153,80	-	34,9	3,53	2012

### ISO 10 B-3, Pitch 5/8 x 3/8"

$B_1 = 9.1$  mm,  $B_3 = 42.1$  mm,  $c = 1.6$  mm,  $r_3 = 16$  mm

Product No. DRT	Number of teeth	$d_a$ mm	$d$ mm	ND mm	L mm	Weight kg	Taper bush
136 771 15	15	83,2	76,35	-	42,1	0,63	1210
136 771 17	17	93,3	86,39	-	42,1	1,01	1210
136 771 19	19	103,3	96,44	-	42,1	1,19	1615
136 771 21	21	113,4	106,51	-	42,1	1,66	1615
136 771 23	23	123,5	116,58	-	42,1	1,78	2012
136 771 25	25	133,6	126,66	105	45,0	1,81	2517
136 771 27	27	143,6	136,74	110	45,0	2,45	2517
136 771 30	30	158,8	151,87	120	45,0	3,54	2517

### ISO 12 B-3, Pitch 3/4 x 7/16"

$B_1 = 11.1$  mm,  $B_3 = 49.8$  mm,  $c = 2.0$  mm,  $r_3 = 19$  mm

Product No. DRT	Number of teeth	$d_a$ mm	$d$ mm	ND mm	L mm	Weight kg	Taper bush
137 771 15	15	99,8	91,62	-	49,8	1,11	1615
137 771 17	17	111,8	103,67	-	49,8	1,75	2012
137 771 19	19	123,9	115,73	-	49,8	2,02	2012
137 771 21	21	136,0	127,81	-	49,8	2,09	2517
137 771 23	23	148,1	139,90	-	49,8	3,00	2517
137 771 25	25	160,2	151,99	-	49,8	3,98	2517
137 771 27	27	172,3	164,09	140	51	3,90	3020
137 771 30	30	190,4	182,24	140	51	5,64	3020
137 771 38	38	239,0	230,69	140	51	11,58	3020
137 771 45	45	282,5	273,10	159	51	17,78	3020
137 771 45G	45	282,5	273,10	160	51	10,0	3020
137 771 57G	57	355,4	345,81	160	51	11,5	3020
137 771 76G	76	469,9	460,99	160	51	17,3	3020
137 771 83G	95	585,1	576,17	160	76	18,6	3030
137 771 88G	114	700,6	691,36	160	76	30,6	3030

### ISO 16 B-3, Pitch 1" x 17.02 mm

$B_1 = 16.2$  mm,  $B_3 = 79.6$  mm,  $c = 2.5$  mm,  $r_3 = 26$  mm

Product No. DRT	Number of teeth	$d_a$ mm	$d$ mm	ND mm	L mm	Weight kg	Taper bush
138 771 17	17	149,8	138,23	-	79,6	4,3	2517
138 771 19	19	165,9	154,31	-	79,6	4,4	3020
138 771 21	21	182,0	170,42	-	79,6	6,7	3030
138 771 23	23	198,1	186,53	-	79,6	7,8	3525
138 771 25	25	213,5	202,66	-	79,6	10,9	3525
138 771 27	27	230,4	218,79	-	79,6	14,1	3525
138 771 30	30	254,6	242,99	-	79,6	19,1	3525
138 771 38	38	320,7	307,59	-	79,6	34,0	3525
138 771 38G	38	320,7	307,59	178	89,0	19,9	3535
138 771 45G	45	377,1	364,13	216	102,0	30,0	4040
138 771 57G	57	474,0	461,07	216	102,0	38,0	4040
138 771 76G	76	627,0	614,65	216	102,0	53,3	4040
138 771 83	95	781,1	768,22	240	79,6	266,0	4030
138 771 83G	95	781,1	768,22	240	102,0	78,0	4040
138 771 88G	114	934,3	921,81	260	114,0	118,0	4545

### ISO 20 B-3, Pitch 1 1/4" x 3/4"

$B_1 = 18.5$  mm,  $B_3 = 91$  mm,  $c = 3.5$  mm,  $r_3 = 32$  mm

Product No. DRT	Number of teeth	$d_a$ mm	$d$ mm	ND mm	L mm	Weight kg	Taper bush
139 771 38G	38	399,6	384,49	178	89	35	3535
139 771 57G	57	591,5	576,36	216	102	62	4040
139 771 76G	76	783,5	768,32	240	102	79	4040

### ISO 24 B-3, Pitch 1 1/2" x 1"

$B_1 = 24.1$  mm,  $B_3 = 120.3$  mm,  $c = 4$  mm,  $r_3 = 38$  mm

Product No. DRT	Number of teeth	$d_a$ mm	$d$ mm	ND mm	L mm	Weight kg	Taper bush
139 775 38G	38	476,2	461,39	216	102	66	4040
139 775 45G	45	561,2	546,20	216	102	80	4040
139 775 57G	57	706,5	691,63	240	102	120	4040
139 775 76G	76	936,9	921,98	260	114	179	4545

Taper bushes page 340

